

# **Human Cryopreservation Procedures**

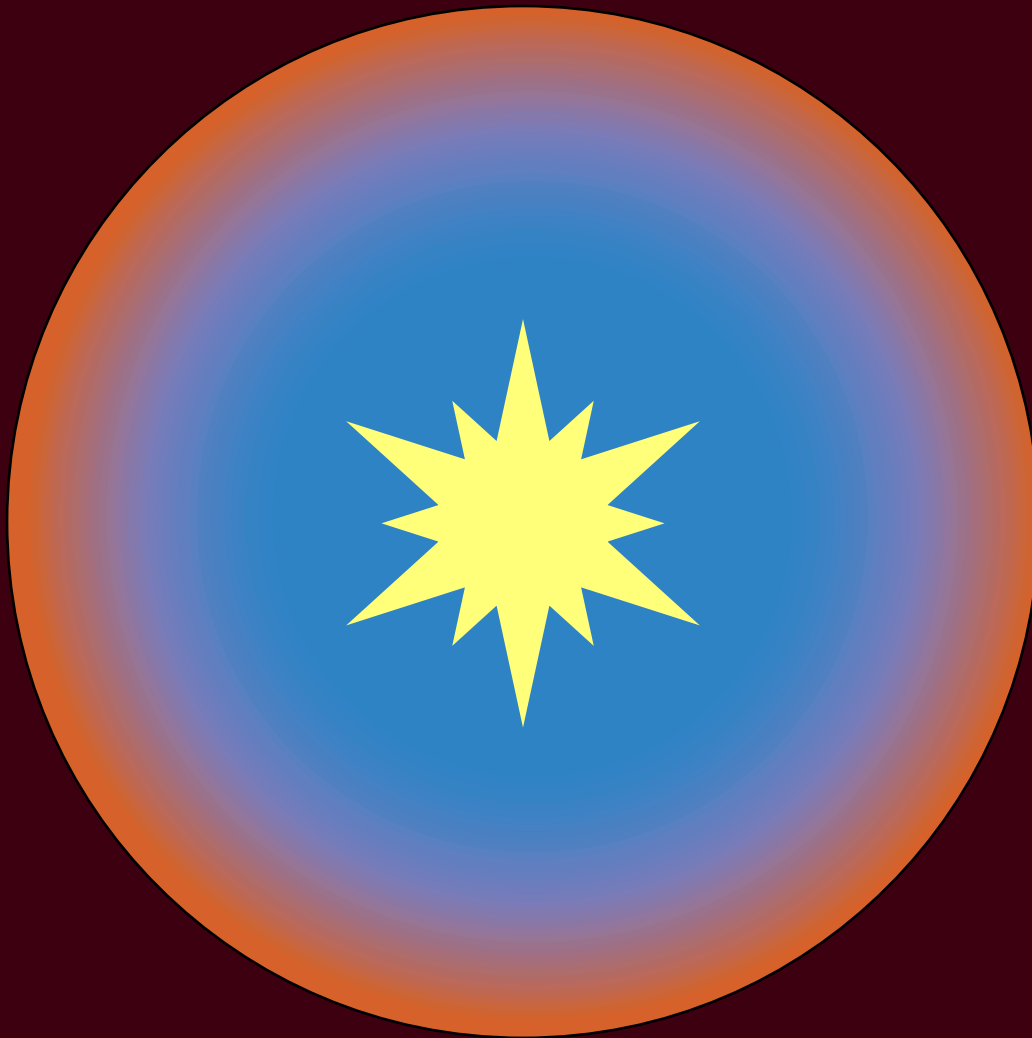

**Aschwin de Wolf  
Charles Platt**

# **Human Cryopreservation Procedures**

**By Aschwin de Wolf and Charles Platt**

## **Acknowledgments**

The authors and Alcor Life Extension Foundation wish to thank Saul Kent and Bill Faloon of the Life Extension Foundation, the Miller family of Canada, and Edward and Vivian Thorp as donors of the Miller/LEF/Thorp Readiness Grant to Alcor in 2008, which made this work possible.

For assistance in compiling and verifying information, we are especially grateful to Hugh Hixon, Steve Graber, and Mike Perry at Alcor. We received additional help from Steve Harris at Critical Care Research, and Steve Bridge, formerly of Alcor. Their willingness to donate time to this project was much appreciated.

## **How This Book Was Written**

Aschwin de Wolf wrote the first drafts of sections 2, 3, 5, 7, 8, 10, 13, 14, 15, 16, and 18. Charles Platt wrote the first drafts of sections 4, 6, 9, 11, 12, 17, 19, and 20. Each section was then reviewed and edited by the other collaborator. Additional information was provided by Steve Bridge. Finally, working on behalf of Alcor Life Extension Foundation, Brian Wowk fact-checked and edited all of the chapters. He should not be held responsible, however, for any errors that remain. They are our responsibility.

Information was gathered during several visits to Alcor Foundation where staff were very generous with their time. We appreciate their help.

Most of the original photographs were taken by Charles Platt, who also drew the diagrams.

# **Contents**

- 1. Introduction**
- 2. Theoretical Rationale for Cryonics Procedures**
- 3. Protocol**
- 4. Legal and Ethical Considerations**
- 5. Autopsy**
- 6. Deployment Issues**
- 7. Patient Assessment**
- 8. Health Issues and Communicable Diseases**
- 9. Cardiopulmonary Support: Circulation**
- 10. Cardiopulmonary Support: Ventilation**
- 11. Induction of Hypothermia**
- 12. Liquid Ventilation**
- 13. Medications**

**14. Monitoring**

**15. Sample Collection and Analysis**

**16. Remote Blood Washout**

**17. Patient Transport**

**18. Cryoprotection**

**19. Cooldown to Cryogenic Temperature**

**20. Long-Term Patient Care and Maintenance**

**Afterword by Charles Platt**

**Afterword by Aschwin de Wolf**

**Appendix 1: Quality of Patient Care in Cryonics**

**Appendix 2: Writing Case Reports**

# 1. Introduction

In this book we have tried to compile existing information describing standby, stabilization, transport, and vitrification procedures in the field of human cryopreservation, often referred to as cryonics.

This is a small field in which essential skills and knowledge reside in only a handful of people. Much of this information has not been recorded over the years, or has accumulated piecemeal in a variety of scattered sources. Many of these sources are now out of date.

Institutional amnesia has already caused some incremental losses. By making an accurate record of everything that we know now, we hope to safeguard the ability to perform cryonics procedures in the future.

In addition, we believe that for cryonics to gain credibility, eventually some uniform standards must be established. The first step in this direction is a summary of the current state of the art.

We have written this as a reference work rather than as a teaching manual. While we include some photographs and diagrams, and we describe how equipment should be deployed and used, we have not included quick-reference summaries or self-tests. We believe that the people who instruct students usually want to develop their own educational materials of this kind. Our task is to provide a reliable source from which teaching aids can be derived.

Since this work has been written for Alcor, it focuses primarily on procedures and equipment that are specific to Alcor. However, we have summarized approaches at Cryonics Institute and at Suspended Animation where we are able to do so.

The authors have collaborated productively on cryonics-related texts in the past. Generally, de Wolf has more theoretical knowledge and a stronger academic background, and has become professionally involved in relevant research. Platt offers practical experience derived from participating in 21 cryonics cases for Alcor, CryoCare, and Suspended Animation.

Inevitably, we have omitted some details. To take just one example, the knowledge of cryobiology necessary to achieve organ vitrification is far outside the scope of this book. Our goal is to provide a general, practical overview of the procedures currently being used in cryonics.

Individual chapters may be found online, where we hope that they will be updated from time to time. Eventually a print-on-demand version of the book will be available with procedures as they exist in 2019.

Aschwin de Wolf

Charles Platt



## **2. Theoretical Rationale for Cryonics Procedures**

### **Introduction**

Speculations about the ability to preserve human tissue of whole human bodies without deterioration to permit future resuscitation are almost as old as humanity itself. In an April 1773 letter to Jacques Barbeu Dubourg, a person no less than Founding Father of the United States of America Benjamin Franklin, wrote:

I wish it were possible . . . to invent a method of embalming drowned persons, in such a manner that they might be recalled to life at any period, however distant; for having a very ardent desire to see and observe the state of America a hundred years hence, I should prefer to an ordinary death, being immersed with a few friends in a cask of Madeira, until that time, then to be recalled to life by the solar warmth of my dear country! But . . . in all probability, we live in a century too little advanced, and too near the infancy of science, to see such an art brought in our time to its perfection.

During the 20th century a number of distinct developments gave rise to the contemporary practice of cryonics.

The most fundamental development that permitted meaningful practical discussion of the concept of human cryopreservation was the ability of physicists to achieve cryogenic temperatures and to maintain large volumes of matter at these temperatures. A predictable consequence of the ability to use low subzero temperatures in science was to study the properties of biological matter and microorganisms at such temperatures. These early efforts in low temperature biology gave rise to the science of cryobiology.

The modern era of cryonics followed soon after, when, in the early 1960s, cryonics pioneers Evan Cooper and Robert Ettinger recognized that the freezing damage that occurs when complex organs or whole mammals are cooled to cryogenic temperatures might not exclude meaningful repair and resuscitation, provided the original neuroanatomical basis of identity and memory could be deduced and reconstructed.

The technical feasibility of cryonics was further strengthened when investigations into the pathophysiology of cerebral ischemia showed that loss of cerebral viability does not produce instantaneous ultrastructural decomposition of the brain.

During the last two decades ongoing progress in organ vitrification (solidification without ice formation) and the ability to manipulate and alter human biochemistry at progressively smaller scales have tended to validate the vision of the early cryonics pioneers that cryogenic temperatures might be employed to allow a second diagnosis of the patient by a future physician at a time when more advanced treatments may be available.

## **The Evolution of Death**

One of the distinguishing features of contemporary medical practice is the growing recognition that death is not an event, but a process. As a consequence, it has become increasingly routine to distinguish between legal, medical and biological definitions of death, and more rigorous distinctions are being proposed as our knowledge progresses.

The first step in coming to grips with the phenomenon of death was made when scientists could attribute death to the cessation of specific physiological functions instead of some mysterious force. The next discovery that jumpstarted the science and practice of cardiopulmonary resuscitation was the observation that death is a reversible process, provided that circulation and respiration are artificially maintained while efforts are made to promptly restore circulation. During the 20th century the development of cardiopulmonary bypass allowed man-made devices to control circulation and respiration completely and safely to permit advanced surgical procedures on the heart and the brain.

It was only a matter of time before scientists gradually severed the link between metabolism and life completely. The simple observation that some life forms periodically enter and recover from states of reduced metabolism gave rise to the broader study of depressed metabolism. For example, the extremophile tardigrade (also known as the water bear) can tolerate complete arrest of its normal metabolism. The limiting factor for complete metabolic arrest is not the continued presence of a “vital spark” but an evolved or engineered physiology that can tolerate the conditions that produce metabolic arrest.

During the second half of the 20th century, the practice of general anesthesia and hypothermic circulatory arrest in medicine further corroborated the view that life, metabolism, consciousness, and personal identity can be approached from a unified physicalist perspective. In particular, the practice of therapeutic hypothermic circulatory arrest is of great relevance to the practice of cryonics because it demonstrates that humans can be cooled to profound hypothermic temperatures (as low as +18 degrees C) with stoppage of brain electrical activity, and can be recovered with no adverse neurological consequences. What distinguishes cryonics from these procedures is that the patient’s temperature may be lowered just below the glass transition temperature of a perfused vitrification solution to induce complete metabolic arrest, and long-term preservation may be at –196 degrees C, in liquid nitrogen.

As is well known to practicing cryobiologists, complex organized life forms such as humans cannot be lowered to liquid nitrogen temperature without producing substantial freezing damage. To advocates of human cryopreservation this is not necessarily a contraindication for cryopreservation as long as the brain of the person is stabilized in a state that permits reconstruction of the original neuroanatomical state that gives rise to the unique identity and memories of the person. If the original anatomical state of the brain and viability can be restored, the patient can be recovered, similar to patients recovering from hypothermic circulatory arrest.

In his paper “Molecular Repair of the Brain” by Ralph Merkle, first published in the October 1989 *Cryonics* magazine and currently accessible on

the web site at [www.alcor.org](http://www.alcor.org), Merkle proposed an *information-theoretic* criterion of death:

A person is dead according to the information-theoretic criterion if their memories, personality, hopes, dreams, etc. have been destroyed in the information-theoretic sense. That is, if the structures in the brain that encode memory and personality have been so disrupted that it is no longer possible in principle to restore them to an appropriate functional state, then the person is dead. If the structures that encode memory and personality are sufficiently intact that inference of the memory and personality are feasible in principle, and therefore restoration to an appropriate functional state is likewise feasible in principle, then the person is not dead.

The information-theoretic definition of death is not just a rationalization of the cryonics practice but reflects the mainstream view of physics and (bio) chemistry that the function and properties of a substance are defined by the specific organization of its molecules and extends this perspective to the concept of personhood. The criterion also arises in the context of diagnosing brain death or alternatives for cryonics such as chemical brain preservation.

The information-theoretic definition of death is highly relevant to the ethics of performing human cryopreservation under diverse biological conditions, some of which may seem quite poor. However, as we shall discuss below, recent experimental evidence in neural cryobiology supports the position that cryonics as an elective medical procedure may also be able to withstand more conventional medical criteria for diagnosing death.

## **From Freezing to Vitrification**

From its original inception, the objective of cryopreservation technologies in cryonics has been to reduce cellular and ultrastructural injury associated with ice formation. This research program culminated in 2000 with the introduction of the use of vitrification solutions at the Alcor Life Extension Foundation.

Ice formation during cryopreservation presents a challenge for human cryopreservation. Because of ice formation the patient will not just require treatment of his terminal illness and rejuvenation, but extensive repairs to cells

and organized tissue due to ice crystal damage. Since the inception of cryonics, freezing without cryoprotectant chemicals (so called “straight freezing”) has not been rejected as a procedure from which recovery is impossible, but there has been a consensus that the less damage that is done during the cryopreservation process, the better.

As a consequence, there has been a great interest in the use of cryoprotectants and the complete elimination of ice formation through vitrification. The idea of vitrification was discussed by notable early cryobiology pioneers such as Basile J. Luyet, but it was not until the focused research of cryobiologist Gregory M. Fahy and his colleagues in the 1980s and 1990s that the objective of solidification without ice formation was systematically explored for the cryopreservation of organs.

One of the major misconceptions about vitrification is that this approach requires extremely rapid cooling rates. It is correct that vitrification of pure water requires small samples to be cooled at rates approaching 1,000,000 degrees Celsius per minute, but these requirements are greatly relaxed in the presence of high concentrations of a suitable cryoprotectant.

As a matter of fact, the actual challenge in cryobiology is not to design solutions that resist ice formation at slow cooling rates but to design vitrification solutions with no toxicity. Since the early days of vitrification research the aim of Dr. Fahy and his colleagues has been to discover the mechanisms that rule cryoprotectant toxicity and to design vitrification solutions to mitigate those factors. In 2005 this research culminated in the vitrification (to -135 degrees Celsius), rewarming, and transplantation of a rabbit kidney with good viability and functionality using the proprietary vitrification solution M22. M22 takes advantage of the following vitrification solution design discoveries:

1. High concentrations of a cryoprotective agent (or a mixture of different cryoprotective agents) can prevent ice formation during cooldown and warming.
2. The toxicity of some cryoprotectants can be significantly reduced by combining them with other cryoprotective agents.

3. The general toxicity of a vitrification agent can be predicted by using a measure called  $qv^*$ , allowing for the rational formulation of less toxic vitrification agents.
4. Within limits, non-penetrating agents can reduce the exposure of cells to toxic amounts of cryoprotectants without reducing vitrification ability.
5. Synthetic “ice blockers” can be included in a vitrification mixture to inhibit the formation of ice, thus enabling a lower concentration of other toxic cryoprotective agents necessary to achieve vitrification.
6. Substituting methoxyl (-OCH<sub>3</sub>) for hydroxyl groups (-OH) in conventional cryoprotective agents can decrease viscosity, increase permeability, and reduce the critical cooling rate necessary to avoid ice formation.
7. Chilling injury can be eliminated by introducing the vitrification agent with a hypertonic concentration of non-penetrating solutes.
8. In cryonics, with a minor proprietary modification, M22 can be used in whole body perfusion without causing severe edema that has been a problem for some other solutions.

It goes beyond the scope of this text to fully discuss the technical details of each of these discoveries in detail but a number of these breakthroughs are worth mentioning.

Perhaps the most important conceptual breakthrough for formulating vitrification solutions with low toxicity and strong resistance against ice formation was the discovery that high concentrations of (penetrating) cryoprotective agents do not necessarily increase toxicity. Contrary to conventional cryobiology expectations, Fahy et al., found that weaker glass formers favor higher viability. They proposed a new compositional variable called  $qv^*$  to predict the general toxicity of vitrification solutions. Using  $qv^*$  they made the counterintuitive decision to substitute a higher concentration of the weaker glass former ethylene glycol for propylene glycol to create a

solution called Veg, which produced a substantial increase in cellular viability over older vitrification solutions. A proposed explanation for this phenomenon is that vitrification solutions containing permeating cryoprotectants with a higher  $qv^*$  leave less water available for hydrating biomolecules, compromising intracellular viability.

Another important breakthrough was the discovery of synthetic “ice blockers.” Naturally occurring antifreeze proteins that inhibit heterogeneous nucleation have been suggested to assist in vitrification of complex biological systems. Limited supply, and the costs of such anti-freeze proteins, have been major obstacles in using them for organ preservation; but in 2000, Brian Wowk et al proposed that the property of selective binding to heterogeneous nucleators could also be achieved by using synthetic polymers. It was found that a copolymer consisting of 80% w/w low molecular weight polyvinyl alcohol (PVA) and 20% vinyl acetate substantially reduced ice formation when added to standard cryoprotectants. This copolymer is now being sold as Supercool X-1000 by the cryobiology company 21st Century Medicine.

Another polymer, polyglycerol (PGL), was found to selectively inhibit bacterial ice nucleation and complement the more general action of PVA in inhibiting ice nucleation. This polymer is currently being sold as Supercool Z-1000, and the combination of the two enables inhibition of ice formation that is superior to either of the two polymers alone. By lowering the minimum concentration of cryoprotectant(s) needed to vitrify, and thus lowering the total viscosity of the solution, the addition of X-1000 and Z-1000 represented another step towards reversible organ vitrification.

It has been long understood that absent ice formation and toxicity there are other forms of injury associated with cooling to low temperatures. One of the distinguishing features of M22 is that it is introduced to organs in a hypertonic concentration of non-penetrating solutes to eliminate this so called “chilling injury.”

The remaining challenges in perfecting vitrification for whole organs include further reductions of cryoprotectant toxicity and refining cryoprotectant perfusion and unloading protocols to achieve complete equilibration of the vitrification solution to permit long term storage at cryogenic temperatures and successful recovery. In principle, there is little

difference between the state of the art in today's cryobiology research and the technologies that are utilized in human cryopreservation. As we shall see later, the practice to improve cryonics procedures has been one of the key drivers of contemporary vitrification research.

## Neural Cryobiology

There has been relatively little interest in cryopreservation of the whole brain. Notable exceptions include the feline brain cryopreservation studies by Isamu Suda in the 1960s and more systematic neural cryobiology studies by Gregory M. Fahy in the early 1980s. Robert J. White has discussed the prospects of brain cryopreservation but in his own published work confined himself to whole brain hypothermic preservation. Of related interest are the whole-body high subzero resuscitation experiments of rats and hamsters that were conducted by Audrey Smith, Radoslav Andjus, and James Lovelock.

Two major reasons why neural cryobiology has so remained a relatively ignored part of cryobiology is that practicing researchers fear being associated with cryonics and the controversy surrounding other applications of neural cryobiology such as whole brain transplants.

A good historical and scientific overview of neural cryobiology up until 1988 is available in the article "The Cryobiological Case for Cryonics" that was published in the March 1988 issue of *Cryonics* magazine. This article presented evidence that even the relatively crude cryopreservation techniques of the 1980s could provide robust ultrastructural protection of the brain.

Also, the high-subzero rat and hamster resuscitation studies of Audrey Smith and Radoslav Andjus corroborate the premise of cryonics that brains can be cooled to subzero temperatures and restored to functionality. However, in the chapter "Problems of Resuscitating Larger Animals" in her seminal book *Biological Effects of Cooling and Supercooling*, Audrey Smith wrote:

So far no technique has been evolved for perfusing individual organs or the whole mammal with glycerol and removing it without damage. If this could be done it might be possible to cool the intact mammal to and resuscitate it from temperatures as low as -70 degrees Celsius. Long term storage of frozen



mammals might be considered. It must be emphasized that there is no prospect of accomplishing this in the near future.

Since Smith wrote these words, substantial progress has been made in the cryopreservation of complex organs and toward the perfection of loading and unloading the brain with cryoprotective agents. In particular, the development of low toxicity vitrification solutions has greatly reduced the challenges associated with ice formation that were encountered in past whole body and brain cryopreservation research.

In the late 1990s an ambitious research program was launched to investigate and validate the use of the new generation of vitrification solutions in rat hippocampal slices. In these experiments the investigators were able to recover hippocampal brain slices from -130 degrees Celsius without loss of viability and with excellent ultrastructural preservation. The most successful results were obtained using a high molar vitrification solution called VM-3 that incorporates a carrier solution aimed at mitigating chilling injury and two proprietary ice blockers to inhibit ice formation. In 2007, an announcement was made at the Suspended Animation conference that more sophisticated vitrification solutions incorporating the same principles and new insights were successful in demonstrating maintenance of the ability to exhibit Long Term Potentiation (LTP) in rabbit brain slices after cooling below the glass transition temperature of the vitrification solution and rewarming.

The most logical step in neural cryobiology is to seek consistent reversal of whole brain electrical activity after cryopreservation. The only published precedents for this kind of research are the experiments conducted by Isamu Suda et al. In two papers, published in *Nature* (1966) and *Brain Research* (1974), Suda reported that he measured organized electrical activity in cat brains that were rewarmed after being preserved at -20 degrees Celsius for respectively 45-203 days and 7 years (!). He used cryoprotection with 15% v/v glycerol after storage. As encouraging as these results are, the fact that they appear to be at odds with what can be expected from other organs subjected to such cryopreservation regimes is peculiar.

Research aimed at vitrification of complex mammalian organs, and the practice of cryonics, have contributed to a much improved understanding of

the requirements for successful introduction and removal of vitrification solutions from the whole brain. In particular, the use of software-controlled perfusion allows for a gradual equilibration of the vitrification agent in the brain under precise temperature control to mitigate osmotic injury and cryoprotectant toxicity. As can be seen in Figure 2-1, courtesy of 21st Century Medicine, vitrification can confer good ultrastructural preservation to the mammalian brain.



*Figure 2-1. Suprahippocampal white matter after perfusion with M22 for 60 minutes at  $-3$  degrees C, cooling to below the glass transition temperature, rewarming, and perfusion fixation.*

As the coming decades may witness reports of whole brains being cooled and recovered from below the glass transition temperature without loss of electrical activity, the topic of legal protection of cryonics patients will force itself to the center of bioethical debates about cryonics.

## **Cell Repair Technologies**

The ability to repair cells at the molecular level will almost certainly be necessary before revival of cryonics cases can take place, at least for those who are preserved within the capability of current cryoprotectants. There are four potential targets for cell repair:

1. Treatment of the disease or insult that prompted the cryopreservation of the patient.
2. Repair of ischemic injury resulting from delays between pronouncement of legal death and the start of cryonics stabilization procedures.
3. Repair of damage incurred during the cryopreservation process itself.
4. Reversal of the aging process and associated co-morbidities.

One of the most prevalent misconceptions about cryonics is that its technical feasibility is exclusively wedded to a particular conception of cell repair technologies. While it is correct that advocates and researchers of molecular nanotechnology (MNT) have generally been supportive of cryonics, mechanosynthesis technologies by no means exhaust the options for cell repair. As a matter of fact, there has been an ongoing debate within cryonics about the feasibility and advantages of alternative approaches since its inception.

The biological approach to cell repair starts with the observation that evolution itself demonstrates the technical feasibility of manipulation of matter at the molecular level. The objective of bio-nanotechnology then is to harness, modify, and guide biomolecules to accomplish new tasks. One of the earliest biological proposals to resuscitation of cryonics patients involved using modified viruses to achieve comprehensive cell repair. Another proposal has been to use modified white blood cells to perform reversal of damage. One underappreciated fact about the role of biotechnology is that it can also be utilized prior to the cryopreservation process with the aim of making cells and tissue more tolerant to the cryopreservation process.

An alternative paradigm for cell repair is to use mechanosynthesis, by which molecules are directed towards desired configurations through the use of mechanical means, as opposed to chemosynthesis which involves the interaction of molecules through random motion in an aqueous medium. The most rudimentary proof of concept of mechanically-directed positioning of atoms was achieved in 1988 when researchers at IBM's Zurich Research Institute successfully spelled the letters "IBM" in xenon atoms on a cryogenic copper surface. In 2000 Robert Freitas and Ralph Merkle founded the Nanofactory Collaboration, an effort of researchers associated with various organizations to initiate a focused experimental agenda towards positionally-controlled diamond mechanosynthesis and diamondoid nanofactory development.

The requirements of such envisioned repair technologies in cryonics are a function of the degree of damage that needs to be addressed. For example, for some cryonics patients a combination of protein renaturation, organ replacement and gene therapy may suffice to restore the patient to good health. For cryonics patients with extensive ischemic and cryopreservation damage, cell repair technologies as envisioned by mechanosynthesis researchers will be required.

## **Rejuvenation**

Interventions aimed at rejuvenation will be required in most cryonics patients to prevent the patient succumbing to another age-related disease shortly after revival. For a small subset of cryonics patients, halting or slowing the aging process might be sufficient, but it is reasonable to assume that many patients would also prefer to bring their biological age to a level of their own choice.

There are broadly two modes of thought about rejuvenation in cryonics. One perspective argues that technologies that are powerful enough to repair cell damage at the molecular level will also be powerful enough to control and reverse the aging process. In this scenario, control of aging and morbidity will be one of the medical applications of molecular nanotechnology. This reasoning has also played an important role in the decision of some cryonics advocates to elect neuropreservation under the assumption that molecular

technologies that permit repair of the brain can also grow a new body. Ultimately, a very mature nanotechnology could be used to induce warm biostasis, which would bring all the elements of the cryonics program under the nanotechnology rubric.

Not all advocates of cryonics are persuaded by such appeals to the power of mature nanotechnology. They advocate separate research into interventive biogerontology and rejuvenation. Absent the perfection of nanomedicine, achieving control over the human aging process will provide additional corroboration for the cryonics program. A separate argument for such research is that if the aging process can be slowed or reversed in humans, the need to cryopreserve people who are afflicted with age-associated illnesses will be reduced. As a consequence, the practice of human cryopreservation would be confined to diseases and insults that are resistant to control over the aging process.

The most ambitious and well-publicized research program that aims to use regenerative medical procedures to defeat aging is SENS (Strategies for Negligible Senescence). The SENS approach, as advocated by Aubrey de Grey and his colleagues, distinguishes itself from most conventional biogerontology research by emphasizing a results-driven approach to repair age-associated damage as opposed to conducting research to elucidate the mechanisms that drive the aging process. The advantage of aiming at actual rejuvenation is that the efficacy of interventions can be assessed in a relatively short time-span, as opposed to interventions that aim to slow down the aging process or extend the maximum life span.

The SENS program identifies the following biological manifestations of aging for clinical intervention:

1. Cell loss and tissue atrophy.
2. Oncogenic nuclear mutations and epimutations.
3. Cell senescence (death resistant cells).
4. Mitochondrial mutation.
5. Intracellular aggregates.

6. Extracellular aggregates.

7. Random extracellular cross-linking (tissue stiffening).

The SENS program has been criticized along two lines, which I will call “external” and “internal” criticisms. At the most general level, SENS, and its most prominent advocate Aubrey de Grey, has been charged with raising expectations that this program can succeed in the absence of experimental results, within an optimistic projected timeline. Essentially, since all the research objectives of SENS are falsifiable in principle, this debate concerns not so much the technical credibility of the project as the question of how researchers should communicate their objectives and projected achievements.

Internal criticisms are concerned with the internal coherency of the SENS program and its technical details. Cryonics advocate Benjamin Best has argued that two of the seven strategies of the SENS program, making copies of mitochondrial DNA in the nucleus (and importing the resulting proteins back into the mitochondria) and deletion of genes that contribute to cancer, should not be considered “repair” but strategies to prevent aging. A more fundamental objection he raises is that SENS ignores the role of nuclear DNA damage as a cause of (brain) aging. Other objections question whether SENS is actually the most results-oriented approach considering the possibility that the aging program is controlled by a finite number of upstream genes that are susceptible to modification. A more conceptual criticism is that, in practice, the difference between the traditional biogerontology approach and the engineering approach that SENS advocates is a matter of degree, not principle. Interventions that aim to restore an organism to a youthful state allow for short-term validation but longer term adverse consequences cannot be ruled out. As such, the practical implementation of the SENS approach may require substantial modifications in how society thinks about patient autonomy and regulating new therapies.

## **Historical Development of Cryonics Procedures**

From the moment of its original conception, the practice of cryonics has relied upon past and future progress in the science and practices of mainstream

cryobiology and medicine. The commonly held view of cryonics as the practice of freezing humans without any form of cryoprotection has not been endorsed by any of the major cryonics providers. Cryopreservation without protection against ice formation (a so called “straight freeze”) is only practiced in cases where extensive ischemia prevents cryoprotectant perfusion. Even before the first attempted cryopreservation of a human, the biophysicist Dr. Dante Brunol had outlined a protocol that incorporated the use of cardiopulmonary support after legal pronouncement of death, extracorporeal perfusion, and the use of cryoprotective agents.

During the late 1970s and early 1980s myocardial recovery researcher Jerry Leaf and kidney dialysis technician and cryonics researcher Michael Darwin introduced contemporary extracorporeal bypass techniques and equipment to the practice of cryonics. Extracorporeal circulation is used during cryoprotectant perfusion of the patient and, in remote cases, a portable perfusion unit may be used to replace the blood of the patient with an organ preservation solution. In the mid-1980s the Alcor Life Extension Foundation formulated a whole-body blood substitute called MHP, a high potassium “intracellular” solution that incorporates hydroxyethyl starch, mannitol, HEPES and a number of components to protect against free radical damage and support metabolism during the hypothermic (above 0 degrees C) phase of cryonics.

During the early years of cryonics DMSO was routinely used as the cryoprotective agent of choice, but this practice was progressively abandoned in favor of glycerol because DMSO was observed to increase edema during the cryoprotective perfusion of whole-body patients. Ultrastructural studies of brains perfused with glycerol indicated that patients could benefit from higher concentrations of glycerol. Unlike DMSO, in a suitable carrier solution (such as MHP) glycerol can be used as a mono-agent at high concentrations. In the 1990s the target concentration for glycerol perfusion at the Alcor Life Extension Foundation was increased to ~7.5M until this agent was eventually replaced by the new generation of vitrification solutions.

One other important consequence of the introduction of extracorporeal perfusion technologies is that it allowed for introducing the cryoprotectant in a controlled, linear fashion to avoid osmotic shock. Such ramped cryoprotectant

perfusion requires the addition of a recirculating reservoir to the perfusion circuit. A typical ramped cryoprotectant perfusion starts with the perfusion of the carrier solution or low concentration of the cryoprotectant agent in carrier solution and gradually pumps the high concentration solution to the recirculating reservoir where it is mixed with the carrier solution and introduced to the patient. Inline and manual refractometry measurements are taken to monitor and control the progressive increase of the cryoprotective agent. Cryoprotectant perfusion is complete when the refractometry readings of the venous effluent indicate that equilibration of the tissues at the target concentration has been achieved.

In 2000 the Alcor Life Extension Foundation replaced glycerol with the vitrification agent B1C for neuropatients. To reduce viscosity, B1C was quickly followed by the nearly-identical solution B2C, a hyper-stable multi-component vitrification agent that incorporates many recent discoveries in cryobiology, such as the use of high concentrations of weak glass-formers and the addition of ice blockers to increase resistance against ice formation with reduced toxicity. B2C was introduced in a carrier solution that is optimized for inhibiting chilling injury and for enhanced performance of the ice blockers.

In 2005, B2C was replaced by M22, the least toxic vitrification solution usable at high concentrations in the cryobiology peer reviewed literature to date. In addition to the discoveries embodied in B2C, M22 incorporates the use of methoxylated cryoprotectants to further reduce toxicity and to improve equilibration. An alternative formulation of M22 is available for whole body patients that permits the use of this agent without increasing edema during cryoprotective perfusion. Initial perfusion of M22 is conducted ~0 degrees C and the temperature is further dropped to ~ -3 degrees C when 50% of target concentration has been reached.

After cryoprotectant perfusion the patient is gradually cooled to liquid nitrogen temperature. Older cooling protocols used a combination of dry ice and silicone oil to cool the patient (Alcor) or the gradual lowering of the patient into the dewar to minimize thermal stress and fracturing.



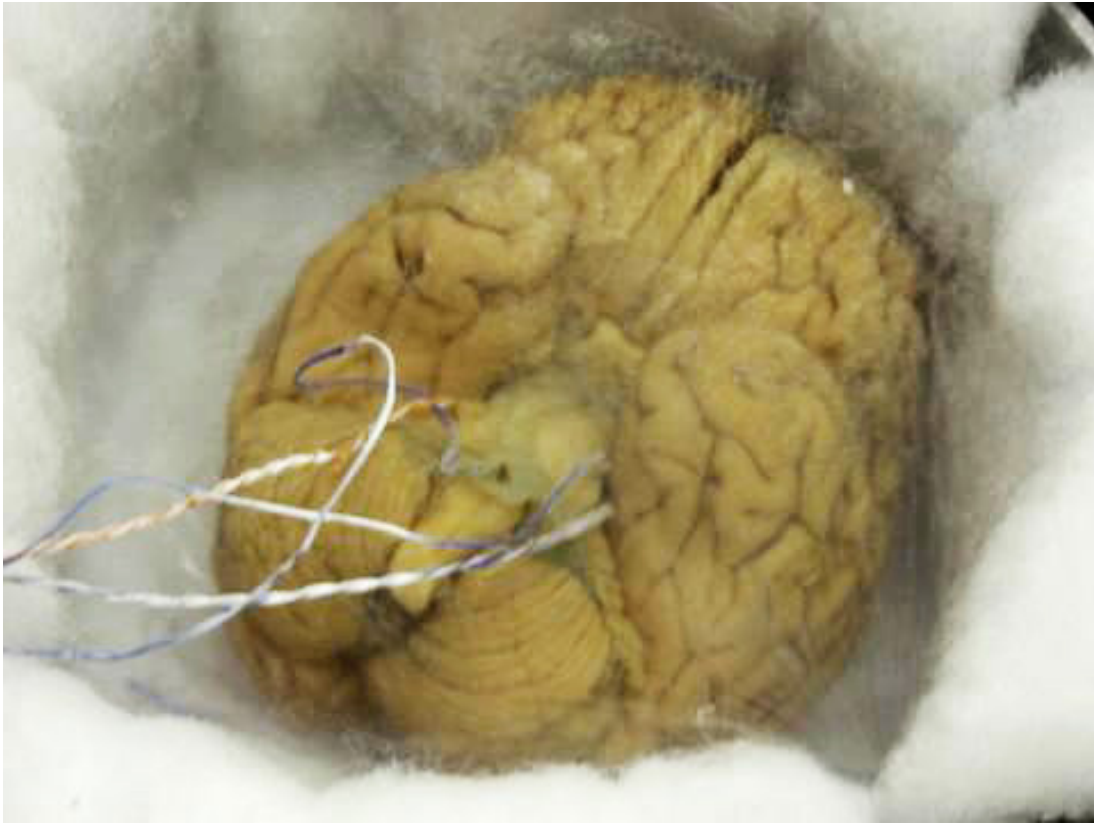

*Figure 2-2. Vitrified human brain of Alcor patient A-2077 under liquid nitrogen.*

Since the mid-2000s both major cryonics organizations have used a computer-controlled cooling box that injects liquid nitrogen vapor to cool the patient down to liquid nitrogen temperature. The protocol for patients who have been perfused with a vitrification solution is to lower the temperature as fast as possible to near the glass transition temperature of the vitrification solution and then to slowly lower the temperature over days to minimize fracturing. Patients are either maintained in a hard vacuum dewar (Alcor) or a soft vacuum cryostat (Cryonics Institute) for long term care.

Effective cryopreservation requires prompt intervention after cardiac arrest and pronouncement of legal death. To achieve this, Alcor attempts to arrange a “standby” for a member when there is advance notice or high risk of legal death. During standby a team of staff members and medical professionals is deployed to the location of the terminal patient to minimize

the delay between legal pronouncement of death and the start of cryonics stabilization procedures.

The objective of cryonics stabilization procedures is to maintain viability of the brain by contemporary medical criteria. Modern stabilization technologies consist of three distinct procedures:

1. Cardiopulmonary support to restore circulation and respiration, circulate medications and enhance external cooling.
2. Induction of hypothermia to depress metabolism and protect the brain.
3. Administration of medications to depress metabolism, increase cerebral blood flow, prevent and reverse blood clotting, protect the brain, rehydrate the patient, maintain physiological pH and prevent edema.

In remote cases where the patient requires transport to the cryonics facility, usually by air, a whole body blood washout is performed to enhance cooling and protect the brain against ischemia-induced perfusion impairment during cryoprotective perfusion.

In ideal circumstances where there is a negligible delay between pronouncement of legal death and the start of cryonics stabilization procedures, viability of the brain by contemporary criteria can be maintained until the early stages of cryoprotective perfusion, after which the aim becomes excellent ultrastructural preservation of the brain. In general, the objective of applied cryonics research is to delay the loss of cerebral viability to progressively later stages. One recent development that aims to prevent fracturing is to maintain patients at a temperature just below the glass transition temperature of the vitrification solution (-123 degrees C for M22). Prototypes of such intermediate temperature storage units have been designed for neuro and whole body patients. A number of neuropatients at Alcor are stored at intermediate temperatures.

Anticipated near-term developments in cryonics technologies include the use of cyclic lung lavage with chilled perfluorocarbon liquid to increase the cooling rate of cryonics patients during stabilization, enhanced computer control of whole-body cryoprotectant perfusion, and the conduction of

cryoprotectant perfusion with vitrification solutions at remote locations, with subsequent transport of the patient at dry ice temperatures.

## **Cryonics and Suspended Animation**

The most controversial aspect of cryonics is the likely delay between stabilization of the patient and treatment. It is often assumed that cryonics would gain in credibility if this separation between stabilization and treatment could be overcome.

This belief rests on the confusion of the ideas of suspended animation and cryonics. It is certainly the case that the technological feasibility of cryonics will appear more plausible if humans can be recovered from liquid nitrogen temperatures without any adverse effects, but perfecting human suspended animation would not make cryonics redundant because the defining feature of cryonics is to stabilize patients that cannot be treated by contemporary medicine. As long as there are diseases and traumatic events for which there are no cures or treatments, cryonics will remain available as an experimental form of critical care medicine.

A related misunderstanding is the failure to distinguish between the practice of cryonics and the science of cryobiology. Almost as old as the idea of cryonics is the objection that it is unethical and unscientific to offer a procedure that has not been proven to work. As should have become clear from the preceding exposition, cryonics cannot be proven to work because its defining feature is to stabilize a patient who cannot be treated by contemporary medicine in anticipation of future medical advances. As such, cryonics should not be evaluated as an experimental science but as a form of decision-making under conditions of uncertainty.

In its most abstract form the argument in favor of cryonics is a variant of Pascal's wager: People who do not make cryonics arrangements are in the control group, and those who make cryonics arrangements are in the experimental group. So far the control group is not doing very well and the fate of those who have made cryonics arrangements is uncertain.

A variant of this argument is to present cryonics as the conservative medical course of action. We do not know if critically ill patients can be

resuscitated and restored to health in the future, but we cannot err on such serious matters of life and death.

Some advocates (and critics) of cryonics have gone a step further and have assigned probabilities to the prospect of successful resuscitation of cryonics patients. This approach raises a lot of complicated issues. For example, should such estimates concern only scientific and technical events or should social and legal events be included as well? Obviously, it is important to distinguish between events that are independent and dependent to perform meaningful probability calculations, which pose a non-trivial problem.

A more fundamental objection was raised by the mathematician and cryonics activist Thomas Donaldson, who argued that revival is not an independent event that will occur beyond our control but will be subject to the efforts of cryonics advocates. It should also be noted that the very question about the probability of revival is problematic because cryonics patients have been cryopreserved under a wide variety of circumstances ranging from cases with minimal ischemic delay, rapid cooling, and good equilibration of the vitrification solution to cases where the patient has been frozen in the absence of a cryoprotective agent after a long ischemic interval.

As a form of decision making under uncertainty, cryonics cannot be comprehensively proven, but progress in experimental science can progressively move conditions that must be met to resuscitate cryonics patients from the domain of informed speculation to science fact. Ultimately, the only element of uncertainty left in the cryonics program will concern the fate of a patient whose condition cannot be treated by the prevailing state of medicine.

## **Cryonics as an Elective Medical Procedure**

Our growing understanding and recognition of the neuroanatomical basis of identity, and progress in neural cryobiology and regenerative medicine, will progressively pressure medicine to abandon cardiovascular criteria for pronouncement of death in favor of procedures to preserve personhood until medical treatment will be available in the future. The growing recognition that

patients should not be abandoned simply because other organs give out will increase demand to accept cryonics as an elective medical procedure.

Broader acceptance of this concept will also transform the nature of human cryopreservation from a form of emergency medicine to a form of experimental critical care medicine. As a consequence, the ischemic delays and improvised volunteer-driven care that characterizes contemporary cryonics will give way to the performance of cryonics procedures in the hospital, and the development of human cryopreservation as an evidence-based branch of medicine.

Although current cryonics organizations try to make the best of an unfavorable situation by employing standby teams to reduce brain injury, much improved quality of care would be possible if cryonics procedures could start at a point where medical professionals (with informed consent of the patient and/or family) would determine that further treatment of the patient with contemporary technologies would be futile, or even counter-productive.

When this determination is made, conventional life support for the patient would be terminated and deep hypothermia would be induced using cardiopulmonary bypass. At deep hypothermic temperature, the patient's blood would be substituted with an organ preservation solution to reduce blood complications associated with lower temperatures. When the patient's core temperature approached the freezing point of water, the organ preservation solution would be replaced by a vitrification agent to allow an ice-free descent to cryogenic temperatures for long term care. After lowering the patient's temperature below the glass transition point, the patient would be maintained at intermediate temperatures to reduce the risk of thermal stress and fracturing that would occur at lower cryogenic temperatures.

Cryonics as an elective medical procedure will not just be an option for those who have been diagnosed with a terminal disease, but will also present a new paradigm to treat patients who suffer severe ischemic attacks or traumatic brain insults. In current medical practice, when such patients are successfully resuscitated, the predominant outcome is a persistent vegetative state or minimally conscious state (MCS). Such outcomes trigger much debate among medical caregivers, lawmakers, and bioethicists concerning the moral status of

such patients, the authority of relatives to withhold treatment, and the allocation of medical resources.

It is now a well-established scientific finding that brain cells do not immediately “die” after severe hypoxic insults such as stroke or cardiac arrest. Actual necrosis (or apoptosis) takes many hours, or sometimes even days (as a result of a phenomenon called “delayed neuronal death”). Unfortunately, ischemic insults to the brain exceeding 5-10 minutes are often sufficient to set parts of the brain on an irreversible path to destruction, even if resuscitation of the patient is possible. Currently, there is no single approved neuroprotective agent that can protect these brain cells. Although hyperacute combination therapy and postresuscitation hypothermia may offer hope for people suffering severe hypoxic insults, most of such patients currently would be better served by placing them in a state of biostasis before the complete ischemic cascade can complete its course.

Although cryonics is often dismissed as speculative, it can be persuasively argued that long term preservation of the neuroanatomy of such patients through vitrification offers better prospects for recovery of the person than the current practice of resuscitation after the insult. Such a practice could also offer a truce between those who advocate that life should be maintained at all cost and those who advocate a definition of death that involves the presence of personhood.

## **Legal Recognition of Cryonics**

We may assume that as cryonics continues to grow it will at some point be covered by specific regulations. So far there has been little consensus about the legal framework that cryonics will need to operate in. As a consequence of publicity surrounding the cryopreservation of baseball legend Ted Williams by Alcor, the Cryonics Institute in Michigan was legally designated as a cemetery. Such a regulatory approach treats cryonics patients as dead people without legal protection beyond the regulations that cover cemeteries. Another consequence of this unfortunate designation is that cryoprotectant perfusion needs to be performed under the supervision of a licensed funeral director. An alternative approach has been pursued by the Alcor Life Extension

Foundation, which receives its patients under the Uniform Anatomical Gift Act (UAGA).

The current lack of meaningful legal recognition of people in cryostasis presents two problems. First, it prevents patients from employing the most effective stabilization procedures to inhibit brain injury after pronouncement of legal death. This reinforces the perception that cryonics is a futile attempt to preserve the brain. In fact, the ischemic delays that are routinely associated with contemporary cryonics are not an intrinsic property of cryonics itself, but the logical consequence of the lack of legal protection of cryonics patients.

If cryonics is recognized as an elective medical procedure, or the practice of cryonics is recognized at least to such a degree that there can be a smooth transition between the terminal phase of the patient and the start of cryonics procedures, such undesirable events will be greatly reduced. In the case of unexpected death, homicide, or other unnatural events, mandatory autopsy requests will seriously interfere with efforts to protect the brain of the patient.

The second problem following from the lack of legal recognition of cryonics patients is that medical and legal practice will be increasingly out of sync with scientific and bioethical developments. One of the two accepted criteria for determination of death—irreversible cessation of all functions of the brain—requires a serious reconsideration of the legal status of cryonics patients in light of recent developments in neural cryobiology. If scientists, medical practitioners, and bioethicists learn more about the ability to restore organized electrical activity after vitrification of brain slices and, in the foreseeable future, whole brains, cryonics patients can no longer be considered dead using brain death criteria. Cardiorespiratory criteria will also be inadequate, just as patients undergoing hypothermic circulatory arrest procedures are not considered dead.

One important issue in the upcoming debate concerning the legal status of cryonics patients will revolve around the concept of reversibility. The question of whether cryonics patients will be revived in the future cannot be answered by consulting contemporary scientific and medical knowledge. This characteristic of cryonics would seem to set cryonics apart from other medical procedures, but upon closer inspection such a distinction fails to recognize that

all medical prognoses are probabilistic in nature. The question, therefore, is what kind of expectations can be considered reasonable in light of the existing experimental research and what the ethical consequences are if we come down on either side of the issue.

The issue of reversibility also draws attention to the question of what should be considered a successful resuscitation. In contemporary medicine it is not conventional wisdom to consider a treatment for a serious disease or insult a failure if the person is not restored in exactly the same state as before the event. As a matter of fact, significant segments of modern society believe that medical care should be continued even if there is empirical evidence that the neuroanatomical basis of personhood has been irreversibly damaged. From this perspective, the objective of cryonics looks relatively modest in comparison because it incorporates a modern recognition of what it means to be human.

## **Contributions of Cryonics Research**

Many scientists who are sympathetic to the objectives of human cryopreservation nevertheless claim that cryonics research risks reallocation of resources from more legitimate research efforts. This is a misunderstanding, for two important reasons. The first reason is that it cannot be assumed that cryonics research funding is competing with mainstream cryobiological research. Most of the financial support aimed at researching cryonics procedures has originated from individuals and organizations who have taken an interest in cryobiology for the sole reason of developing and perfecting technologies to place critically ill people in cryopreservation.





*Figure 2-3. Cryoprotective perfusion preparations at Alcor in mid-2002.*

The second reason, which has more profound implications, is that cryonics research in practice aims to solve many of the same problems that are currently being investigated in mainstream cryobiology research and stroke research. Cryonics research is not just comprised of experimental work to resuscitate complex organisms from subzero temperatures, but includes research efforts such as vitrification of organs, eliminating cryoprotectant toxicity, automation of cryoprotectant perfusion equipment, multi-modal pharmacological treatment of cerebral ischemia, and other related topics.

The most profound example where the practice of cryonics has stimulated great strides in mainstream cryobiology research is the design of low toxicity vitrification agents. The desire to completely eliminate ice formation in cryonics has triggered ongoing research efforts to achieve this goal. This, in turn, has produced a stream of experimental work and peer reviewed papers that are of great practical importance to cryobiology as such. Even in the case of neural cryobiology it is hard to underestimate the importance of being able to store neural tissue without loss of viability and

ultrastructural alterations at low temperatures for neuroanatomical and pharmacological studies.

Another example of the lasting contributions cryonics can make to society is the design and experimental validation of whole body hypothermic organ preservation solution. The goal to lower a patient's body temperature to just above 0 degrees Celsius without neurological damage during cryonics stabilization procedures finds a close counter-part to efforts in emergency and military medicine to stabilize cardiac arrest patients and severe trauma victims. Efforts to design universal organ preservation solutions in cryonics have great relevance to such efforts and vice versa.

There are a number of research areas where cryonics researchers and practitioners have not only contributed to mainstream science, but where their efforts have also anticipated subsequent developments in medicine. For example, the technologies that are now being proposed to stabilize legally dead people who have elected to donate their organs have been routine in cryonics for decades; also consider the use of mechanical cardiopulmonary support devices, the induction of hypothermia, and the use of anticoagulants and neuroprotective interventions.

One researcher involved with the Alcor Life Extension Foundation anticipated and built a prototype of an inspiratory impedance threshold valve to improve cardiac output during external chest compressions before this technology was brought to the commercial market and endorsed by the American Heart Association. Cryonics research led to the development of Hextend, an artificial blood plasma substitute now used in clinical medicine. In the mid-1990s researchers associated with cryonics used combinational pharmacotherapy to resuscitate dogs from up to 16 minutes of normothermic ischemia, anticipating the growing embrace of multi-component pharmacological strategies to limit brain injury after cardiac arrest and stroke.

The importance of rapid cooling in cryonics cannot be overestimated, and cryonics researchers and engineers have put a lot of time and effort in developing practical strategies. As a consequence, the typical cooling rates that are achieved during cryonics stabilization procedures in the field routinely outperform those observed in emergency medicine and the treatment of heat stroke. Researchers who participate in the field of cryonics continue to

develop more powerful cooling methods such as the use of cyclic lung lavage, also known as liquid ventilation. When applied as a cooling method, this uses the lungs as an endogenous heat exchanger with chilled perfluorocarbon liquid. Because it does not require invasive surgery and can be achieved with endotracheal intubation, it can be applied by paramedics in the field. The most recent cyclic lung lavage technologies can produce cooling rates approaching those that were previously only possible with the use of extracorporeal bypass.

As this short survey of cryonics to the general body of knowledge and medical practice shows, there are important benefits of cryonics research that benefit science, medicine and society in general.

## **The Cultural Reception of Cryonics**

When cryonics first entered the public conscious in the 1960s, its early advocates believed that advances in cryobiology would give rise to a growing acceptance of cryonics among the general public, scientists, and medical practitioners. The expectation was that if more elements of the cryonics program would be supported by experimental science, the number of people making cryonics arrangements would continue to grow. As we know now today such an optimistic vision did not materialize. As a matter of fact, discussion of cryonics in the popular media seems strangely disconnected from the scientific, technological, conceptual, and organizational advances in cryonics. Comments from cryobiologists and bioethicists do not indicate even the most basic understanding of contemporary cryonics practices.

A persistent misconception about advocates of cryonics is that they want dead people to be frozen so that they will be revived in the future. There are no public advocates of cryonics who would phrase the case for cryonics in this matter, and not a single existing cryonics organization is offering cryonics services with a guarantee of future revival.

The objective of cryonics organizations is not to revive the dead, but to stabilize patients at low temperatures to prevent death. To accomplish this objective, existing major cryonics organizations offer stabilization services to prevent neurological damage after pronouncement of legal death and use vitrification solutions to eliminate freezing. Because even the most superficial

investigation of contemporary cryonics practices could remove these misconceptions, one wonders why such incorrect misconceptions about cryonics persist.

Having no informed opinion on the matter, an expert who is consulted on the technical feasibility of cryonics usually expresses a form of popular bias. In his own field, an ill-informed statement could cost him dearly, but in the case of cryonics there are no significant costs. Because there are no costs to holding irrational beliefs about cryonics, (presumed) experts can be rationally irrational, to use a phrase from the economist Bryan Caplan.

Another factor that contributes to the poor public quality of cryonics is that humans have not evolved to think in probabilistic terms and accept uncertainty. As a consequence, cryonics is not discussed as a subset of rational decision making under uncertainty but as a set of scientific conjectures that should be resolved first before the practice can be endorsed. In the absence of that, cryonics organizations are accused of “selling false hope.” But the fact that humans generally endorse the view that decision making can be rational in absence of absolute knowledge of future events indicates that more basic psychological mechanisms may prevent a more dispassionate assessment of the cryonics protocol.

One school of thought in cryonics attributes the limited appeal of cryonics to the temporal separation between patient stabilization and patient treatment. A decision to make cryonics arrangements is a conscious expression to permit resuscitation in a far and unknown future. In this sense, cryonics is fundamentally distinct from contemporary medical practice where no contemplation of the nature of a future existence is required as a part of medical treatment. The anxiety produced by the concept of cryonics is not confined to the person contemplating cryonics but extends to family members and close relatives.

There are numerous documented cases where partners and hostile relatives have resisted the cryonics arrangements of family members. Often such resistance is motivated by financial gain, but feelings of abandonment and lack of closure contribute as well. After a long struggle with disease, a natural response is to seek closure. Because cryonics does not provide this kind of closure, it can be seen as something that fundamentally changes the

nature of human bereavement. As such, the hostility that is sometimes encountered in public debates about cryonics does not reflect informed skepticism but anxiety that is produced by the prospect that cryonics is credible.



*Figure 2-4. James Hiram Bedford (born on 20 April 1893), a psychology professor, was the first person whose body was cryopreserved in 1967 and who remains a patient at Alcor today.*

As a consequence, advocates of cryonics are increasingly investigating the psychological, sociological, and moral topics surrounding cryonics. One notable perspective is that when the expected lifespan is inherently indeterminate, there will be a growing disposition towards human cooperation, because there will be no fixed limit to the number of individual encounters between individuals. Public policies will increasingly be aimed at long term goals and stability instead of aiming at short-term gratification on the assumption that we are all dead in the long run. In this sense, cryonics has profound transformative properties, but it would seem these will further the progress of mankind.

### **3. Protocol**

This protocol developed by the Alcor Life Extension Foundation is an ideal that may be impossible to achieve in many cases. Obstacles preventing ideal procedures include insufficient notice of impending legal death, location of death, logistics and deployment problems, and financial constraints. These are explained in more detail in the policy on Comprehensive Member Standby (CMS) on the Alcor website.

#### **Objectives**

The objective of cryonics is to stabilize critically ill patients after cardiac arrest, at cryogenic temperatures, in anticipation of future resuscitation. At Alcor, cryonics is viewed as a form of experimental critical care medicine, with members in biostasis considered patients. Because human cryopreservation is not available as an elective medical procedure, cryonics procedures can only be initiated after the pronouncement of legal death. The procedures to achieve this objective have been developed by Alcor over many years in consultation with external experts in cerebral resuscitation and tissue and organ cryopreservation.

Alcor offers whole body cryopreservation and neuro preservation. In both options the preservation of the brain as the anatomical basis of the person has the highest priority. During the initial stages of cryonics procedures the ideal objective of the Alcor protocol is to secure viability of the brain by *contemporary* biological criteria. This means that Alcor's initial stabilization procedures should not be harmful in themselves and that the reversal of these protocols should be possible in principle.

During the subsequent phase, which involves cryoprotectant perfusion and cooldown below 0 degrees Celsius to cryogenic temperatures, this objective is no longer attainable as a result of cryoprotectant toxicity and

structural injury associated with thermal stress, and is replaced by the more modest objective of good ultrastructural preservation.

## Non-Ideal Cases

The procedures described in this document are attempted under ideal logistical and biological conditions. The circumstances under which legal death occurs can be highly variable, and in many cases some or all these procedures except for cooling may be impossible. Unless members making cryopreservation arrangements express other written preferences, *it is a general principle of cryonics that cryopreservation should proceed after legal death even under poor biological conditions when standard protocol procedures cannot be performed.* This is done to preserve as much remaining biological information as possible because in most cases it is theoretically impossible to determine whether all brain information encoding memory and personal identity has been truly lost.

## Summary of Cryonics Procedures

Alcor's cryonics protocol ideally consists of four distinct elements: deployment and standby, stabilization, cryoprotectant perfusion, and cryogenic cooldown.

- 1. Deployment and standby.** If Alcor is notified of a pending case or emergency a standby team is deployed to the location of the patient to ensure rapid intervention after pronouncement of legal death.
- 2. Stabilization.** After pronouncement of legal death rapid cooling is initiated, circulation is restored, the lungs may be ventilated, and medications are administered to protect against blood clotting and keep the brain viable. In remote stabilization cases where transport to Alcor's operating room may take up to 24 hours, the blood is ideally replaced with an organ preservation solution to enhance cooling, prevent blood clotting, and protect against cold ischemia.



- 3. Cryoprotectant perfusion.** After arrival of the patient at the Alcor facility, the patient's blood (or organ preservation solution) is replaced with a vitrification solution. Circulation of this solution through blood vessels at cold temperatures partially replaces water inside cells with chemicals that reduce or prevent ice crystallization during further cooldown to cryogenic temperatures.
- 4. Cryogenic cooldown.** After cryoprotectant perfusion the patient is gradually cooled to the temperature of liquid nitrogen for long term care. In the future, as appropriately reliable equipment becomes available, cooling may terminate and long-term maintenance may occur slightly below the glass transition temperature, to minimize structural damage.

## **Deployment and Standby**

Alcor maintains a local emergency vehicle equipped with standby and stabilization equipment and at least one complete set of kits for remote deployment, and also has access to similar cryonics emergency vehicles maintained by Suspended Animation, Inc., in Southern California and Florida. Alcor also makes an effort to maintain basic or complete kits in regional areas with a high number of cryonics members. The organization determines allocation of standby resources through periodic review of the demographics and regional distribution of its members. To minimize the chance of late or last-minute deployment Alcor encourages members to inform the organization about their health situation and uses a color-coded member tracking system that guides deployment preparations and decisions.

Alcor materials are available for family, medical caregivers and third parties about its procedures to ensure an orderly and timely transition between pronouncement of legal death and the start of cryonics procedures. Alcor will also request medical data about the terminal patient to assist in determining the time and scope of deployment. Although Alcor does not participate in pre-mortem treatment of the patient, Alcor may discuss with family and caregivers

the medical management of the terminal patient. Alcor may also seek permission for placement of non-invasive monitoring devices.

Alcor maintains a Deployment Committee which normally includes its chief executive, Medical Response Director, and the Chief Medical Advisor. The committee is charged with assessing and defining Alcor's Comprehensive Member Standby policy, establishing standby deployment guidelines, and making real-time deployment decisions in emergency situations.

Unless unforeseen circumstances (such as a last-minute remote case) do not permit full deployment, Alcor stabilization protocol ideally requires four team members to be present at the start of cryonics procedures. To avoid fatigue and errors, standby team members are rotated in pairs, on a 12-hour cycle, to allow for sufficient rest and sleep. The stabilization team will typically be headed by Alcor's Medical Response Director, who is a nationally certified paramedic. Additional team members may include other Alcor staff members with EMT (emergency medical technician) training, local volunteers with cryonics stabilization training, or a Standby Team of Suspended Animation, Inc, which is composed of trained staff members and consulting professional perfusionists and surgeons. If there is insufficient notice for Alcor or Suspended Animation, Inc., to reach the location of a cryonics case before legal death, emergency stabilization may be performed entirely by local volunteer team members. At Alcor's discretion, or member choice, stabilization may also be performed entirely by Suspended Animation, Inc.

Alcor offers education and training to its members and interested medical professionals in basic human cryopreservation procedures. In addition, anyone who feels motivated to participate actively in cases may seek more advanced training. A network of volunteers and trained members may be called upon to assist in remote cases or basic logistical or stabilization tasks.

## **Stabilization**

The objective of stabilization is to maintain viability of the brain by contemporary biological criteria after legal pronouncement of death. To achieve this purpose four procedures are ideally employed:

- 1. Cardiopulmonary Support.** Circulation is restored to provide oxygenated blood to the brain and to enhance cooling. Depending on specific circumstances, the lungs may be ventilated.
- 2. Induction of Hypothermia.** The temperature of the patient is lowered to just above 0 degrees Celsius to depress metabolism.
- 3. Administration of Medications.** Drugs are administered to improve circulation, inhibit blood clotting, and to protect the brain.
- 4. Blood substitution.** If the patient is distant from Alcor's facilities, and if it is logistically possible to do so, the blood of the patient is substituted with an organ preservation solution to enhance cooling, prevent blood clotting, and protect against cold ischemia.

Cardiopulmonary support, induction of hypothermia, and administration of medications are initiated as quickly as possible after death is pronounced. In practice, none of these procedures alone is sufficient to maintain the brain in a viable state. To ensure that these interventions are executed concurrently, a minimum number of four team members will be present at the start of stabilization. Their tasks will include data collection for subsequent review and analysis.

Stabilization procedures end when either the temperature of the patient has been lowered close to the freezing point of water or when blood washout is started to prepare for cryoprotectant perfusion. In remote cryonics cases blood substitution is an option prior to transport to the cryonics facility.

## **Cardiopulmonary Support**

Cardiopulmonary support (CPS) is distinguished from cardiopulmonary resuscitation (CPR) because the objective of circulation and ventilation in cryonics is not resuscitation of the patient but to prevent (additional) ischemic injury.

The three objectives of cardiopulmonary support are:

- 1. Restore circulation of oxygenated blood to the brain.**

**2. Circulate medications.****3. Improve the rate of external cooling.**

After pronouncement of legal death the patient is transferred to the portable ice bath and mechanical cardiopulmonary support is started. Mechanical devices allow for consistent and aggressive chest compressions, permitting continued CPS during transport of the patient. They also prevent fatigue of standby team members and release team members to perform other important tasks. The preferred method of cardiopulmonary support is battery-powered mechanical active-compression decompression. The second preferred option is gas-powered mechanical active-compression decompression. The third option is gas-powered conventional mechanical chest compression. When mechanical devices are not available or not functional, manual compression-decompression chest compressions should be initiated through the use of the Cardiopump. Conventional (i.e., hands only) chest compressions should only be pursued when all other options are exhausted.

In line with recent CPR guidelines, Alcor emphasizes the importance of continuous and vigorous chest compressions. Continuous chest compressions induce moderate air movement in and out of the lungs, help to mitigate the risk of reperfusion injury and hyperventilation when metabolism is depressed by hypothermia.

If medical professionals are available to place a secure airway to initiate positive pressure ventilation an inspiratory impedance threshold valve (ITV) should be placed between the endotracheal tube (or King Airway) and the oxygen source to prevent ventilations during the decompression phase of chest compressions. The goal is to maximize cardiac output. The chest compression-to-ventilation ratio is 30:2 and should be reduced to 60:2 below 32 degrees Celsius. *No positive pressure ventilations should be initiated after 30 minutes of normothermic circulatory arrest.*

Unless surgical expertise is available to perform surgery with minimal interruption of circulation, CPS should continue until the patient has reached a core temperature of 20 degrees Celsius to prevent ischemic injury during preparation for blood substitution or cryoprotective perfusion.

## **Induction of Hypothermia**

External cooling of the patient should be started immediately after pronouncement of legal death to depress metabolism. The patient is moved from the bed to a portable ice bath (PIB) that contains ice and cold water to facilitate cooling during transport, and increase cooling rate. The patient should be completely immersed in ice and water with a primary emphasis on the head and areas with major surface vessels such as the neck, axilla and groin. Because the total area of contact between dry cubed ice and the patient is inevitably limited, some water is essential, to maximize heat transfer. It should cover as much of the patient's skin as possible, and is circulated via a system of perforated tubing attached to a submersible pump. Water is flowed rather than sprayed over the patient, to reduce the risk of infection via airborne droplets if the patient has a contagious disease.

Concurrent start of aggressive cardiopulmonary support increases the cooling rate by moving warm blood from the core of the patient to the surface for heat exchange. The objective of all these procedures is to achieve the fast cooling rates that are seen in cold water immersion without sacrificing cardiopulmonary support and medication administration.

A minor degree of internal cooling during stabilization can be achieved by cooling the medications and fluids before they are administered. Mannitol should be exempted from this procedure because the solution will crystallize if it is maintained at low temperatures.

Cooling the patient should continue without interruption during transport to the funeral home or during surgical procedures. Logging the temperature of the patient is important to monitor the effects of cooling efforts and for subsequent case reporting.

Because even the fastest cooling rates cannot stay ahead of ischemic injury without circulation of oxygenated blood and administration of neuroprotective medications, induction of hypothermia cannot be a substitute for these interventions. This is particularly important during the start of stabilization procedures because energy depletion is running faster than cooling can depress metabolism.

If no ice bath is available, a heavyweight body bag can be used to surround the patient with ice without spilling and leaking.

In typical cases, the patient should not be cooled below the freezing point of water (0 degrees Celsius). The patient may only be cooled below the freezing point of water if Alcor has made the decision that long time delays before stabilization, or expected during transport, will make cryoprotectant perfusion impossible. In such cases the patient must be held at the temperature of dry ice (-78.5 degrees Celsius), with the understanding that this will inflict very severe brain injury as a result of freezing. If a patient is frozen, special care must be taken to avoid thawing and re-freezing, which will cause even more damage. The application of dry ice without cryoprotectant perfusion (so-called “straight freezing”) should be viewed as a desperation measure which cannot be reversed.

## **Administration of Medications**

Administration of medications should be started as soon as the patient has been placed in the portable ice bath. If the patient already has a patent intravenous line in place, or if no portable ice bath is available, the administration of the first medications can start sooner. Under no circumstances should Alcor team members start or authorize the administration of medication prior to pronouncement of legal death.

Each medication falls into one of four categories:

- 1. Small volume medications** (such as heparin and streptokinase)
- 2. Large volume fluids** (such as hydroxyethyl starch and mannitol)
- 3. Fluids that require gastric administration** (Maalox)
- 4. Medications to add to blood washout solution**

The administration of the small-volume medications and the large-volume fluids should commence at the same time. This is particularly important if the patient is severely dehydrated at the start of stabilization procedures. The simultaneous administration of the small-volume medications

and the large-volume fluids can be achieved either by pushing the small medications into the line or by establishing a second IV line.

If there is no delay between pronouncement of legal death and the start of stabilization procedures the full set of medications should be administered.

### *Small Volume Medications*

**1. Propofol** (200 mg - fixed dosage). Propofol is a *general anesthetic* and is used for two reasons. The first reason is to *reduce metabolism of the brain* to reduce oxygen and glucose requirements, and the second reason is to *prevent the theoretical possibility of recovery of awareness* due to aggressive cardiopulmonary support.

**2. Sodium Citrate** (10 grams for patients < 40 kg, 20 grams for patients > 40 kg). Citrate is an *anticoagulant* that prevents the formation of blood clots that can interfere with blood circulation and cryoprotective perfusion. By chelating calcium, it also prevents autoresuscitation of the heart. It is administered as a custom formulation of 20% w/v sodium citrate in water, packaged in 50 mL sterile vials.

**3. Heparin** (50,000 IU – fixed dosage). Heparin is an *anticoagulant* that prevents the formation of blood clots that can interfere with blood circulation and cryoprotective perfusion. Heparin loses effectiveness at low pH (pH < 6.7), so control of pH is important during a cryonics stabilization. This is why other anticoagulants are also important.

**4. Vasopressin** (40 IU – fixed dosage, second 40 IU dose concurrent with Vital-Oxy). Vasopressin is a *vasopressor* that is used to increase blood pressure during cardiopulmonary support. There is no need to administer vasopressin if the patient's temperature is near or below +20 degrees C at time of administration as it is ineffective at cold temperatures.

**5. Minocycline** (200 mg- fixed dosage dissolved in 10 mL saline). Minocycline is a *broad spectrum bacteriostatic antibiotic and free radical scavenger* with good tissue and brain penetration that possesses a broad variety of neuroprotective properties including inhibition of metalloproteinases, iNOS, PARP, mitochondrial cytochrome c release and, apoptosis.

**6. SMT** (S-methyl-isothiourea) (400 mg – fixed dosage dissolved in 10 mL saline). SMT is a *neuroprotectant* (iNOS inhibitor) that is used to protect the brain from ischemic injury. SMT also raises blood pressure.

### *Large Volume Medications*

**7 & 10. Decaglycerol/THAM** (2 x 200 ml- fixed dose). Decaglycerol is a *glycerol polymer* used to osmotically inhibit cerebral edema similar to mannitol. THAM is a buffer that is used to mitigate acidosis. Decaglycerol/THAM is administered as a custom formulation of 20% w/v decaglycerol and 4.5% w/v THAM (tromethamine) in water, packaged in 2x 200 ml sterile vials. The first 200 ml dose should be administered (I.V. push) after completion of small volume medications administration, and the second 200 ml dose is to be administered upon completion of administration of all other medications.

**8. Vital-Oxy** (formerly known as Oxynil) (0.7 ml/kg up to 70 mL, dissolved in 150 mL saline). Vital-Oxy is a *proprietary mixture of antioxidants and an anti-inflammatory agent* developed by Critical Care Research, Inc., each mL of which contains 3.23 mg PBN (alpha Phenyl t-Butyl Nitron), 1.55 mg melatonin, 195 IU d-alpha-tocopherol (vitamin E), and 1.55 mg carprofen in an emulsion of Cremophor EL and 155 mg ethanol in water.

### *Fluids That Require Gastric Administration*

**9. Maalox** (250 ml – fixed dosage). Maalox is an *antacid* that is used to stabilize the pH of stomach contents to prevent erosion of the stomach wall by hydrochloric acid at low temperatures. Failure to prevent this can lead to contamination of the circulatory system with stomach contents and abdominal swelling during later perfusion.

### *Optional Medication*

**11. Hetastarch** (250 ml – fixed dosage). Hetastarch is a *volume expander* used to restore volume in dehydrated patients and increase cerebral perfusion during CPS.



### *Washout Medication*

**12. Streptokinase** (250,000 IU – fixed dosage dissolved in 5 to 10 mL normal saline). This is added to washout solution prior to remote blood washout or first cryoprotection flush in the OR).

### *Abbreviated List of Medications*

If there is a delay of more than one hour after cardiac arrest, an abbreviated list of medications should be administered.

**1. Sodium Citrate** (if available) (10 grams for patients < 40 kg, 20 grams for patients > 40 kg).

**2. Streptokinase** (250,000 IU – fixed dosage).

**3. Heparin** (50,000 IU – fixed dosage).

**4. Tempol** (if available) (5 g – fixed dosage - dissolved in 20 ml normal saline). Tempol is a low molecular weight superoxide scavenger used to mitigate ischemia-induced free radical damage. It is used only in the Abbreviated protocol.

**5. Minocycline** (200 mg dose- fixed dosage).

**6. Decaglycerol** (200 ml- fixed dosage).

**7. Maalox** (250 ml –fixed dosage for gastric administration).

**8. Streptokinase** (250,000 IU - fixed dosage - add to blood washout solution prior to remote blood washout or first cryoprotection flush in the OR).

Administration of these medications should be followed by at least ten minutes of chest compressions to distribute the medications, accompanied by surface cooling.

### *Additional Considerations*

Vasopressors such as epinephrine or vasopressin should ideally be administered intermittently to ensure higher cerebral bloodflow. The effects of vasopressor medications can be assessed through the use of end tidal CO<sub>2</sub> monitoring. Protocols may reduce administrations of vasopressors to a limited number of discrete injections for simplicity.

Maalox is not introduced to the circulatory system but to the stomach of the patient. This requires the placement of the *double-lumen* King LTS-D

Airway or a designated gastric tube. Unless placement of the King LTS-D Airway is not possible, the King LTS-D Airway is the preferred method for Maalox administration because it allows for simultaneous ventilation. Maalox should only be administered through the inserted gastric tube in the rear channel of the KING LTS-D Airway if the team leader has received confirmation that the KING LTS-D has not been accidentally placed in the trachea. A gastric tube should only be placed by an experienced medical professional.

If Alcor is not successful in persuading the patient's caregivers to leave an IV line in place, the preferred method of medication administration is intraosseous infusion. If intraosseous infusion is not available, or contraindicated for the patient, an experienced team member should place a peripheral IV line. Central IV lines should only be placed by qualified medical professionals. Techniques such as pressure infusion should only be used by those with extensive experience such as paramedics.

Preparation of the medications should start at least one hour before the estimated time of circulatory arrest or on the way to the patient if (s)he has already been pronounced. Compounds that have been prepared in-house at Alcor should be filter-sterilized prior to administration. Mannitol should be checked for crystals before administration. If there are crystals in the solution the solution should be warmed to dissolve them. If the crystals cannot be eliminated the fluid should not be introduced to the patient.

In instances where team members are uncertain about dosage, methods of administration, or other issues, they can contact Alcor's medical advisor, who should be available by phone at all times during standby, stabilization, and transport of the patient. Team members should not improvise on their own initiative.

The start of blood washout or cryoprotective perfusion should not be delayed to complete administration of medications. If administration of the remaining medications is still deemed desirable they can be added to the organ preservation solution during perfusion.

## **Remote Blood Substitution**

In remote cases, blood substitution with an organ preservation solution prior to transport at hypothermic temperatures is desirable unless it is logistically impossible to do so. Remote blood substitution has the following objectives:

- 1. Rapid induction of ultraprofound hypothermia.**
- 2. Prevention of clotting, red cell sludging and “no-reflow.”**
- 3. Maintaining viability of the brain during transport.**

Alcor uses an Air Transportable Perfusion circuit (ATP), or, if available, the Stockert SCPC portable clinical perfusion system, to replace the blood of the patient. The organ preservation solution of choice at Alcor is MHP-2. MHP-2 is an asanguineous hyperosmolar intracellular whole body organ preservation solution with the following composition:

### *Composition of MHP-2*

Mannitol	170 mM
Adenine-HCL	0.94 mM
D-ribose	0.94 mM
Sodium bicarbonate	10 mM
Potassium chloride	28.3 mM
Calcium chloride	1 mM
Magnesium chloride	1 mM
HEPES	15 mM
Glutathione	3 mM
D-Glucose (Dextrose)	5 mM
Hydroxyethyl starch	50 g per L
Heparin	1000 I.U. per L
Insulin	40 I.U. per L
Osmolality	388-403 mOsm
pH	8.0-8.2

To facilitate rapid cooling, MHP-2 should be kept as close as possible to the freezing point of water (0 degrees Celsius). A heat exchanger built into the ATP circuit is designed to reduce the temperature to near freezing, if necessary, before the solution enters the patient. Heparin and insulin should be added to MHP-2 during extracorporeal circulation. At this point, any remaining stabilization medications (with the exception of Maalox) can be injected into the circuit as well.

Remote blood washout should only be undertaken in the absence of contra-indications for this procedure. The contra-indications for remote blood substitution range from “pre-mortem” patient pathologies to practical and logistical challenges:

#### *Contra-Indications for Remote Blood Substitution*

- More than six hours since legal death occurred.
- Omitting remote blood substitution will reduce transport time significantly.
- Reaching the nearest funeral home or other location that allows blood substitution will result in excessive cardiopulmonary support times
- There are no team members with extensive experience and knowledge of cardiopulmonary bypass present on the case
- Inspection of the blood organ preservation solution (MHP2) reveals bacterial growth
- Inspection of the blood organ preservation solution composition suggests errors in perfusate composition
- The presence of systemic edema (fluid accumulation throughout the body) that may have occurred during cardiopulmonary support
- Active gastrointestinal bleeding at the time of cardiac arrest

- Prolonged splanchnic ischemia or severe abdominal swelling
- Severe pulmonary edema
- Severe cerebral edema
- Prolonged periods of warm cerebral ischemia

### *Procedure*

To facilitate a smooth transition from cardiopulmonary support to blood substitution Alcor will normally attempt to deploy a team of at least two individuals to a cooperating funeral home to set up and prime the perfusion circuit. These team members should also obtain additional ice to further cool the patient and to be used as the heat exchange medium during blood washout. In some cases (e.g., home hospice) remote blood substitution may be possible at the patient's bedside. This option should be discussed with the patient, the patient's medical surrogate, and medical caregivers in advance.

Remote blood substitution requires surgery and cannulation of the major blood vessels of the patient. The preferred procedure at Alcor is femoral-femoral cannulation. Most surgical alternatives to femoral cannulation can cause complications during cryoprotective perfusion and should only be performed by experienced surgeons in absence of the contra-indications for remote blood substitution.

Interruption of circulation should be minimized during surgery. This is particularly important if surgery is initiated when the patient's core body temperature is still close to body temperature. If extended interruptions of circulation are expected during surgery, the procedure should not be initiated until the patient's core body temperature has been lowered to 20 degrees Celsius. Cooling should never be halted during surgery; the patient should remain surrounded by ice.

As a general rule, Alcor abstains from remote blood substitution if there are no experienced clinical or research surgeons on the team (unless it is determined that a local funeral director has the required experience to do the surgery and cannulation). Alcor's staff paramedic has received the requisite surgical training, and surgeons qualified for cryonics vascular access may also

be supplied by Suspended Animation, Inc., or Critical Care Research, Inc., under contract to Alcor. If there is uncertainty or debate about the presence of any of the contra-indications, Alcor shall abstain from remote blood substitution.

Remote blood substitution should only be initiated when there is either a functional ATP or a conventional perfusion circuit present. The use of embalming pumps is not permitted because such pumps do not permit adequate control and monitoring of pressure.

The purpose of the initial stage of blood substitution is to wash out the blood of the patient. When the venous effluent of the patient indicates that the blood has been washed out (as evidenced by a clear color or no further changes in color), the ATP is switched from “open circuit” (washout) mode to “closed circuit” (recirculating) mode, and MHP-2 continues to circulate through the heat exchanger until the core temperature of the patient approaches the freezing point of water. Generally speaking, the ATP is stopped when core patient temperature falls below 5 degrees Celsius, although the procedure may be aborted before this point if there is a special advantage in doing so, such as the need to coincide with available air transport schedules. The patient should be prepared for transport after closing the surgical incisions.

If practical to do so, the patient should be weighed prior and after completion of blood substitution if this capability is available at a funeral home.

## **Patient transport**

For cases where the location of the patient is accessible more quickly, overall, by ground than by air, Alcor employs an emergency vehicle that maintains at least all the equipment that is available for remote stabilizations. Periodic inventory check-ups and test drives should ensure that the emergency vehicle is always immediately available for casework. In a typical local case the Alcor vehicle is parked close to the location of the patient. During standby the vehicle can also be used for drawing up medications and assembling equipment. The vehicle is equipped with a lift gate to transfer the portable ice

bath into the vehicle. Parking should permit sufficient room for the lift gate to operate.

If the patient is located outside of the practical range of Alcor's emergency vehicle, the patient will be transported to Alcor's operating room by scheduled airline or, if appropriate financial arrangements have been made, by air ambulance. The patient is placed in a case for the shipment of "cadavers" (often a Ziegler case). This is insulated and attached to a tray which is typically used for air shipment and should be available from any mortuary. A cardboard shell is then placed over the Ziegler.

The standby team should take great care to ensure that the case does not leak water or body fluids because such events can result in the shipment being taken off the plane and held for inspection. To prevent leakage of body fluids, the patient should be placed in a body bag surrounded with ice inside the Ziegler case. To prevent leakage of water from melting ice, the ice should be placed in large (2.5 gallon) Zip Loc bags.

The quantity of ice should be sufficient to allow for at least 48 hours of transport. This quantity will vary according to the patient's weight and body temperature at the time of shipment, subject to the different ice restrictions imposed by different airlines. A chart may be provided for guidance on this topic.

If ice has been stored in a freezer, care should be taken that it has warmed to 0 degrees Celsius and is actively melting before packing with a cryonics patient. If a bag of ice has visible white frost on it, then it is too cold to use. Bags suspected of being too cold should be warmed by running water over them until all the ice inside is visibly wet and melting.

If airline regulations do not permit shipping the patient with water ice, hypothermia can be maintained by cold packs. Alternatively, Terra-Sorb hydrogel crystals can be mixed with bagged ice, using 2 teaspoons of hydrogel crystals per gallon of ice. This will convert liquid water into a gel that cannot leak. Like ice bags, cold packs and hydrogel ice bags should always be warmed enough that they don't have frost on them. Condensation of liquid water on bags or ice bags standing in room air is normal and expected.

At least one team member should be in the same airplane as the patient to intervene with airline personnel and serve as an advocate for the patient if

there are unexpected delays or complications. Temperature of the patient should be logged during transport. This temperature logger should not be the same as the one that was used during stabilization, to prevent data from being lost during transport or handling.

## **Monitoring of Stabilization Procedures**

A standby team should include one designated scribe. The main task of the scribe is to collect data and record observations during the case. At a minimum, the scribe should record and describe all the pertinent events during a case, including the following:

- Deployment and case preparation
- Medical data of the patient obtained from medical caregivers
- Time of pronouncement of legal death
- Start and completion of stabilization procedures
- Start and completion of cardiopulmonary support
- Start and completion of initial cooling
- Time of IV placement
- Time of administration of all the medications and fluids
- Intermittent temperature data
- Start and completion of surgery
- Start and completion of blood substitution
- Intermittent pressure data during blood substitution
- Any interruptions of procedures and unusual events
- Start and completion of preparation of the patient for transport



Nasal *and* rectal temperatures should be logged from the start of stabilization procedures until the completion of stabilization procedures.

End tidal CO<sub>2</sub> measurements should be collected during cardiopulmonary support. If available, a digital end-tidal CO<sub>2</sub> should be used because it provides more detailed information about the efficacy of cardiopulmonary support.

If enough personnel and expertise are available, blood samples (blood gases and electrolytes) should be collected immediately after pronouncement of legal death and at intermittent points during stabilization procedures. These samples should be sent to a lab for independent analysis.

Prior to the start of blood substitution, a sample of the organ preservation solution should be collected for in-house quality assurance purposes.

It is important to note that a scribe should go beyond merely writing down numbers. All kinds of observations are valuable, and indeed they may be crucial, at a later date, in understanding what happened during a case, and why. In addition, we strongly believe that photographs and video of procedures should be created to document a case, provided that interested parties such as relatives, medical personnel, and mortuary staff permit this. While some people have expressed concern that visual materials may be stolen or placed in public forums, we feel that they can actually protect the cryonics organization and its personnel by demonstrating that procedures were carried out conscientiously. If there is anxiety about the possible theft of records, surely the answer to this problem is to protect the records from theft, rather than to stop creating records. Alcor's sign-up documents clearly state that cryonics is an experimental procedure. Any experimental procedure should be documented as completely as possible, so that others can learn from it, and procedures can be improved.

At a minimum, the team leader should be equipped with a voice recorder to document important events as they occur. Scribe notes and voice recordings are essential for constructing a correct timeline of the case. A separate scribe sheet is available for data collection during the terminal phase. All scribe sheets and voice recordings should be surrendered to designated Alcor representatives after completing the case, and a signed, formal acknowledgment of receipt should be obtained.

## **Cryoprotective Perfusion**

Cryoprotective perfusion is the core procedure of Alcor's human cryopreservation protocol. Without the introduction of a vitrification solution, extensive damage to the brain should be expected. To achieve good morphological preservation of the brain, the blood (or organ preservation solution) in the patient is replaced by a vitrification solution. Alcor's vitrification solution, M22, is licensed from 21st Century Medicine, Inc. It is the least toxic vitrification solution known in peer reviewed literature for its concentration, and provides strong protection against ice formation at slow cooling rates.

### *Composition of M22*

Dimethyl sulfoxide	22.305% w/v
Formamide	12.858%
Ethylene glycol	16.837%
N-methylformamide	3.0%
3-methoxy-1,2-propanediol	4.0%
Polyvinyl pyrrolidone K12	2.8%
X-1000 ice blocker	1.0%
Z-1000 ice blocker	2.0%

A modified version of M22 is used to mitigate edema during the perfusion of whole body patients. In both whole body and neuro patients, M22 is introduced in a hypertonic carrier solution called LM5.

### *Composition of LM5*

Glucose	90 mM
Mannitol	45 mM
Alpha-Lactose Monohydrate	45 mM
Potassium Chloride	28.2 mM
Potassium phosphate dibasic trihydrate	7.2 mM
Gluthathione reduced)	5 mM
Adenine HCl	1 mM

Sodium Bicarbonate

mM

The concentration of these LM5 solutes is the same in the base perfusate (starting perfusate), and the M22 solution that is added to the base perfusate, so that the concentration of these LM5 carrier solution solutes remains constant during the whole process of cryoprotectant perfusion.

### *Cryoprotective Procedures*

After arrival at the Alcor facility, a median sternotomy will be performed to cannulate the great vessels of the heart (aorta and right atrium) for whole body patients. Vascular access surgery for whole body or neuropatients at Alcor is typically performed by a contract surgeon.

If cardiopulmonary support (CPS) is to be stopped during surgery, it is desirable for the patient to be cold enough for the brain to suffer minimal additional injury during the interval of stopped blood circulation. The usual rule during the years 2013 to 2018 has been to continue CPS until the patient temperature reaches +20 degrees C, or the brain cooling rate slows to approximately 0.1 degrees C/minute, whichever comes first. This is a cold enough temperature for the brain to be minimally injured by contemporary medical criteria even if circulation is stopped for 30 minutes. Faster surgical methods for reducing circulatory arrest times to as little as ten minutes can permit CPS to stop, and surgery to begin, at temperatures as warm as +28 degrees C. CPS shouldn't be stopped at patient temperatures warmer than +30 degrees C unless there is reason to believe that perfusion of the brain is seriously impaired.

After surgical cannulation is complete, the first step is to wash out the blood (or prior organ preservation solution) with B1 base perfusate. B1 consists of LM5 plus 1 mM calcium chloride dehydrate, plus 2 mM magnesium chloride hexahydrate, plus a proprietary additive that reduces edema.

After this step has been completed, the concentration of M22 solutes in carrier solution should be slowly ramped up in a linear fashion by progressively adding "M22 concentrate" (1.25 times normal concentration of M22 non-carrier solutes in LM5 carrier solution) to the circulating B1 base

perfusate. The objective is to linearly increase the concentration of cryoprotectants in the circulating perfusate so that the arterial concentration of M22 solutes reaches 50% of target concentration in 100 minutes. The target concentration is the concentration of M22 solutes shown in the M22 composition table above, a concentration which can be created in the laboratory for refractometer calibration purposes by diluting a sample of M22 concentrate (1.25 times concentrated M22) with a 25% additional volume of B1 base perfusate.

When the arterial cryoprotectant concentration reaches 50% of target concentration, the rate of concentrate addition should be reduced to hold the arterial concentration near 50% while the venous concentration catches up. During this time, the arterial perfusion temperature should be dropped from near +3.5 degrees Celsius to -3 degrees Celsius. When the venous effluent of M22 approaches 50% of target nominal M22 concentration as measured by manual inspection of refractive index, the concentration of M22 should be rapidly increased to between 100% and 105% of target concentration. Perfuse an arterial concentration near 105% nominal (1.05x) M22 until a bilateral venous concentration of 100% nominal M22 is reached, or until 60 minutes passes, *whichever is last*. In cases in which the venous concentration greatly lags due to poor flow, try to limit the time spent perfusing the final plateau to two hours, and never more than four hours. If burr hole observations show evidence of profound cerebral edema / elevated intracranial pressure, perfusion of the patient should be stopped.

In neuro patients, only the head is perfused, through the carotid arteries. This procedure permits faster cooling rates, bilateral monitoring of the brain, and has been observed to produce reduced burr hole drainage and facial edema. If there is evidence that the Circle of Willis is incomplete, or damaged, the vertebral arteries should be cannulated as well. Otherwise they are clamped. During isolated head perfusion the head is secured in a cephalic enclosure and the venous return is filtered before being partly returned to the patient.

Perfusion pressure during cryoprotective perfusion should not exceed 100 mmHg for both neuro and whole body patients, measured in the arterial line. Because cryoprotectant concentration and lower temperatures both

increase viscosity the pump speed needs to be reduced a number of times in the course of perfusion. Not exceeding 100 mmHg is particularly important in ischemic patients and patients with brain swelling. Perfusion pressures below 80 mmHg should be avoided.

In all cases, Alcor introduces its vitrification solution by ramping up the concentration of the cryoprotectant components linearly to avoid osmotic injury that would occur when cells are hit with a full-strength high molar solution. M22 concentrate is gradually introduced to a mixing reservoir where the solution is continuously mixed with the previously-perfused base perfusate B1 before it is introduced to the patient. The venous effluent is partly discarded (to maintain volume of the mixing reservoir as M22 concentrate is added) and partly returned to the mixing reservoir to ensure a linear increase of the ramp and to reduce M22 volumes. In whole body patients, the circuit should also include a cardiotomy sucker to recover lost perfusate from the patient's chest cavity. A subzero heat exchanger should be used to lower the perfusate temperature below 0 degrees Celsius. At Alcor, LabView software monitors the conduct of perfusion.

### *Monitoring*

Scribing and monitoring continues during cryoprotective perfusion. Collection of important data is automated, but the scribe should make an effort to document the flow of the case and record data manually, including all events that may be at all pertinent. At a minimum the scribe should record the following:

- Preparation and set-up of the cryoprotective perfusion circuit
- Time of arrival of the patient
- Time of start and completion of surgery
- Start of blood / perfusate washout
- Start of cryoprotective perfusion
- Intermittent pressure readings

- Intermittent flow readings
- Intermittent perfusate and patient temperature data
- Manual refractive index measurements
- Any interruptions of procedures and unusual events
- Completion of cryoprotective perfusion.

Visual data are even more important, during cryoprotective perfusion, than during field work. Alcor maintains a video camera that monitors events from a fixed position, but its record should be supplemented by handheld camera photographs and video showing closeup details of surgical procedures, cannulation, shrinkage of the brain visible through burr holes, and other data.

The status of the brain is visually monitored through two small holes in the skull (burr holes) made using a standard neurosurgical tool (14 mm Codman perforator). This permits observation of the osmotic response of the brain. A brain with substantial ischemic injury swells, indicating disruption of the blood brain barrier, damage to endothelial cells, or compromise of water regulation of the cells.

During cryoprotective perfusion LabView software collects cryoprotectant concentration data from inline refractometers. These measurements can be consulted to look at trends but should not be used for making decisions. Protocol decisions should be guided by manual refractive index measures that are analyzed by either benchtop refractometers or handheld digital refractometers.

If practical to do so, in neuropreservation cases the cephalon should be weighed prior and after completion of cryoprotective perfusion.

## **Cryogenic Cooldown**

After completion or termination of cryoprotective perfusion the patient will be prepared for cryogenic cooldown. A “crackphone” is placed in contact with the surface of the brain, to sonically detect subsequent fracturing events.

Whole body patients should be transferred to a large insulated cooling box,

and neuro patients to a small dewar. The cooldown process is software controlled. Liquid nitrogen is injected into the cooling box or dewar and vaporizes, drawing heat from the patient. A fan circulates the vapor to further enhance cooling. The temperature is dropped rapidly to a temperature between -80 degrees Celsius and -110 degrees Celsius. That temperature is held at that plateau for 12 hours to allow thermomechanical stress relaxation, and is then dropped more slowly over 100 hours to minimize thermal stress and fracturing. In a neuro case the final descent from around -190 degrees Celsius to -196 degrees Celsius is achieved by gradually filling the dewar with liquid nitrogen. In whole body cases the patient is transferred to a Bigfoot dewar in a precooled sleeping bag for the final descent to liquid nitrogen temperature. Because whole body transfers are done at room temperature, good logistical preparation and minimizing transfer time is of the essence.

If cryoprotective perfusion has not been possible, ice formation will start below 0 degrees Celsius. As a consequence, a slow uniform cooling rate (to minimize thermal stress caused by unequal cooling) can be maintained throughout the whole temperature range.

Temperature and crackphone data are collected by the software throughout the cooling process.

## **Long Term Care**

After cooldown to liquid nitrogen temperature (-196 degrees Celsius) the patient is maintained in a vacuum-insulated dewar until such a time in the future when resuscitation may be deemed feasible. Long-term care dewars should be equipped with level sensors and alarms. Dewar refills should follow a systematic, documented schedule.

## **Debriefing and Case Reports**

After participation in the case, team members are required to submit scribe sheets, recordings, and other notes to Alcor. Alcor should schedule a debriefing session with all case participants and advisors as soon as is convenient after completion of the case. The objective of debriefing is to

discuss strengths and weaknesses of the case in an analytical, non-confrontational manner. The debriefing session should be documented, and a transcript should be circulated among participants to check for accuracy and completeness. Usually the debriefing document should include a list with action items to be completed. A follow-up meeting should be scheduled to determine progress on these items. These action items and their completion should also be documented in the case report.

A case report should be generated, including every pertinent detail . Alcor may decide to withhold some information to protect the privacy of the patient. Case reports should be completed within 2 months after the case and should follow a general template to allow for meaningful comparisons between cases, and meta-analysis.

After completion of the case the standby coordinator and other staff members should give priority to preparing Alcor for future cases. Equipment must be retrieved, cleaned, and refurbished, and consumable supplies must be replenished. This unglamorous routine work is obviously vital to maintaining future response capability.



## **4. Legal and Ethical Considerations**

### **Introduction**

We do not expect standby and stabilization personnel to have a thorough understanding of all the legal issues raised by cryonics. Still, some grasp of the basic principles is important for three reasons:

1. Personnel should feel secure that human cryonics procedures are ethically and legally legitimate.
2. Personnel should be aware of the ethical and legal limits constraining cryonics organizations and their procedures.
3. Personnel should be sufficiently well informed to question any demand for them to venture into legal or ethical gray areas.

Caveat: The advice which we offer here is based on precedents and prior experience, but we do not have legal qualifications. This text does not claim to offer legal advice. If in doubt, always refer to the administrative staff or directors of the cryonics organization that is managing a case.

This chapter applies only to cases within the United States. Cases that occur outside the United States will be governed by statutes and regulations which are beyond the scope of this book.

An article exploring legal issues similar to those of this chapter was written by Stephen Bridge in 1994 called *The Legal Status of Cryonics Patients* (accessed at <http://www.alcor.org/Library/html/legalstatus.html>).

## **Definition and Pronouncement of Death**

Laws relating to definition and pronouncement of death in the United States are not uniform. The U. S. Constitution has nothing to say about this subject, and under the Constitution, rights not assigned to the federal government are retained by the states by default. Consequently there are no federal statutes, and a cryonics organization must deal with a confusing patchwork of state and county laws. In addition, hospitals may impose their own, narrower guidelines.

### *Definitions*

Many people who have chosen cryopreservation believe either implicitly or explicitly in the information-theoretic definition of death, which holds that death is not necessarily irreversible so long as the human brain contains information from which a person may be revived or reconstituted by future technology. By this standard, we may feel that most patients who have been cryopreserved are not “dead” in the permanent sense of the word.

Needless to say, this view is not widely accepted outside of cryonics and has no legal validity at this time.

Prior to Peter Safar’s popularization of cardiopulmonary resuscitation, death was usually defined very simply as the enduring absence of pulse or respiration. By the 1960s, this definition was in obvious need of an update. A patient who had suffered cardiac arrest might be resuscitated, and in that case, clearly was not “dead.” But a patient with severe head injuries might still retain spontaneous function of heart and lungs, and could be sustained indefinitely, even though the person was not “alive” in the traditional sense.

In August 1968, the Ad Hoc Committee of the Harvard Medical School to Examine the Definition of Brain Death published a report that proposed to define death as a nonreversible absence of brain function.

The next step was to persuade each of the 50 states, and Washington, DC, to add the new definition to their statutes. For this purpose, the National Conference of Commissioners on Uniform State Laws drafted the Uniform Determination of Death Act (UDDA) in 1980. This was approved by the American Medical Association, the American Bar Association, and the

President's Commission on Medical Ethics. These groups recommended that the following wording should be adopted in all jurisdictions in the United States:

An individual who has sustained either (1) irreversible cessation of circulatory and respiratory functions, or (2) irreversible cessation of all functions of the entire brain, including the brain stem, is dead. A determination of death must be made in accordance with accepted medical standards.

By 2011, all states except Arizona had responded by adding at least some provision for brain death. Many used the exact recommended wording, but some decided to make their own modifications. Some samples are shown below. (Information was obtained from Departments of State in 2019.)

**In Alaska, this text is used:**

An individual is considered dead if, in the opinion of a physician licensed or exempt from licensing under AS 08.64 or a registered nurse authorized to pronounce death under AS 08.68.700, based on acceptable medical standards, or in the opinion of a mobile intensive care paramedic, physician assistant, or emergency medical technician authorized to pronounce death based on the medical standards in AS 18.08.089, the individual has sustained irreversible cessation of circulatory and respiratory functions, or irreversible cessation of all functions of the entire brain, including the brain stem. Death may be pronounced in this circumstance before artificial means of maintaining respiratory and cardiac function are terminated.

**In Florida:**

For legal and medical purposes, where respiratory and circulatory functions are maintained by artificial means of support so as to preclude a determination that these functions have ceased, the occurrence of death may be determined where there is the irreversible cessation of the

functioning of the entire brain, including the brain stem, determined in accordance with this section (Fla. Stat. § 382.009[1], [2013]).

**In Virginia:**

In the opinion of a physician, who shall be duly licensed and a specialist in the field of neurology, neurosurgery, electroencephalography, or critical care medicine, when based on the ordinary standards of medical practice, there is the absence of brain stem reflexes, spontaneous brain functions and spontaneous respiratory functions and, in the opinion of such specialist, based on the ordinary standards of medical practice and considering the absence of brain stem reflexes, spontaneous brain functions and spontaneous respiratory functions and the patient's medical record, further attempts at resuscitation or continued supportive maintenance would not be successful in restoring such reflexes or spontaneous functions, and, in such event, death shall be deemed to have occurred at the time when these conditions first coincide. (Va. Code Ann. § 54.1-2972 [2014])

Since the disparity among state regulations seems likely to endure and may even get worse as the issue of death becomes more complex, a cryonics organization cannot make any assumptions about the local definition of legal death when a remote standby is necessary.

*Pronouncement*

The dilemma of a standby team is summarized by two statements:

**Before death has been pronounced, we cannot intervene.**

**Afterward, we should intervene as quickly as possible.**

Unfortunately, regulations about pronouncement vary just as radically as definitions of death. Some states are remarkably permissive: in New York State, for example, according to the Department of Health, “anyone may make the pronouncement of death.” This includes medical technicians, police, firefighters, and other emergency personnel. In practice, however, a private

institution may have its own internal regulations. A hospital may limit the power to a doctor or a nurse—or in some cases, two nurses. The ability to pronounce death may also vary depending on whether death appears to be from natural or unnatural causes.

Keeping track of local differences regarding pronouncement would be impractical for a cryonics organization. Therefore, if a remote standby is being planned, the organization or its standby team leader should try to verify local rules about pronouncement from an authoritative source. This should be done before deployment, if possible.

### *Certification*

Pronouncement is often done verbally. It should not be confused with certification—the signing of a death certificate.

In all states and counties, so far as we can determine, a physician has signing authority. In some states, additionally, a nurse practitioner, forensic pathologist, medical examiner, or coroner may sign. In Texas, a Justice of the Peace may sign. Here again, the organization or team leader should try to perform due diligence to discover local regulations.

## **Cardiopulmonary Support Before Pronouncement**

Determination of death is of special importance when emergency responders such as EMTs or paramedics must decide whether to administer chest compressions. State regulations may compel responders to do CPS unless there is very clear evidence that resuscitation is impossible. California has a particularly rigorous set of guidelines.

To provide some flexibility, a state may allow a paramedic or EMT to declare death, after which there is no further obligation to do CPS, and a cryonics standby team may feel confident to begin work. Bear in mind that emergency responders are almost always in radio contact with supervising staff who may make the actual determination.

Prior to death, from the point of view of a standby team, it may be helpful for responders to continue chest compressions. While the team cannot

request this, they may cite appropriate local regulations that mandate continuation of CPS before pronouncement.

Once again we must emphasize that cryonics team members do not have legal standing to intervene in any way before death has been pronounced, and must refrain from doing so.

## **Elective Cryopreservation**

Since the procedure of cryopreservation would be fatal if it was applied to a living patient, it cannot occur until death has occurred from other causes.

In 1990, Alcor member Thomas Donaldson initiated a legal battle to win the right to be cryopreserved without enduring this waiting period. Donaldson had been diagnosed with a brain tumor in 1988, and wanted the option to be cryopreserved if the tumor grew sufficiently to endanger the integrity of his brain. Donaldson's ultimate purpose as a cryonicist was to extend his life, not to end it, and therefore he felt that he should be able to seek "treatment" at a cryonics organization in the same way that he might seek treatment at a hospital. Since cryonics patients are regarded as legally dead, the judicial relief he sought was authorization to commit suicide with no autopsy or other interference by law enforcement officials after his death, and no prosecution of individuals who might assist him.

In September, 1990 attorney Christopher Ashworth presented Donaldson's case before Santa Barbara Superior Court in California. The case ended up before the California Court of Appeals, which denied the appeal in January 1992. Case details can be read at <http://www.alcor.org/Library/html/donaldson.html>.

Therefore, at this time, elective cryopreservation remains out of the question for human patients.

Thomas Donaldson ultimately succumbed to his cancer naturally in 2006, after which he was cryopreserved by Alcor Foundation. His case was confidential at that time, but has subsequently been acknowledged in a public forum.

## **Medication Before and After Death**

While the Donaldson case affirmed that cryopreservation procedures cannot begin until after legal death has been pronounced, we may speculate that some benign conventional medications could be administered while the patient is still alive, in the hope of enhancing brain preservation after pronouncement. An anticoagulant, for example, would reduce the risk of blood clotting after cardiac arrest. In cryonics, the idea of giving medications before legal death is sometimes referred to as “premedication.”

Premedication cannot be carried out or authorized by a cryonics organization, and team members should never be tempted to intervene in this way, for at least four reasons:

1. Cryopreservation is not a medically recognized form of treatment. Therefore, drugs cannot be legally prescribed for that purpose to a living person.
2. Most standby personnel are not legally qualified to administer medications or treatment.
3. Any interference by standby personnel will almost always conflict with the primary care physician or hospice staff, and at the very least, may result in loss of access to the patient.
4. Standby personnel may be viewed as “waiting for the patient to die,” and any medication administered to a patient or offered to a patient by team members may be misconstrued as an attempt to hasten death.

This last factor is of great importance. Hospice nurses, in particular, may assume that team members are impatient to save time and money by ending a deployment as quickly as possible. In reality, our fundamental motive is to preserve and prolong life, not to abbreviate it, and team members should never say or do anything which creates any other impression.

In some cases, it may be possible to encourage a patient’s physician to give medications (such as an anticoagulant) which may be helpful from our

point of view, but any request of this kind must be made only by the team leader if suitably authorized by the cryonics organization.

Team members may legitimately administer medications after death has been pronounced, because from a legal perspective, the patient no longer has status as a living person and has become a cadaver. In fact cryonics organizations may administer proprietary or experimental medications after pronouncement, and may introduce new procedures or equipment, so long as the treatment is consistent with the contractual agreement that was executed with the member, and so long as there is good reason to believe that innovations will result in improved care.

## **Powers of Attorney and Living Wills**

While the power of a cryonics organization to influence care of a patient before legal death is extremely limited, the patient has two options for influencing that care in ways which may help to lead to a favorable outcome. The options are legal instruments known as “durable power of attorney for health care” and a “living will.”

The concept of power of attorney stretches back into the history of common law (i.e. before legislators began to formulate written statutes). It recognizes that a person has the right to assign some or all of his human rights to another person, who can then act on his behalf, signing documents and even making decisions that have life-and-death implications. Naturally a power of attorney should be granted only with great caution, using a written document that clearly defines the limits of the power.

Power of attorney is automatically nullified if the person who grants it becomes incapacitated by physical injury or mental illness, unless the document specifically states that the power shall endure after incapacitation. This is then known as a “durable power of attorney.” However, even this document will still lapse after legal death.

A durable power of attorney may enable functions such as signing contracts or bank documents, but will not assign power over health-care decisions. For this purpose we must have a “durable power of attorney for health care,” also known as a “durable health care power of attorney.” This



specifically empowers someone to make medical decisions up to and including discontinuation of care if the grantor enters a persistent vegetative state.

In theory, all powers of attorney may be assigned verbally. However, health-care facilities will not recognize durable power of attorney for health care unless it is in written form.

A living will is conceptually very different, because it does not assign powers to any other individual. It simply defines a patient's personal medical preferences.

All states now offer boilerplate legal wording which they regard as acceptable for powers of attorney or living wills. Typically the documents can be downloaded free of charge from web sites maintained by the states. While the wording may vary slightly from one state to another, the basic principles remain the same, and a document executed in one state is likely to be honored if the person who signed it moves to another state.

In Arizona, residents are encouraged to file any durable health care power of attorney document and/or living will with a state-run Advance Health Care Directive Registry, which is accessible on a 24-hour basis. Other states may have similar services, and one of the first steps a cryonics organization should take when mounting a standby is to exercise due diligence to determine whether the patient has recorded any specific instructions for health care or has assigned power of attorney for health care. These documents can have a significant positive or negative affect on the ability of the organization to intervene.

Documents may create problems if they give unclear instructions or have been improperly executed. In particular, anyone who executes such documents should beware of conflicts of interest in the people who witness them. A power of attorney can be judged invalid if it has been witnessed by someone who may benefit from it, and similarly, a health directive that defines the circumstances when life support may be withdrawn may not be valid if it has been countersigned by a relative who is a beneficiary named in the patient's will.

Some people fail to understand these conflicts, and may complete legal documents on a do-it-yourself basis, inappropriately or even incompletely. A

cryonics organization should be alert for problems of this kind. Ideally, if a member of the organization has a terminal condition, the organization should inquire very carefully about any relevant documents.

Some special-interest groups offer guidance to help people through the process of granting powers of attorney or establishing a living will. Aging with Dignity, for example, is a nonprofit organization that sells a document titled “Five Wishes,” which includes warnings regarding common errors and suggestions which a person may find helpful when trying to formulate health-care preferences. The boilerplate text in “Five Wishes” is legally acceptable in 34 states, including Florida, Michigan, and Arizona, where cryonics organizations are currently located.

So long as the legally required wording of a living will remains intact, additional instructions can be added and may be legally binding. For example, a cryonics member can leave directions to minimize the time between the diagnosis of brain death and termination of artificial life support. Alternatively or additionally, a member can instruct medical staff to maintain artificial life support until a cryonics standby team has been deployed at the bedside.

Since no one can imagine and guard against every eventuality, a cryonicist may wish to assign durable power of attorney for health care to someone who is a member of a cryonics organization and can be expected to act as an effective advocate for prompt and effective procedures.

Of course, the choice of a medical surrogate is a matter of personal preference., but regardless of what those preferences may be, we can state unequivocally that they should be written down clearly in an appropriate, legally binding document. We know of numerous tragic cases where cryonicists have trustingly assumed that a spouse or other close relative will fight for their choice to be cryopreserved, yet the next-of-kin have become negligent or actively hostile toward cryonics when the patient is no longer able to speak for himself.

The most powerful way to protect one’s preferences from any future challenge is to make a video stating the desire for cryopreservation, mentioning that this is a carefully considered, rational decision that has not been encouraged or coerced by any third party. A copy of this video should then be placed in the member’s file maintained at the cryonics organization.

Now that digital video is relatively common, a copy can even be uploaded to a web site or cloud storage, allowing it to be accessed from almost anywhere. Unfortunately, very few cryonicists take the trouble to establish such a record.

## **Permission to be Present**

In cases where the cryonics organization receives some warning of impending death and can mount a standby, relatives, doctors, hospital administrators, and others may question the right of personnel to be at or near the bedside. Three situations are possible:

1. If the patient is conscious, coherent, and able to make informed decisions, he or she should be able to obtain permission for team members to be present.
2. If the patient is not conscious or competent, any person who has durable power of attorney for health care should be able to legitimize the presence of team members. If a living will exists, it should request the presence of team members.
3. If neither 1 nor 2 applies, the team leader should be able to present a copy of the patient's sign-up documents and request that medical personnel or family members should honor the patient's wishes. Ideally a patient should have explained his desire for cryonics to his primary care physician at some point in the past. The cryonics organization may even have a document signed by the primary care physician pledging to cooperate, although this is rare.

Based on our knowledge of past cryonics cases, we believe that good personal relations may be more important than legalities, and a cooperative and friendly approach will be more successful than a confrontational or litigious approach. Note also that medical personnel will be more willing to honor a patient's wishes if the wishes seem to be rational. Therefore, the team leader should be ready to provide a general rationale for cryonics, and should explain the need for rapid intervention after pronouncement.

If the team leader lacks medical qualifications, he should be ready to establish telephone contact with a physician or medical advisor who is sympathetic toward cryonics. Experience indicates that a patient's primary care physician or nursing staff can become more receptive to a cryonics team if they receive clarification from a fellow medical professional.

After the team has received permission to be present, the team leader should request rapid pronouncement, should seek permission to deploy equipment as close to the patient as possible, and should ask to perform its initial procedures on-site if possible. In a hospital setting, the team has no clear legal rights in any of these areas, and thus a cooperative personal relationship is all the more important.

We know of a case in which the primary care physician and hospital staff were so hostile toward cryonics, they turned all monitoring devices and screens displaying the patient's vital signs to face the wall, so that team members waiting at the bedside could not see them. Deprived of information, the team members were unable to gauge the patient's condition and the likely time remaining before death. Since the team had no legal recourse to compel the hospital to share information, they simply had to wait, in 12-hour shifts, for a period that lasted more than a week.

## **Funding Issues**

Some cryonics organizations are non-profit entities, but none of them functions as a charitable institution. The organizations that currently maintain cryopreserved patients do not have any obligation to provide free or heavily discounted services. Indeed, by doing so, they would degrade their financial integrity, which would place their existing patients at risk.

Therefore, a standby team will not be deployed unless the organization feels confident that acceptable, legally binding arrangements for funding have been made. While team members should not be directly affected by this consideration, they should be aware that a standby will be contingent on funding, and may be terminated if the organization finds that funding does not exist or has been misrepresented.

Life insurance is the preferred method for a member to fund his own cryopreservation, since the death benefit is usually paid promptly and cannot be contested easily. A will, by comparison, is subject to probate and may be held up by litigation from beneficiaries who are hostile or unsympathetic toward cryonics.

Tensions may occur during a standby when relatives feel that the money paying for cryopreservation would otherwise come to them as a bequest. Team members should be aware of this possibility, should avoid any discussion of financial issues, and should simply state that they are doing their best to honor the wishes that the member affirmed by executing contracts for cryopreservation. *A copy of the documents signed by the member should always be brought to a standby.*

## **Natural and Unnatural Death**

Thus far we have assumed that the cryonics organization may receive some warning when one of its members has a high risk of imminent death. This scenario will give the organization an opportunity to deploy a standby team (if it has this capability), and is likely to result in a determination of natural death.

A discussion of the distinctions between natural and unnatural death will be found in Section 5 of this book, dealing specifically with autopsy.

In this section we will assume that an autopsy is not necessary or can be avoided, allowing the cryonics organization to take possession of the patient in a timely fashion. However, there is a gray area that must be discussed here, which is the situation where a person chooses suicide.

## **Suicide**

Contrary to popular belief, suicide and attempted suicide are not against the law in any of the fifty states. However, suicide is a form of unnatural death, and therefore in most cases will be followed by an autopsy.

The major exception to this rule is where death results from a patient's decision to die solely by refusing food and fluids. If this occurs under medical supervision, an autopsy can be avoided. This option has been chosen

successfully in at least three instances by cryonics patients who felt that it was in their best interests to hasten their demise—for example, to limit the damage from a growing brain tumor. However, the process of death by dehydration is slow and painful, and the patient must be highly motivated to follow it through to the end. It will also be distressing for anyone witnessing its progression.

In any such case, the cryonics organization must tread a difficult path between respecting the right of an individual to choose how to live or how or die, while never actively encouraging, or appearing to encourage, anyone to end life prematurely. Aiding and abetting someone in this way could be construed as assisting suicide.

Assisting suicide is a criminal act in 25 states, according to a survey by the Euthanasia Research & Guidance Organization. In some states, such as California, it is regarded as being little different from homicide. In Michigan, Dr. Jack Kevorkian was convicted of second degree homicide in 1999 and sentenced to 10 to 25 years in prison after he assisted the suicide of a terminally ill patient.

Some states have no specific laws on the subject, but an attorney general may still attempt to prosecute under another statute, especially if a cryonics organization appears to have taken advantage of a naive patient, or has seemed to act recklessly. While most cryonics cases are not significantly profitable, many uninformed people still tend to believe that cryonics is some kind of “scam,” and an attorney general may feel that taking a stand against it will result in favorable media exposure.

Two examples illustrate the caution that has been exercised by organizations attempting to avoid legal liability and conflict of interest.

1. Alcor Foundation reported an incident in the 1990s where a prospective member telephoned the organization repeatedly, claiming to have a terminal condition and threatening to take his own life. Alcor personnel warned him of the risk of autopsy and refused to involve themselves in his plans, especially when they determined that he did not in fact have a serious illness. It transpired that the prospective member had a history of clinical depression, and

ultimately killed himself with a shot to the head, much to the dismay of those who had been trying to advise him.

2. In 2009 the Cryonics Institute reported an incident where a married couple (one of whom claimed to have terminal cancer) expressed an urgent desire to become members. Eventually they admitted that they had made a suicide pact, thinking of cryonics as a “safety net” which would enable them literally to die now and live later. When their plans became apparent, the Cryonics Institute refused to accept their case.

We should add that suicide may have financial implications, since life insurance documents typically allow the company to withhold the death benefit if the client commits suicide within two years after acquiring the insurance. (The exact period may vary.) If a cryonics organization has good reason to believe that a death benefit will be withheld for this reason, the organization may refuse to accept the case.

## **Physician-Assisted Suicide**

Oregon was the first state to establish a law requested by referendum, explicitly permitting physicians to prescribe drugs for purposes of euthanasia, under carefully worded restrictions. The Oregon legislature attempted to overturn the law, but a second referendum reaffirmed it. The U. S. Attorney General, acting on behalf of the George W. Bush administration, attempted to block the law by threatening to withdraw the license of any physician who prescribed a federally controlled drug for purposes of assisted suicide. The U. S. Supreme Court ultimately rejected this attempt and affirmed the legality of the Oregon law, noting in passing that since controlled substances are prescribed for purposes of lethal injection to execute prisoners, it would be inconsistent to prohibit their use for assisted suicide.

Approximately 400 terminal patients in Oregon took advantage of the law during the first decade after it was enacted.

Washington state passed a similar law in November, 2008, as a result of a referendum in which 60 percent of voters approved the measure. In Montana

a judge has ruled that physician-assisted suicide is legal, but at the time of writing his decision is under review by the Montana Supreme Court.

Other states do not have laws that allow physicians to assist in suicide at this time.

Since there is much folklore among cryonicists regarding the Oregon statute, and since the Washington law was modeled on it, we will list the conditions which it imposes:

1. The patient must request the medication verbally on two occasions (separated by at least 15 days), and once in writing.
2. At least two people must witness the requests. Neither of them may be the attending physician. One of them must not be a blood relative or a beneficiary of the estate.
3. The patient must not be diagnosed as suffering any psychological disorder that would cause impaired judgment.
4. The patient must have an Oregon driver's license, ownership of Oregon real estate, Oregon voting registration, or similar evidence of Oregon residency.
5. The patient's physician must explain all reasonable alternatives.
6. A second physician must verify that the patient is terminal, but is mentally capable and acting voluntarily.
7. The patient must take the medication without any outside assistance.
8. Someone must witness the patient taking the medication.

The Oregon statute does not include any requirement regarding autopsy, and a special-interest group in Oregon that advises people on their "right to die" has expressed an opinion that an autopsy may be avoided. No cryonics patient has put this opinion to the test, however.



## **Legal Requirements After Death**

After natural death has been pronounced, or after a coroner or medical examiner releases the patient following an autopsy, typically a funeral director arranges for collection of the body. Where a cryonics organization has been able to deploy its standby team prior to pronouncement, the team itself will usually manage the transfer of the patient. Some states require that this transfer should be under the supervision of a funeral director, who should be present. In other states this is unclear. Many funeral directors employ independently owned services to collect deceased people, but in at least one state we were unable to determine whether such services have to be licensed for this purpose. So far as we are aware, no one has ever challenged the right of a cryonics organization to transport a patient to a mortuary from the place of death.

The funeral director will be responsible for obtaining a signed death certificate from the attending physician and filing it with the nearest office of the state health department. In addition, if the body is to be moved to a different state, the funeral director will usually have to execute and file a transit permit.

Unfortunately these procedures vary widely. California, for example, imposes regulations that can and have caused significant delays, especially when public employees are unavailable to process documents on weekends. Florida, on the other hand, allows a body to be moved out of state immediately, without a death certificate, so long as the certificate follows within a week.

In an effort to avoid the waiting period which can occur as a result of California regulations, patients who have chosen neuropreservation have received surgery at a local facility to remove the cephalon, which has been transported as an anatomical donation while the body has remained in-state.

Team members should be aware that the transport of a whole body from a remote location is usually accomplished using a scheduled airline, which accepts the body as cargo and transports it on a regular passenger jet. Regulations imposed by the Transportation Security Administration have made this significantly more difficult than it used to be, and are going to

restrict the procedure still further. Effective July 1st, 2009, all human remains must originate from a “known shipper.” Each airline must verify the validity of any funeral home that is not already recognized, and a site visit will be required.

We believe that most funeral homes may minimize their paperwork by registering only with one or two airlines. This may restrict the number of flights available for immediate transport of a patient, and may impose delays as a result of suboptimal flight connections. At the time of writing, Suspended Animation, Inc, located in Florida, is pursuing the possibility of registering itself as a “known shipper” even though it is not a funeral home.

The regulations are unlikely to apply to privately rented air ambulances, which are usually available on-demand.

## **Nonmembers, Competence, and Consent**

The above discussions have assumed that the organization is dealing with a member who has completed the usual contractual and financial arrangements for cryopreservation. In some cases, however, the organization may receive a request for cryopreservation from a nonmember, or from someone acting on behalf of a nonmember who is terminally ill or has already been pronounced. In these instances, the organization must consider three basic possibilities:

### *1. The prospective member is able to give informed consent.*

“Informed” is the key word here. Since a person with a terminal illness will not be able to obtain life insurance as a means of paying for cryonics procedures, either an existing life-insurance policy must be revised to name the organization as beneficiary, or a large advance cash payment will be involved. If an existing insurance policy is revised, the current beneficiary may object. If a cash payment is made, relatives and future beneficiaries may object. Either way, friends or relatives may claim that the patient was not mentally competent or was not properly informed about the speculative nature of cryopreservation procedures. They may suspect the cryonics organization of offering false hope and trying to exploit people who are in a frail condition and are frightened by the immediate prospect of death. The cryonics

organization may have to obtain an independent evaluation of the patient's competence to protect itself from allegations of conflict of interest.

*2. The prospective member is not competent or conscious .*

While next-of-kin have the right to establish the means of disposal of human remains, this right may be challenged by other relatives. The case of baseball player Ted Williams was a textbook example of the problems that can occur when heirs of the deceased disagree about cryonics. Even if the cryonics organization can demonstrate that it is legally and ethically entitled to proceed with a case, subsequent disputes can incur high legal expenses and adverse publicity. The imperative to achieve good cryopreservation may motivate an organization to proceed as quickly as possible, but still it must make some effort to find out whether some relatives are strongly opposed to the procedure.

*3. The patient has already legally died.*

A cryonics organization usually will refuse the case unless death has occurred very recently with minimal warm ischemia. The organization may have the legal right to receive the deceased person if suitably authorized to do so, but the procedure of cryopreservation should be justifiable by some rational argument that the brain still contains information of future use or value. See *The Ethics of Non-Ideal Cases*, below.

While team members will not be directly involved with decisions of this type, they may be asked to act in cases where such decisions have been involved. They should be cautious in any situation where informed consent seems doubtful, or hostile family members may try to intervene.

The term "last minute case" is often used in cryonics to describe any case involving a patient who has failed to make cryopreservation arrangements in advance. More specifically, a case in which someone other than the person to be cryopreserved signs paperwork arranging for cryopreservation is called a "third party case." The person to be cryopreserved may already be legally deceased at the time the cryonics organization is contacted. No fixed policy exists regarding such cases, and different

organizations have exercised differing degrees of caution at different times. Alcor has imposed a surcharge on some types of last-minute case in recognition that historically, such cases have had a greater risk of resulting in disputes or litigation. Alcor also imposes a waiting period for standby service after completion of signup documents.

Most inquiries made to cryonics organizations about arranging for cryopreservation of third parties never result in cryopreservation. Factors discouraging an organization from accepting third party cases include:

- Not all family members are receptive to cryonics.
- The person to be cryopreserved has not expressed any prior interest in cryonics.
- Required funds are not immediately available.
- Significant amount of time has passed since legal death.
- Inability to provide informed consent.

Decisions to accept cases may be affected by factors such as compassion, prior personal interactions with the prospective member or next-of-kin, public status of the patient, and a basic desire to “save a life.” Unfortunately these factors have led to some cases that resulted in legal complications.

## **The Ethics of Non-Ideal Cases**

At one extreme, we have the hypothetical “ideal” case where pronouncement occurs within seconds after vital signs cease, and the patient is close to the cryonics facility, so that surgery in preparation for cryoprotective perfusion can begin within an hour after pronouncement.

At the other extreme, we have a relative making a distressed phone call in the hope that a cryonics organization will exhume, retrieve, and cryopreserve a loved one who was buried a week previously.

Clearly the first case involves no ethical problems. If treatment is prompt and effective, we have good reasons to hope for a significant chance of future revival.

Equally clearly, the second case provides virtually no hope at all. Since the mission of a cryonics organization is to preserve a human being with as much fidelity as possible, the organization will betray its own principles and may be accused of offering false hope if it accepts money to cryopreserve a patient whose chances are effectively nil.

Since many cases fall midway between these extremes, how should an organization draw a line between those that are consistent with its mission, and those that are not?

Where a member of the organization has died under non-ideal circumstances, the organization must immediately refer to the member's paperwork, which will include guidance regarding various scenarios. Some members express a strong desire to be cryopreserved under any and all circumstances, no matter how discouraging the situation may be. Others may authorize the organization to "give up" in situations where, for instance, a significant part of the brain has been destroyed by an accident or a tumor. Whatever the member's instructions were, the organization acknowledged and accepted them when it signed the contract, and therefore should be bound by them, even if the procedure seems to have little or no chance of success.

In last-minute cases where a person died before executing a cryonics contract, or is in a comatose state from which he is unlikely to recover, the situation is more difficult. Let us suppose that a close relative provides plausible evidence that the person wanted to be cryopreserved, but never got around to dealing with the documents. Suppose, also, the relative guarantees funding. How should the organization proceed?

No single rule can apply, because circumstances vary so widely. A young patient who was receiving blood thinners before he died of pneumonia (leaving the brain unaffected), and was promptly packed in ice after pronouncement, will be a more promising candidate than an elderly person who has some known impairment from Alzheimer's disease in addition to a history of strokes, and has been allowed to remain at a high room temperature for 12 hours or more.

Cryonics administrators must make decisions on a case-by-case basis that cannot be codified uniformly. If an organization chooses to refuse a case, it may refer a client to another organization which may have different criteria.

## **Case History Involving Legal Issues**

Having discussed various guidelines and generalities, we will now offer a case history to illustrate specifically the legal complexities that can occur. This case also demonstrates the importance of personal factors relative to legal considerations.

A cryonics organization was notified that one of its members had been admitted to a large cancer hospital where he appeared to be in a vegetative state as a result of one or more strokes caused by disseminated intravascular coagulation (DIC). This is a pathological condition in which small clots occur throughout the body.

The patient's brother-in-law had durable power of attorney for health care, and also happened to be a doctor with extensive experience in emergency medicine. He understood and respected the patient's desire for cryopreservation, was cooperative with the cryonics organization, but contrary to all evidence, he refused to accept that the patient was terminal.

The hospital requested an MRI to prove irreversible brain damage, but the brother-in-law refused to permit this, since he rightly believed that the hospital would use it as grounds for disconnecting life support. The patient was receiving platelet transfusions on a daily basis at great expense, and the nursing staff had become generally unsympathetic. The brother-in-law was the only person who held out any hope for the patient's recovery.

The patient happened to be an internationally known figure in his field, and although the hospital was protecting his identity, it might still be leaked to the media, which would take a special interest if the cryonics arrangements became known. Consequently, when the standby team arrived, the team leader was surprised to find his presence requested at a meeting of all the department heads of the hospital.

The hospital administrator fully understood the interests of the cryonicists, and proposed to satisfy them by flying the patient in an air

ambulance to another hospital nearer to the cryonics organization, to minimize transport time after pronouncement. The team leader sensed that the administrator wanted to get rid of a potentially difficult problem, and he expressed doubt that the patient would survive the transfer. The administrator argued persuasively that the transfer would be safe, but still the team leader was reluctant to take responsibility, since all the standby equipment had been flown in and was ready for deployment. The equipment would have to be transported back to the other hospital, which would take at least 24 hours, during which time the patient would not receive prompt attention if he died.

The hospital administrator recognized the team leader's polite but firm intransigence, and retreated to Plan B, which had evidently been discussed previously as a fallback option. He acknowledged an obligation to cooperate with the patient's wishes, and agreed to keep the patient and allow access by the standby team. However, he requested that the team should not deploy equipment until the hospital's legal department had reviewed the patient's signup documents. The team leader agreed, on condition that the legal review would be completed within the next 12 hours. He felt that since the patient was in a stable condition, death was extremely unlikely during that period.

After the meeting, a member of the standby team strongly disagreed with this decision and advocated "suing the hospital." The team leader contacted his superior in the cryonics organization for advice, and was told not to pursue any legal action at that time.

Team members were allowed to remain in a waiting area near the patient, which enabled them to establish contact with nursing staff. Quickly it became clear that the nurses were hostile toward the idea of cryonics. The team leader presented them with a printed booklet explaining the rationale for postmortem stabilization, written for medical professionals. Copies of this booklet circulated among all nursing staff on that floor of the hospital during the next few days.

The hospital honored its pledge to get a rapid reading of the patient's signup documents by its legal department, after which the hospital permitted equipment to be deployed in an empty room near to the patient. Team members began waiting in pairs, on a 12-hour shift basis, while monitoring the

patient's condition. Meanwhile the nursing staff made a gradual transition from being actively unhelpful to being cooperative.

The patient's brother-in-law was now the only remaining impediment to cryonics procedures. He still refused to accept that the patient was terminal, and would not permit disconnection of life support. The hospital responded by entering into a legal battle with the brother-in-law, citing a local statute that gave the hospital the right to seek a court order forcing termination of care in cases of this kind. While the hospital expected to win a favorable judgment, the statute mandated an additional three-week waiting period after the judgment was rendered.

The cryonics organization now found itself in a difficult position, since most of its standby personnel could not remain on-site for more than a few days. Other personnel could be rotated in, but the patient's condition was stable, and three sources of medical advice suggested that the condition would probably remain unchanged until such a time as care was discontinued.

After lengthy discussions, the cryonics organization decided to abandon the standby, temporarily at least, while leaving all the equipment on-site. Since the nursing staff were now actively helpful, the organization felt that the equipment would be secure and the staff could be trusted to give a warning if the patient's condition began to deteriorate. This decision turned out to be correct. A little less than three weeks later, the organization received a call from a nurse stating that death seemed likely. Team members flew back to the hospital, arrived in time for pronouncement, and transported the patient back to the cryonics organization. He was cryopreserved less than 24 hours after pronouncement.

This case is important because it illustrates that a standby can often entail a chain of decisions, any one of which can result in an unfavorable outcome. While legal issues play a part, they may not be the most important part.

## **The Right to be Cryopreserved**

Finally we reach the legal issue which is of most fundamental importance to any organization that maintains and protects patients in a state of



cryopreservation. What legal right does the organization have to take custody of these patients after they have been pronounced, and house them for the indefinite future? We shall address this by beginning with the foundations of law in the United States.

The U. S. Constitution is a document established by “We, the people” to assign specific limited powers to the Federal Government. In other words, power originates with the people, who choose how much of it their government should have. Under the Tenth Amendment, “The powers not delegated to the United States by the Constitution, nor prohibited by it to the States, are reserved to the States respectively, or to the people.”

We may conclude tentatively that if something has not been outlawed, prohibited, or regulated, generally speaking it should be retained by the people by default.

Typically a state law will define various acceptable procedures after death. The usual options are cremation, burial in land, and burial at sea. In addition a state may establish regulations specifying the acceptance of organs or cadavers by hospitals, medical schools, and facilities engaged in research.

The cryopreservation of a whole body or a cephalon, in the hope of revival at some time in the future, clearly is not included in the usual list of options. However, on a constitutional basis we may argue that a procedure should be legal by default if legislators have failed to cite it as being illegal. So long as the procedure doesn’t violate any laws, it should be legal until it is criminalized, and should remain unregulated until legislators choose to regulate it.

The question, then, is whether cryonics procedures are sufficiently similar to other procedures that they can be controlled using existing regulations. This issue has been raised in some states.

In Florida, the Board of Funeral Directors and Embalmers issued a preliminary opinion suggesting that it should have regulatory power over cryopreservation procedures. Seeking advice on this issue, one of the coauthors of this book (Platt) consulted a Florida attorney who happened to have had a previous career as a funeral director. He had provided legal representation to other funeral directors, and had argued cases before the state legislature. Therefore he was ideally suited to give a practical evaluation of

the likely response of the legislature if a cryonics organization argued that it should not be regulated as if it were an embalming facility.

After substantial research, the attorney tentatively concluded that cryoprotective perfusion is sufficiently similar to embalming, the Board of Funeral Directors and Embalmers might receive a favorable judgment from the state if it pursued the matter. On the other hand, since cryoprotective perfusion entails some procedures which are significantly different from embalming, a judgment might go the other way. Realistically, it might depend more on politics than on a strict interpretation of the law. Thus, the procedure was likely to remain in a gray area unless one side or the other pressed to clarify it. "This issue will not be settled until it is heard by a judge," was the final legal advice.

Meanwhile, to receive permission to operate a business in the state of Florida, the cryonics organization had to make a presentation before its local county legislature. The legislature had received a briefing from its attorney, who provided a written opinion stating that there was no statutes to prevent the organization's activities, so long as it followed existing laws to obtain a signed death certificate and a transit permit for human remains that were moved out-of-state. With some reluctance, the legislature voted to permit the operation of the cryonics facility, without seeking any specific regulations applying to cryonics.

In 2004, after Alcor Foundation had received a lot of adverse publicity relating to the Ted Williams case, an Arizona state legislator introduced a bill that would have empowered the local Board of Funeral Directors and Embalmers to regulate cryonics. The text of this bill may be found here: <http://www.alcor.org/Library/html/legislation.html>. The law that it created would have been onerous, since it would have required (among other provisions) that only a licensed embalmer could perform procedures to prepare a patient for cryopreservation. Eventually the bill was withdrawn, and Alcor remains unregulated by default. Of course, it must still conform with regulations (such as building and safety codes) that are not specific to cryonics but apply to all businesses in its location, and must still insure that death certificates, transit permits, and other appropriate paperwork are executed for the patients it receives.

In Michigan, the Cryonics Institute is now regulated as a cemetery by the Department of Consumer and Industry Services. Some special provisions were included in an agreement with the regulatory agency, but since it is now classified as a cemetery, CI cannot legally perform any surgical procedures or perfusion on its premises, and must instead use a prep room owned by a local funeral director. Since CI has never maintained its own standby, stabilization, and transport services, these procedures were never a legal issue.

Possibly the most famous and potentially damaging legal problems in the history of cryonics arose in December, 1987, when a coroner became concerned that a patient named Dora Kent had died inside Alcor's facility, which was then located in Riverside, California. Since the patient had made arrangements for neuropreservation only, the body was available for autopsy.

Alcor informed the coroner's office about the medications that had been administered after legal death as a standard part of cryonics procedures. In 1987, those medications included barbiturates which were administered for the dual purpose of lowering metabolic requirements of the brain and avoiding any risk of resumption of consciousness during cardiopulmonary support.

The coroner initially found pneumonia as the cause of death. Unfortunately the coroner came to suspect that barbiturates had been administered to hasten death, and demanded to autopsy Dora Kent's brain. It was not understood by the coroner's office that the application of prolonged cardiopulmonary support after death invalidates forensic tests that would normally determine whether a drug was administered before or after death. Alcor successfully obtained a restraining order to prevent autopsy of the brain of Dora Kent or any other Alcor patients.

Detailed discussion of the case is available and may be found at <http://www.alcor.org/Library/html/DoraKentCase.html>.

Subsequently the California Department of Health Services (DHS) stopped issuing disposition permits for new whole-body cryonics patients in California, saying that cryonics was not listed as an option on the standard disposition permit. Alcor sued the DHS on behalf of a patient seeking a disposition permit, and won a trial court ruling in October, 1990. See <http://www.alcor.org/Library/pdfs/RoeVMitchellOrder25Oct1990.pdf>. The DHS appealed, leading to a California Court of Appeals against the DHS in

June, 1992. The text of this judgment may be found here:

<http://www.alcor.org/Library/html/CaliforniaAppellateCourtDecison.html>.

This of case raised the fundamental issue of whether a list of entities authorized to receive human remains should be regarded as complete and all-inclusive, or should allow the existence of other entities that have not yet been recognized by regulators. Courts chose the latter interpretation, and following this decision, cryonics became a legally sanctioned option for disposition of human remains in California.

We conclude from these cases and opinions that with the exception of the Cryonics Institute in Michigan, the procedures described in this handbook remain unregulated by default, so long as they do not violate existing laws. If cryonics becomes a more popular option in future decades, we may see legislators and regulators taking a greater interest in it. At that time, organizations may need to establish standard operating procedures on a jointly agreed basis, in an effort to receive regulation which is appropriate and not unduly onerous.

## **The Uniform Anatomical Gift Act**

The Uniform Anatomical Gift Act (UAGA) was drafted by the NCCUSL, the same organization that established the Uniform Determination of Death Act. The UAGA was created in 1968, and was quickly enacted by all states. The wording of the act was revised in 1987, but only 26 states formally adopted the revised version, and many states subsequently made their own revisions, so that the UAGA was not actually uniform anymore.

In 2006 the NCCUSL drafted a new UAGA in another attempt to persuade states to cooperate on uniform wording. As of mid-2009 the 2006 version of the law had been enacted or introduced in all states except the following: Nebraska, Louisiana, South Carolina, Maryland, Delaware, Pennsylvania, New York, New Hampshire, Vermont, Massachusetts, and Rhode Island. We conclude that if a team is called to a case in the western half of the nation, its chances of being in an area covered by the current version of the UAGA are excellent. On the East Coast, the situation is less clear.

The original purpose of the UAGA was to create a legal mechanism by which living people could authorize (or prohibit) the donation of their organs after death. Prior to 1968, organ donation was not legally recognized in the United States. (The first successful heart transplant was performed in November, 1967.) The UAGA also forbids the selling of organs and allows them only to be donated as a gift, as its name implies.

Since the human brain is undoubtedly an organ, cryonics organizations view the UAGA as an important legal means to enforce the wishes of a person who has chosen to be cryopreserved. All cryonics organizations ask applicants to execute a UAGA donor form as a condition of membership. All hospitals and hospices are familiar with a UAGA form and are thus motivated to comply with the wishes of the donor, especially since the UAGA provides them with some immunity from liability if they do so.

Under the current version of the act, the following classes of people are empowered to authorize (or prohibit) a donation after death, while the donor is still alive:

1. The donor, if the donor is an adult or is a minor and is a) emancipated or b) old enough to apply for a driver's license in the state of residence.
2. Anyone to whom the donor has granted durable power of attorney for health Care.
3. A parent or guardian, if the donor is an unemancipated minor.

The preference of any member of a class higher up the list will override the preferences of members of classes farther down the list.

The wording here has been simplified. See [www.anatomicalgiftact.org](http://www.anatomicalgiftact.org) for the exact wording.

Under the current version of the act, the following classes of people are empowered to authorize (or prohibit) a donation on behalf of a patient who has already died without making his own donor arrangements:

1. Anyone who would have had this power before the donor's death.
2. The spouse of the donor.

3. Adult children of the donor.
4. Parents of the donor.
5. Adult siblings of the donor.
6. Adult grandchildren of the donor.
7. Grandparents of the decedent;
8. Any adult who “exhibited special care and concern” for the donor.
9. Persons who were guardians of the donor at the time of death.
10. Any other person having the authority to dispose of the donor’s body.

The preference of any member of a class higher up the list will override the preferences of members of classes farther down the list.

If there is more than one person in a class empowered to authorize a donation, and anyone in that class objects, the donation can be made only if a majority of members of the class who are “reasonably available” will authorize it.

The wording here has been simplified. See [www.anatomicalgiftact.org](http://www.anatomicalgiftact.org) for the exact wording.

From this you may infer that the UAGA is heavily biased toward facilitating organ donation, since anyone who has “exhibited special care and concern” can authorize it. However, the same classes of people who can authorize it are also empowered to prohibit it, and if the spouse of someone who has died is opposed to the idea, no other living person can override the spouse’s decision. Clearly it is in the interests of anyone who wishes to be cryopreserved to execute an Anatomical Gift form so that a challenge of this kind becomes impossible.

We conclude that the UAGA can be used as a legal instrument to enforce a person’s desire to donate himself for cryopreservation. But who is empowered to *accept* a donation?

Section 11 of the current version of the act provides this list of persons who can be “named in the document of gift”:

1. A hospital; accredited medical school, dental school, college, or university; organ procurement organization; or other appropriate person, for research or education.
2. A person designated by the donor as a recipient, unless the recipient is unable to receive the donated organ.
3. An eye bank or tissue bank.

The above wording has been simplified. See [www.anatomicalgiftact.org](http://www.anatomicalgiftact.org) for the exact wording.

We believe that the drafters of the UAGA were particularly concerned with eliminating any trade in organs for financial gain. Hence the provision in clause 1, above, that the received organ must be used for “research or education” if the organization is not a hospital, medical or dental school, university, or organ procurement organization.

At the same time, the drafters of the UAGA would not want to eliminate any deserving organization by error, and thus they authorized any “appropriate person” to receive donated organs, so long as the purpose is for research or education.

A cryonics organization is obviously appropriate to receive a donation from a member who has made arrangements for cryopreservation. The only question, then, is whether a cryonics organization can reasonably claim to be engaged in research or education. Since cryonics is a procedure that is still under development, any cryonics case should be considered a form of research, so long as it is pursued in a way which is consistent with research. In other words, data should be collected, and the case should be assessed in an effort to draw conclusions and improve the outcome of future cases. If cryonics cases are performed with reasonable diligence, this is exactly how they should be done.

What about the caregivers who do the hands-on work to make a donation possible? Team members will be reassured to know that the UAGA protects anyone who is acting in accordance with its provisions and with the wishes of a patient who has executed a donor form. The current version of the act states:

- A person that acts in accordance with this [act] or with the applicable anatomical gift law of another state, or attempts in good faith to do so, is not liable for the act in a civil action, criminal prosecution, or administrative proceeding.
- Neither the person making an anatomical gift nor the donor's estate is liable for any injury or damage that results from the making or use of the gift.

The conclusion here is very important. According to our interpretation:

- The UAGA is appropriate for any person who wishes to donate his whole body, or just the head and brain, for cryopreservation after death.
- The UAGA can empower a cryonics organization to receive such a donation.
- The UAGA can protect team members from all forms of liability if they act in good faith to promote the cryopreservation of a patient who has executed a donor form.

We must add as a caveat that to the best of our knowledge, no test case has yet affirmed the applicability of the UAGA to cryonics cases in a court of law. However, when the Arizona legislature was considering a bill to regulate cryonics, one of the provisions of the bill was that cryonics organizations in Arizona would not be eligible for anatomical donations. This strongly suggests that the Arizona senator who introduced the bill recognized the legitimate application of the UAGA to cryonics. If he had not, he would have seen little reason to eliminate it.

## **Custody of Remains**

In addition to the UAGA, state laws typically allow a relative to make a binding decision naming the organization or method which will determine custody of human remains. In California the applicable law states: "The right to control the disposition of the remains of a deceased person, including the



location and conditions of interment, unless other directions have been given by the decedent, vests in . . . the following in the order named.” A hierarchical list of relatives then follows.

Other states have similar laws recognizing the right of a patient or his relatives to make a binding decision on his subsequent fate, whether it is to be burial, cremation, or cryonics.

Note that the statute quoted above does not give any organization the right to own human remains. Likewise, the UAGA does not allow ownership of people who are deceased, or the organs which they contain. This is a very important principle:

Under United States law, human remains shall not have monetary value, and *cannot be owned as property*.

Because cryonics patients cannot be owned, they cannot be defended by laws relating to property. Therefore, relatives of a deceased person may petition a court to have the person returned to them, much as a parent may petition a court to take custody of a child. A relative may claim that the preserved patient “never actually wanted to be frozen” and only ended up in that state because another relative made a plausible claim that it was what he wanted.

One of the many hazards of last-minute cases is that the patient’s wishes may be unrecorded, and relatives will be the only source of information. Under stressful conditions where time is of the essence, an organization may have difficulty polling all interested parties and reaching a clear opinion regarding the wishes of the person who has died.

In a few cases, relatives have proved that a loved one had no interest in cryonics, and a judge has directed that the cryonics organization should surrender the patient. More often, the organization has been able to present plausible proof that the patient did want to be preserved, and relatives have been unsuccessful in their claim.

## **General Issues of Legal Liability**

Having digressed into many different legal aspects of case work and cryopreservation, we will complete this section by offering a summary of

general principles which are most likely to be of direct relevance to personnel engaged in standby, stabilization, and transport duties. The key principle is that of liability.

All of us incur liability if our actions cause harm or financial loss to a person, or to a group of people, or to an organization. If the liability is proved in a civil action, we may have to pay damages as compensation to the injured party.

We also incur liability if we violate the law, in which case we become vulnerable to criminal penalties imposed by a county, state, or federal jurisdiction.

A cryonics organization can protect team members from civil liability, but cannot protect team members from criminal liability.

The civil-law protection that a team member receives will depend on any written agreement that exists between the team member and the organization. Throughout most of the history of cryonics, nonemployee standby team members were volunteers who were uncompensated and unprotected by any written agreement. We find it encouraging that during this time, so far as we are aware, no individual was ever named in a civil suit as a result of actions performed during standby, stabilization, or transport work.

More recently, efforts have been made to establish contracts which protect team members who are not employees. Typically, a cryonics organization will assume responsibility for the actions of its team members so long as they follow instructions, act in good faith, and behave reasonably. The precise rights and liabilities of team members will depend on their status as employees or independent contractors, the exact wording of their agreement with the organization, and local statutes where the organization is based and where duties are performed.

Still, we can offer some guidelines which should be followed in order to minimize the risks of liability. If team members go beyond these guidelines, they may open themselves or their organization to civil liability. In some instances they may also be violating criminal law.

- Do not interfere with medical procedures in any way, prior to pronouncement of legal death.

- Do not touch a living patient or administer any medical intervention or treatment. Technically, even the application of a finger pulse oximeter constitutes a medical procedure.
- If you have no medical qualifications, never impersonate a medically qualified person or allow others to assume that you are qualified. Always be careful to establish your exact status.
- Never make assurances or promises to family members, friends, or others close to the patient.
- Do not make any statements to news media unless you have been authorized to do so.
- Avoid any confrontations or threats of confrontations. Even a joking remark can be interpreted as being confrontational under stressful situations.
- Do not sign any documents relating to the standby or transport of a patient unless you are sure that you have been given authority to do so. In that case, make it clear that you are signing on behalf of the cryonics organization, not on your own behalf.
- If you are in doubt about any action, ask advice first.
- Be especially careful regarding regulations restricting transport of human remains across county or state lines.

In addition to these specific guidelines, we can also suggest some general principles that should help to minimize the risk of errors that create legal liability. In particular, we believe that a team member or team leader engaged in standby, stabilization, and transport work should recognize a chain of command. Typically, such a chain would look like this:

1. Directors of the organization
2. CEO or President of the organization
3. Standby-Transport Administrator (or similar title)

4. Team Leader

5. Team Member

A medical consultant may also have some authority during a case. Whether this exceeds the authority of a Standby-Transport Administrator may vary.

If a team member or team member must exercise initiative in the absence of instructions or guidance, decisions should be made with awareness of these general principles:

1. The first priority should be to avoid doing anything that will endanger a cryonics organization and its ability to protect existing patients who have been cryopreserved. In the future, standby-transport work may be performed more by independent organizations. In this scenario, an error during standby-transport may incur liability only for the local organization. CryoCare Foundation pioneered this model, using BioPreservation, Inc. as its standby-transport service provider. More recently, Suspended Animation, Inc. has provided independently owned service for Alcor and for the Cryonics Institute.
2. The second priority (which should be consistent with the first) is to remain within all known limits of the law. Of course, not all laws are equal; a team member may choose to exceed the speed limit when transporting a patient to the airport, but should never violate regulations regarding death certificates or transit permits.
3. Team members should honor the contractual agreement between the patient and the cryonics organization. Technically the provisions of this agreement are not binding after the death of the person who signed it, but still, they should be recognized.
4. Lastly, the team should avoid any action that might provoke legal conflict with family members, friends of the patient, or entities such as hospitals, hospices, or funeral homes.

## **Addendum: Legal Aspects of Animal Research in Cryonics**

Some observers have questioned whether animal research is legally or ethically justifiable when its objective is to improve procedures for human cryopreservation.

Under the provisions of the Animal Welfare Act and the National Institutes of Health's (NIH) "Guide for the Care and Use of Laboratory Animals" (the Guide), any procedure can be performed on an animal if it can be successfully argued that it is scientifically justified. The process of justification of any particular procedure involves the submission of a protocol outlining the experiment or procedure to the institution's Institutional Animal Care and Use Committee (IACUC), an internal committee composed of a veterinarian, scientist experienced in animal use, and members of the community with particular qualifications. The IACUC must ensure that alternatives to animal use have been considered, that the experiments are not unnecessarily duplicative, and that pain relief is provided unless it would compromise the results of the study.

Regulation of animal use for scientific purposes varies by species and by regulatory agency. The United States Department of Agriculture (USDA) enforces the Animal Welfare Act and regulates the use of all vertebrates except for purpose-bred rodents and birds. However, these animals are equally regulated under Public Health Service (PHS) regulations, which are enforced by the Office of Laboratory Animal Welfare. All animal research programs fall under USDA regulation, while only those receiving federal funds fall under PHS regulation.

Use of animals for cryonics research or stabilization training purposes frequently falls into a "gray area" when viewed from an outside perspective. It is therefore advisable that any research or training program making use of regulated animals meet all applicable regulatory standards and that internal controls be put in place to ensure compliance. This requires the establishment of a functional IACUC to review all protocols and to conduct regular animal care facility inspections. A good working relationship with the USDA inspector should also be nurtured and maintained.

Importantly, it should not be assumed that the use of regulated animals at another institution does not require the same compliance as any project taking place “in-house.” Again, the importance of a working and well-trained IACUC cannot be stressed enough, since they will deal with such matters on a case-by-case basis and determine the best course of action in compliance with the appropriate governing regulations and in collaboration with the appropriate officials.

### **Sample Documents**

Samples of documents relevant to the issues discussed will be found in the remaining pages.

**STATE OF ARIZONA**  
**PREHOSPITAL MEDICAL CARE DIRECTIVE (DO NOT RESUSCITATE)**  
**(IMPORTANT—THIS DOCUMENT MUST BE ON PAPER WITH ORANGE BACKGROUND)**

**GENERAL INFORMATION AND INSTRUCTIONS:** A Prehospital Medical Care Directive is a document signed by you and your doctor that informs emergency medical technicians (EMTs) or hospital emergency personnel not to resuscitate you. Sometimes this is called a DNR – Do Not Resuscitate. If you have this form, EMTs and other emergency personnel will not use equipment, drugs, or devices to restart your heart or breathing, but they will not withhold medical interventions that are necessary to provide comfort care or to alleviate pain. **IMPORTANT:** Under Arizona law a Prehospital Medical Care Directive or DNR must be on letter sized paper or wallet sized paper on an orange background to be valid.

You can either attach a picture to this form, or complete the personal information. You must also complete the form and sign it in front of a witness. Your health care provider and your witness must sign this form.

**1. My Directive and My Signature:**

**In the event of cardiac or respiratory arrest, I refuse any resuscitation measures including cardiac compression, endotracheal intubation and other advanced airway management, artificial ventilation, defibrillation, administration of advanced cardiac life support drugs and related emergency medical procedures.**

Patient (Signature or Mark): \_\_\_\_\_ Date: \_\_\_\_\_

**PROVIDE THE FOLLOWING INFORMATION:**

**OR**

**ATTACH RECENT PHOTOGRAPH HERE:**

My Date of Birth \_\_\_\_\_  
My Sex \_\_\_\_\_  
My Race \_\_\_\_\_  
My Eye Color \_\_\_\_\_  
My Hair Color \_\_\_\_\_

**HERE**

**2. Information About My Doctor and Hospice (if I am in Hospice):**

Physician: \_\_\_\_\_ Telephone: \_\_\_\_\_

Hospice Program, if applicable (name): \_\_\_\_\_

**3. Signature of Doctor or Other Health Care Provider:**

I have explained this form and its consequences to the signer and obtained assurance that the signer understands that death may result from any refused care listed above.

Signature of Licensed Health Care Provider: \_\_\_\_\_ Date: \_\_\_\_\_

**4. Signature of Witness to My Directive:**

I was present when this form was signed (or marked). The patient then appeared to be of sound mind and free from duress.

Signature: \_\_\_\_\_ Date: \_\_\_\_\_

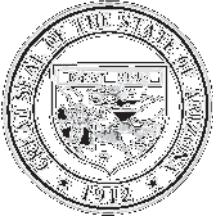

**KEN BENNETT**  
**SECRETARY OF STATE**  
**STATE OF ARIZONA**



Greetings from Secretary Ken Bennett:

The Arizona State Legislature created the Arizona Advance Health Care Directive Registry in May 2004. The Registry is a database for the storage of advance directives and the Arizona Secretary of State oversees its security and operations.

The Arizona Secretary of State's Office is pleased to provide you with this safe and confidential place to store your advance directive (Living Will, Medical Power of Attorney and Mental Power of Attorney).

Less than 25 percent of Americans have expressed their thoughts in writing about how they wish to be cared for at the end of life. Most people avoid the subject. Planning ahead by completing an advance directive helps you make thoughtful choices about your future care and will ease the stress on your family and loved ones. Congratulations on taking the first step by completing an advance directive document.

In order to honor an advance directive, your physician and healthcare institution must be aware of what it says. Arizona's Advance Health Care Directive Registry is a way for your advance directive to be available where and when it is needed. Through your password, you decide who can read your directive that is stored in the Registry.

The most important thing you can do to ensure that the health care decisions you have made in advance are followed is to talk about them. Talk to your family, friends, neighbors, clergy, doctors and other health care providers. Let them know what you do and do not want when you cannot speak for yourself. Store a copy of your advance directive in Arizona's Advance Health Care Directive Registry so it is available in an emergency.

Thank you for your interest in Arizona's Advance Health Care Directive Registry. If you have further questions about filing your directive, please refer my website at [www.azsos.gov](http://www.azsos.gov) under the Advance Directive section or call (602) 542-6187 or toll-free at 1-877-458-5842 at your convenience.

Best Wishes,

A handwritten signature in black ink that reads "Ken Bennett".

Ken Bennett  
Secretary of State





# Your Guide to filing Advance Directives

Secretary  
of State



SERVICES

Our staff is available 8 a.m. to 5 p.m. Monday through Friday except state holidays to answer questions about filing your advance directive with our office. Call (602) 542-6187.

Instructions on how to file and forms are included with this information.

We cannot assist you in the preparation of an advance directive, this can be done on your own by:

- accessing the samples in Arizona law;
- by contacting organizations that specialize in advance directives; or
- by having an attorney prepare the document for you.

## Arizonans Can File Advance Directives

Arizonans can file their health care directives in a secure and confidential Advance Directive Registry at the Arizona Secretary of State's Office.

In order to file an advance directive you first need to prepare a directive if you haven't already done so.

See page 2 on preparation and filing requirements.



*Prepare an advance directive if you do not have one. Samples are provided in Arizona law, or contact an attorney to help you prepare one.*

## The Advance Directive Registry is Unique

*Anytime, Anyplace, and Always Available*

In order to honor an advance directive, your agent, physician, hospital or nursing home must be aware of it and what it says.

The Arizona Advance Directive Registry is a place to electronically store a copy of your advance directive so it will be available where and when it is needed 24/7. Access to our central database via computer helps expedite patient's health requests.

The Arizona Advance Directive Registry also empowers you and lets you decide who will be able to review your advance directive.

The Secretary of State's Registry is maintained and operated by the Secretary of State's Office under Arizona law.



*Your directive is available day or night — piece of mind for your family, friends and loved ones.*

## About Our Service ★ File Your Directive, Access Your Directive

The Arizona Advance Directive Registry is more than just a place to store your advance directive – it is a virtual file cabinet that holds your advance directive – so that it is available when needed.

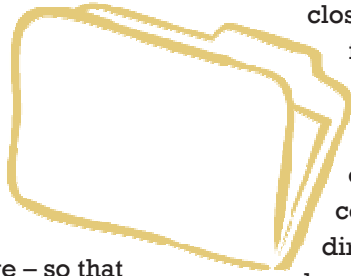

close family member or friend, your doctor or clinic.

Anyone in any state or country can have access to your advance directive as long as they have access to a computer.

As long as you can speak for yourself, you are in charge of your decisions.

If you wish to change your advance directive simply complete a new one and make sure it is dated.

The advance directive with the most recent date is the one that will be followed.

### A Free Service at no Cost to You

There is no fee to store an advance directive in the Registry. Once registered you will receive a Registry card with an identification number and a password.

### You Are In Control

The best part about the Registry is that *you* decide who has access to your health care directive.

You can share the password with your health care (medical) power of attorney, designated agent, to a

In the event of an emergency the Registry card can be kept in a wallet to let your wishes be known if you are unable to communicate to a doctor or health care provider.

### Take Charge of Your Decisions

You can always change your mind and change your advance directive at any time.

You just need to tell your doctor or to the medical team taking care of you.



Remember to send the new advance directive to update the Registry as soon as you can, so that it can replace the old one on file. See the

instructions on page 3 on how to re-file with us.

## Get Started ★ Prepare an Advance Directive

### Choose and Prepare an Advance Directive to File

Our office cannot answer legal questions about how to prepare advance directives.

We are merely the filing office for the Registry. Samples of directives are provided in Arizona law

(see gray box to the right).

If you do not feel comfortable in preparing an advance directive by yourself we encourage you to contact an attorney or one of the

many organizations that provide this type of service.

### Types of Directives that Can Be Submitted For Registry Inclusion

The advance directives defined in Arizona law are included in the Registry as they have legal status.

Only directives that concern your future health care and health care choices are included in the Registry.

### Documents Ineligible for Inclusion in the Advance Directive Registry

Financial documents such as Last Will & Testaments, or Living Trusts are ineligible for submission into the Registry.

### Arizona State Law Defines Advance Directives

Directives Include:

- Health Care (Medical) Power of Attorney A.R.S. § 36-3224
- Mental Health Care Power of Attorney A.R.S. § 36-3286
- Living Will A.R.S. § 36-3262

Sample of these directives are in the referenced statutes above and can be found online at [www.azleg.gov](http://www.azleg.gov).

Pre-Hospital Medical Care Directives, also known as the Orange form or Orange card, are also ineligible.



# Get Started ★ File Your Advance Directive in the Registry

## Instructions for the SOS Registration Agreement

Read the instructions on the Registration Agreement included with this guide and fill in all the blank spaces on both sides. Sign and date it.

If you have any questions about registration of your advance directive, call Business Services at (602) 542-6187; or Toll Free at (800) 458-5842.

## Submit the Form and Directive to the Office for Processing



Attach a copy of your advance directive to your completed Registration Agreement.

The copy of your advance directive must be legible and clear. **Do not send your original advance directive forms.**

Submit in person or by mail to:  
 Arizona Advance Directive Registry  
 Arizona Secretary of State  
 1700 W. Washington Street, 7th Fl.

Phoenix, AZ 85007

The office does not accept electronic filings of these documents.

## Our Checks and Balance System

Once your advance directive is processed, you will be asked to verify your file for accuracy.

It only becomes activated upon notification from you that the information filed is accurate.

When the printed record of the registration is returned by mail, review it.

Check the appropriate box marking either “no corrections required” or “the information is not correct.”

Sign the form and return it to the Secretary of State’s Office.

## Registration and Activation of Your Directive

The Secretary of State’s Office will activate your registration when a verification

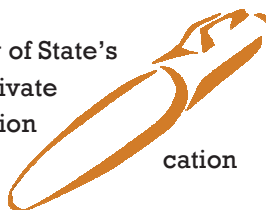

form marked “no corrections required” is returned and signed.

Only then will the Registry wallet card and password be issued to you.



## Receipt of the Registry Wallet Card

Keep the wallet card with your file number and password handy.

As stated on page 2, trust your password only to close family members, friends and physicians.

If you designate someone as your agent in an advance directive on file at the Secretary of State make sure to give them copy of the information provided on your Registry wallet card.

Also provide the information on how to access your directive included below.

## Updating An Advance Directive

The process is the same if you are changing an advance directive already on file.

Simply fill out a new two-page Registration Agreement and send the new directive to us.

## How to Access Your Directive in the Registry

Go to [www.azsos.gov](http://www.azsos.gov)

Click on the “Advance Directives Link”



Click on “View Your Advance Directive”

You will be re-directed to the login page. Use your User ID and Password on your Registry Wallet Card.

A “Welcome” screen appears. On this page you can view your directive and view your contact information. When done, log out.

**How secure is secure?**  
 This Web page is encrypted. Information exchanged with any address beginning with https is encrypted using SSL before transmission.

**For more info  
contact  
ad@azsos.gov**



## **Arizona Advance Directive Registry**

**Enclosed is the information you requested from the  
Arizona Secretary of State's Office about  
The Arizona Advance Directive Registry**



ARIZONA ADVANCE DIRECTIVE REGISTRY

**The Honorable KEN BENNETT**

Secretary of State

1700 W. Washington Street, 7th Floor

Phoenix, AZ 85007

[www.azsos.gov](http://www.azsos.gov)

(602) 542-4285



**Arizona Health Care Directives Registry**  
**ARIZONA SECRETARY OF STATE**

1700 W. Washington Street, 7th Floor, Phoenix, AZ 85007-2888  
(602) 542-6187  
(800) 458-5842 (within Arizona)  
Website: www.azsos.gov

FOR OFFICE USE ONLY

**REGISTRATION AGREEMENT**

**About this agreement:**

This agreement shall be used for the registration of a Health Care Directive in the State of Arizona under the authority of A.R.S. § 36-3291 - 3297

This form/agreement must be written legibly or computer generated. For your convenience, this form has been designed to be filled out and printed online at the website referenced above.

**Fees:** None

**Processing time-frame:** three weeks

**How to complete this form:**

- Read this agreement carefully, and fill in all blank spaces
- Attach a copy of your witnessed or notarized Health Care Directive to this Agreement
- DO NOT send your original Health Care Directive Form
- Sign and date this Agreement
- Return by mail or in person to:  
Arizona Secretary of State Dept A  
1700 W. Washington Street, 7th Fl.  
Phoenix, Arizona 85007  
Walk-in service: 14 N. 18th Ave., Phoenix, Arizona  
Tucson Office: 400 W. Congress, Ste. 252

Last Name		First Name		Middle Name	
Address					
City		State		Zip	
Phone		Birth Date (month/day/year)		Last 4 digits of Social Security Number	
Printed name as you want it listed on your membership card					
Address to return documents and wallet card (IF DIFFERENT FROM ADDRESS ABOVE)					
Name					
Address					
City		State		Zip	
I want to: <input type="checkbox"/> Store a health care directive(s) in the Registry <input type="checkbox"/> Replace a health care directive(s) now in the Registry with a new one <input type="checkbox"/> Add an additional document to my currently stored directive(s) <input type="checkbox"/> Remove my health care directive(s) from the Registry <input type="checkbox"/> Request a replacement wallet card (no change to health care directive(s) in Registry) <input type="checkbox"/> Change Registration Agreement information (such as new a address)					

**You must complete and sign the Agreement on Page 2 of this form.**



AD0001



**Arizona Health Care Directives Registry**  
**ARIZONA SECRETARY OF STATE**

1700 W. Washington Street, 7th Floor, Phoenix, AZ 85007-2888  
(602) 542-6187  
(800) 458-5842 (within Arizona)  
Website: [www.azsos.gov](http://www.azsos.gov)

FOR OFFICE USE ONLY

**REGISTRATION AGREEMENT**

I am providing this personal information, along with a copy of my advance directive, with the understanding that this information will be stored in the Arizona Health Care Directive Registry. I certify that the advance directive that accompanies this Agreement is my currently effective advance directive, and was duly executed, witnessed and acknowledged in accordance with the laws of the State of Arizona.

I understand this authorization is voluntary. This authorization to store my advance directive in the Arizona Health Care Directives Registry will remain in force until revoked by me. I understand that I may revoke this authorization at any time by giving written notice of my revocation to the Contact Office listed below. I understand that revocation of this authorization will NOT affect any action you took in reliance on this authorization before you received my written notice of revocation.

**Contact Office:** Office of the Arizona Secretary of State Dept A  
**Telephone:** 602-542-6187    **E-mail:** [AD@azsos.gov](mailto:AD@azsos.gov)  
**Address:** 1700 W. Washington Street, 7th Floor, Phoenix, AZ, 85007

Your registration form will be processed within three (3) weeks. You will receive further information in the mail. In order to complete the registration of your health care directive(s) you are required to reply to the letter that you will receive.

For further assistance please contact the Arizona Secretary of State at (602) 542-6187 or visit us online at: [www.azsos.gov](http://www.azsos.gov)

Signature of person completing this agreement	Date
Printed Name	



AD0002

## Instructions for Completing the Health Care Directive

1. Print your name on the first blank line. "I, MY NAME, want everyone who cares for me to know what health care I want when I cannot let others know what I want."
2. Think about the statement, "A quality of life that is unacceptable to me means" and check each item from the list below that applies.

This means that if you are in the condition described, you would want your family and doctors to stop or withdraw treatment. You would not want to continue to live in that condition.

You may add any words you want on the blank lines to further describe the conditions when you would not want to continue to receive treatment. You may cross out anything on this form that you do not want or do not agree with.

3. Think about the statement, "There are some procedures that I do not want under any circumstances."

If you have decided that you would never want a treatment listed, check that box. If you have not decided yet, or if you would want your doctor to try these treatments, leave the box blank.

4. Think about the statement, "When I am near death, it is important to me that." You can write anything you like on these lines. Some people say, "I want hospice care.", "I want to die at home.", or "I want my family near me." You may leave these lines blank if you wish.

5. You must sign this form on the reverse side and you must have your signature witnessed.

The witness cannot be related to you by blood, marriage or adoption, cannot be a beneficiary to your estate, and cannot be directly involved in your healthcare.

In Arizona, it is not necessary to have this form notarized, but there is a space for a notary if you desire.

6. Give a copy of your Health Care Directive to your Health Care (Medical) Power of Attorney, to your family and close friends, and to your doctor. Keep a copy to take to the hospital or clinic if you become ill and need treatment.

**Instructions for Completing the Health Care (Medical) Power of Attorney  
with Mental Health Authority**

1. Print your name in the first blank line.

"I, MY NAME, as principal, designate . . ."

2. Print the name of the person you have chosen to be your Health Care (Medical) Power of Attorney on the next blank line.

"OTHER PERSON'S NAME, as my agent for all matters relating to my health care ..."

3. Print the address and phone number of the person you have chosen to be your Health Care (Medical) Power of Attorney on the next blank line.

"Print agent ADDRESS and PHONE"

4. You may name an alternate person to be your Health Care (Medical) Power of Attorney. This second person would take over if the first person you named is not available or is unable to make decisions for you.

"If my agent is unwilling or unable to serve or continue to serve, I hereby appoint SECOND PERSON'S NAME as my agent."

5. If you choose a second person as an alternate, complete the next blank line with the second person's address and phone number. If you do not choose a second person as an alternate, leave this last line blank.

6. You must sign this form in front of a witness.

The witness cannot be related to you by blood, marriage or adoption, cannot be a beneficiary to your estate, and cannot be directly involved in your healthcare.

In Arizona, it is not necessary to have this form notarized, but there is a space for a notary. If you travel out of state with these documents, you may want to have your signature notarized.

7. Give a copy of this form to your Health Care (Medical) Power of Attorney, to your family and close friends, and to your doctor. Keep a copy to take to the hospital or clinic if you become ill and need treatment.



# HEALTH CARE DIRECTIVE (LIVING WILL)

I, \_\_\_\_\_ want everyone who cares for me to know what health care I want, when I cannot let others know what I want.

## SECTION 1:

I want my doctor to try treatments that may get me back to an acceptable quality of life. However, if my quality of life becomes unacceptable to me and my condition will not improve (is irreversible), I direct that all treatments that extend my life be withdrawn.

A quality of life that is unacceptable to me means (check all that apply):

- Unconscious (chronic coma or persistent vegetative state)
- Unable to communicate my needs
- Unable to recognize family or friends
- Total or near total dependence on others for care
- Other: \_\_\_\_\_

Check only one:

- Even if I have the quality of life described above, I still wish to be treated with food and water by tube or intravenously (IV).
- If I have the quality of life described above, I do NOT wish to be treated with food and water by tube or intravenously (IV).

## SECTION 2: (You may leave this section blank.)

Some people do not want certain treatments under any circumstance, even if they might recover.

Check the treatments below that you do not want under any circumstances:

- Cardiopulmonary Resuscitation (CPR)
- Ventilation (breathing machine)
- Feeding tube
- Dialysis
- Other: \_\_\_\_\_

## SECTION 3:

When I am near death, it is important to me that: \_\_\_\_\_  
\_\_\_\_\_  
\_\_\_\_\_

(Such as hospice care, place of death, funeral arrangements, cremation or burial preferences.)

## BE SURE TO SIGN PAGE TWO OF THIS FORM

- If you only want a Health Care (Medical) Power of Attorney, draw a large X through this page.
- Talk about this form with the person you have chosen to make decisions for you, your doctor(s), your family and friends. Give each of them a copy of this form.
- Take a copy of this with you whenever you go to the hospital or on a trip.
- You should review this form often.
- You can cancel or change this form at any time.

FOR MORE INFORMATION CONTACT HEALTH CARE DECISIONS, (602) 222-2229 OR [WWW.HCDECISIONS.ORG](http://WWW.HCDECISIONS.ORG)

**HEALTH CARE (MEDICAL) POWER OF ATTORNEY  
WITH MENTAL HEALTH AUTHORITY**

It is important to choose someone to make healthcare decisions for you when you cannot. **Tell the person (agent) you choose what you would want.** The person you choose has the right to make any decision to ensure that your wishes are honored. If you **DO NOT** choose someone to make decisions for you, write **NONE** in the line for the agent's name.

I, \_\_\_\_\_, as principal, designate  
\_\_\_\_\_ as my agent for all matters relating to my health (including mental health) and including, without limitation, full power to give or refuse consent to all medical, surgical, hospital and related health care. This power of attorney is effective on my inability to make or communicate health care decisions. All of my agent's actions under this power during any period when I am unable to make or communicate health care decisions or when there is uncertainty whether I am dead or alive have the same effect on my heirs, devisees and personal representatives as if I were alive, competent and acting for myself.

\_\_\_\_\_ By initialing here, I specifically consent to giving my agent the power to admit me to an inpatient or partial psychiatric hospitalization program if ordered by my physician.

\_\_\_\_\_ By initialing here, this Health Care Directive including Mental Health Care Power of Attorney may not be revoked if I am incapacitated.

Print agent ADDRESS and PHONE:

\_\_\_\_\_

If my agent is unwilling or unable to serve or continue to serve, I hereby appoint:

\_\_\_\_\_ as my agent.

Print alternate agent ADDRESS and PHONE:

\_\_\_\_\_

I intend for my agent to be treated as I would regarding the use and disclosure of my individually identifiable health information or other medical records. This release authority applies to any information governed by the Health Insurance Portability and Accountability Act of 1996 (aka HIPAA), 42 USC 1420D and 45 CFR 160-164.

**SIGN HERE for the Health Care (Medical) Power of Attorney and/or the Health Care Directive forms**

Please ask one person to witness your signature who is not related to you or financially connected to you or your estate.

Signature \_\_\_\_\_ Date \_\_\_\_\_

**The above named person is personally known to me, and I believe him/her to be of sound mind and to have completed this document voluntarily. I am at least 18 years old, not related to him/her by blood, marriage or adoption, and not an agent named in this document. I am not to my knowledge a beneficiary of his/her will or any codicil, and I have no claim against his/her estate. I am not directly involved in his/her health care.**

Witness \_\_\_\_\_ Date \_\_\_\_\_

This document may be notarized instead of witnessed.

On this \_\_\_\_\_ day of \_\_\_\_\_, in the year of \_\_\_\_\_, personally appeared before me the person signing, known by me to be the person who completed this document and acknowledged it as his/her free act and deed. IN WITNESS THEREOF, I have set my hand and affixed my official seal in the County of \_\_\_\_\_, State of \_\_\_\_\_, on the date written above.

Notary Public \_\_\_\_\_

**FOR MORE INFORMATION CONTACT HEALTH CARE DECISIONS, (602) 222-2229 OR WWW.HCDECISIONS.ORG**

**STATE OF ARIZONA**  
**LIVING WILL (End of Life Care)**  
Instructions and Form

**GENERAL INSTRUCTIONS:** Use this Living Will form to make decisions now about your medical care if you are ever in a terminal condition, a persistent vegetative state or an irreversible coma. You should talk to your doctor about what these terms mean. The Living Will states what choices you would have made for yourself if you were able to communicate. It is your written directions to your health care representative if you have one, your family, your physician, and any other person who might be in a position to make medical care decisions for you. Talk to your family members, friends, and others you trust about your choices. Also, it is a good idea to talk with professionals such as your doctor, clergy person and a lawyer before you complete and sign this Living Will.

If you decide this is the form you want to use, complete the form. **Do not sign the Living Will until** your witness or a Notary Public is present to watch you sign it. There are further instructions for you about signing on page 2.

**IMPORTANT: If you have a Living Will and a Durable Health Care Power of Attorney, you must attach the Living Will to the Durable Health Care Power of Attorney.**

**1. Information about me:** (I am called the "Principal")

My Name: \_\_\_\_\_ My Age: \_\_\_\_\_  
My Address: \_\_\_\_\_ My Date of Birth: \_\_\_\_\_  
My Telephone: \_\_\_\_\_

**2. My decisions about End of Life Care:**

**NOTE:** Here are some general statements about choices you have as to health care you want at the end of your life. They are listed in the order provided by Arizona law. You can initial any combination of paragraphs A, B, C, and D. **If you initial Paragraph E, do not initial any other paragraphs.** Read all of the statements carefully before initialing to indicate your choice. You can also write your own statement concerning life-sustaining treatments and other matters relating to your health care at Section 3 of this form.

- \_\_\_\_\_ **A. Comfort Care Only:** If I have a terminal condition I do not want my life to be prolonged, and I do not want life-sustaining treatment, beyond comfort care, that would serve only to artificially delay the moment of my death. (NOTE: "Comfort care" means treatment in an attempt to protect and enhance the quality of life without artificially prolonging life.)
- \_\_\_\_\_ **B. Specific Limitations on Medical Treatments I Want:** (NOTE: Initial or mark one or more choices, talk to your doctor about your choices.) If I have a terminal condition, or am in an irreversible coma or a persistent vegetative state that my doctors reasonably believe to be irreversible or incurable, I do want the medical treatment necessary to provide care that would keep me comfortable, but **I do not want the following:**
- \_\_\_\_\_ 1.) Cardiopulmonary resuscitation, for example, the use of drugs, electric shock, and artificial breathing.
- \_\_\_\_\_ 2.) Artificially administered food and fluids.
- \_\_\_\_\_ 3.) To be taken to a hospital if it is at all avoidable.
- \_\_\_\_\_ **C. Pregnancy:** Regardless of any other directions I have given in this Living Will, if I am known to be pregnant I do not want life-sustaining treatment withheld or withdrawn if it is possible that the embryo/fetus will develop to the point of live birth with the continued application of life-sustaining treatment.
- \_\_\_\_\_ **D. Treatment Until My Medical Condition is Reasonably Known:** Regardless of the directions I have made in this Living Will, I do want the use of all medical care necessary to treat my condition until my doctors reasonably conclude that my condition is terminal or is irreversible and incurable, or I am in a persistent vegetative state.
- \_\_\_\_\_ **E. Direction to Prolong My Life:** I want my life to be prolonged to the greatest extent possible.

**STATE OF ARIZONA  
LIVING WILL ("End of Life Care") (Cont'd)**

**3. Other Statements Or Wishes I Want Followed For End of Life Care:**

**NOTE:** You can attach additional provisions or limitations on medical care that have not been included in this Living Will form. Initial or put a check mark by box A or B below. Be sure to include the attachment if you check B.

- \_\_\_\_\_ **A.** I have not attached additional special provisions or limitations about End of Life Care I want.  
\_\_\_\_\_ **B.** I have attached additional special provisions or limitations about End of Life Care I want.

**SIGNATURE OR VERIFICATION**

**A.** I am signing this Living Will as follows:  
My Signature: \_\_\_\_\_ Date: \_\_\_\_\_

**B.** I am physically unable to sign this Living Will, so a witness is verifying my desires as follows:

**Witness Verification:** I believe that this Living Will accurately expresses the wishes communicated to me by the principal of this document. He/she intends to adopt this Living Will at this time. He/she is physically unable to sign or mark this document at this time. I verify that he/she directly indicated to me that the Living Will expresses his/her wishes and that he/she intends to adopt the Living Will at this time.

Witness Name (printed): \_\_\_\_\_  
Signature: \_\_\_\_\_ Date: \_\_\_\_\_

**SIGNATURE OF WITNESS OR NOTARY PUBLIC**

**NOTE:** At least one adult witness OR a Notary Public must witness you signing this document and then sign it. The witness or Notary Public CANNOT be anyone who is: (a) under the age of 18; (b) related to you by blood, adoption, or marriage; (c) entitled to any part of your estate; (d) appointed as your representative; or (e) involved in providing your health care at the time this document is signed.

**A. Witness:** I certify that I witnessed the signing of this document by the Principal. The person who signed this Living Will appeared to be of sound mind and under no pressure to make specific choices or sign the document. I understand the requirements of being a witness. I confirm the following:

- ◆ I am not currently designated to make medical decisions for this person.
- ◆ I am not directly involved in administering health care to this person.
- ◆ I am not entitled to any portion of this person's estate upon his or her death under a will or by operation of law.
- ◆ I am not related to this person by blood, marriage, or adoption.

Witness Name (printed): \_\_\_\_\_  
Signature: \_\_\_\_\_ Date: \_\_\_\_\_  
Address: \_\_\_\_\_

**B. Notary Public:** (NOTE: a Notary Public is only required if no witness signed above)

STATE OF ARIZONA ) ss  
COUNTY OF \_\_\_\_\_ )

The undersigned, being a Notary Public certified in Arizona, declares that the person making this Living Will has dated and signed or marked it in my presence, and appears to me to be of sound mind and free from duress. I further declare I am not related to the person signing above, by blood, marriage or adoption, or a person designated to make medical decisions on his/her behalf. I am not directly involved in providing health care to the person signing. I am not entitled to any part of his/her estate under a will now existing or by operation of law. In the event the person acknowledging this Living Will is physically unable to sign or mark this document, I verify that he/she directly indicated to me that the Living Will expresses his/her wishes and that he/she intends to adopt the Living Will at this time.

WITNESS MY HAND AND SEAL this \_\_\_\_\_ day of \_\_\_\_\_, 20\_\_\_\_.

Notary Public: \_\_\_\_\_ My commission expires: \_\_\_\_\_

**STATE OF ARIZONA**  
**LETTER TO MY REPRESENTATIVE(S)**  
**About Powers of Attorney Forms and Responsibilities**

**To My Representative:**

Name: \_\_\_\_\_  
Address: \_\_\_\_\_  
\_\_\_\_\_  
\_\_\_\_\_

**To My Alternate Representative:**

Name: \_\_\_\_\_  
Address: \_\_\_\_\_  
\_\_\_\_\_  
\_\_\_\_\_

**A. What I Ask You to Do For Me:** Arizona law allows me to make certain medical and financial decisions as to what I want in the future if I become unable or incapable of making certain decisions for myself. I have completed the following document(s), and I want you to be my representative or alternate representative for the following purposes. (Initial or check one or more of the following):

- \_\_\_\_\_ 1. Durable Health Care Power of Attorney  
\_\_\_\_\_ 2. Durable Mental Health Care Power of Attorney

**B. Why I Named an Alternate Representative:** I chose two representatives in case one of you is unable to act for me when the time arises. I ask that you accept my selection of you as my representative or alternate. If you do not return the Power of Attorney form(s) and this letter to me or inform me differently, I will assume that you have agreed to be my representative.

**C. Your Responsibilities as My Representative:** By selecting you, I am saying that I want you to make some very important decisions for me about my future health care needs if I become unable to make these decisions for myself. I might need you to carry out my medical choices as indicated in the enclosed Powers of Attorney, even if you do not agree with them. Please read the copies of the Powers of Attorney I am giving you. This is a very serious responsibility to accept. You will be my voice and will make medical decisions on my behalf. Other than what I have indicated in the Powers of Attorney as to my specific directions on certain issues, I am trusting your judgment to make decisions that you believe to be in my best interests. If at any time you do not feel that you can undertake this responsibility for any reason, please let me know. If you are unsure about any of my directions, please discuss them with me. If you are not willing to serve as my representative, please tell me so I can choose someone else to help me.

**As to Health Care:** You are not financially responsible for paying my health care costs merely by accepting this responsibility. Under Arizona law, you are not liable for complying with my decisions as stated in the Powers of Attorney or in making other health care decisions for me if you act in good faith.

**D. What Else You Should Do:** Please keep a copy of my Powers of Attorney and other documents in a safe place. Please read these documents carefully and discuss my choices with me at any time. I will give copies of my health care Powers of Attorney to my physician, and I will give copies of any or all of these Powers of Attorney to my family and any other representative I may choose. I authorize you to discuss with them the Powers of Attorney, including, as applicable, my medical situation, or any medical concerns about me. Please work with them and help them to act in accordance with my desires and in my best interests. I appreciate your support, and I thank you for your willingness to help me in this way.

Signature: \_\_\_\_\_ Date: \_\_\_\_\_

Printed Name: \_\_\_\_\_

**STATE OF ARIZONA  
DURABLE HEALTH CARE POWER OF ATTORNEY  
Instructions and Form**

**GENERAL INSTRUCTIONS:** Use this Durable Health Care Power of Attorney form if you want to select a person to make future health care decisions for you so that if you become too ill or cannot make those decisions for yourself the person you choose and trust can make medical decisions for you. Talk to your family, friends, and others you trust about your choices. Also, it is a good idea to talk with professionals such as your doctor, clergyperson and a lawyer before you sign this form.

Be sure you understand the importance of this document. If you decide this is the form you want to use, complete the form. **Do not sign this form until** your witness or a Notary Public is present to witness the signing. There are further instructions for you about signing this form on page three.

**1. Information about me:** (I am called the "Principal")

My Name: \_\_\_\_\_ My Age: \_\_\_\_\_  
My Address: \_\_\_\_\_ My Date of Birth: \_\_\_\_\_  
\_\_\_\_\_ My Telephone: \_\_\_\_\_

**2. Selection of my health care representative and alternate:** (Also called an "agent" or "surrogate")

I choose the following person to act as my representative to make health care decisions for me:

Name: \_\_\_\_\_ Home Telephone: \_\_\_\_\_  
Street Address: \_\_\_\_\_ Work Telephone: \_\_\_\_\_  
City, State, Zip: \_\_\_\_\_ Cell Telephone: \_\_\_\_\_

I choose the following person to act as an alternate representative to make health care decisions for me if my first representative is unavailable, unwilling, or unable to make decisions for me:

Name: \_\_\_\_\_ Home Telephone: \_\_\_\_\_  
Street Address: \_\_\_\_\_ Work Telephone: \_\_\_\_\_  
City, State, Zip: \_\_\_\_\_ Cell Telephone: \_\_\_\_\_

**3. What I AUTHORIZE if I am unable to make medical care decisions for myself:**

I authorize my health care representative to make health care decisions for me when I cannot make or communicate my own health care decisions due to mental or physical illness, injury, disability, or incapacity. I want my representative to make all such decisions for me except those decisions that I have expressly stated in Part 4 below that I do not authorize him/her to make. If I am able to communicate in any manner, my representative should discuss my health care options with me. My representative should explain to me any choices he or she made if I am able to understand. This appointment is effective unless and until it is revoked by me or by an order of a court.

The types of health care decisions I authorize to be made on my behalf include but are not limited to the following:

- To consent or to refuse medical care, including diagnostic, surgical, or therapeutic procedures;
- To authorize the physicians, nurses, therapists, and other health care providers of his/her choice to provide care for me, and to obligate my resources or my estate to pay reasonable compensation for these services;
- To approve or deny my admittance to health care institutions, nursing homes, assisted living facilities, or other facilities or programs. By signing this form I understand that I allow my representative to make decisions about my mental health care except that generally speaking he or she cannot have me admitted to a structured treatment setting with 24-hour-a-day supervision and an intensive treatment program – called a "level one" behavioral health facility – using just this form;

## DURABLE HEALTH CARE POWER OF ATTORNEY (Cont'd)

- To have access to and control over my medical records and to have the authority to discuss those records with health care providers.

### 4. DECISIONS I EXPRESSLY DO NOT AUTHORIZE my Representative to make for me:

I do not want my representative to make the following health care decisions for me (describe or write in "not applicable"):

---

---

---

---

---

### 5. My specific desires about autopsy:

NOTE: Under Arizona law, an autopsy is not required unless the county medical examiner, the county attorney, or a superior court judge orders it to be performed. See the General Information document for more information about this topic. Initial or put a check mark by one of the following choices.

- Upon my death I DO NOT consent to (want) an autopsy.  
 Upon my death I DO consent to (want) an autopsy.  
 My representative may give or refuse consent for an autopsy.

### 6. My specific desires about organ donation: ("anatomical gift")

NOTE: Under Arizona law, you may donate all or part of your body. If you do not make a choice, your representative or family can make the decision when you die. You may indicate which organs or tissues you want to donate and where you want them donated. Initial or put a check mark by A or B below. If you select B, continue with your choices.

- A. I DO NOT WANT** to make an organ or tissue donation, and I do not want this donation authorized on my behalf by my representative or my family.  
 **B. I DO WANT** to make an organ or tissue donation when I die. Here are my directions:

#### 1. What organs/tissues I choose to donate: (Select a or b below)

- a.** Any needed parts or organs.  
 **b.** These parts or organs:  
1.) \_\_\_\_\_  
2.) \_\_\_\_\_  
3.) \_\_\_\_\_

#### 2. What purposes I donate organs/tissues for: (Select a, b, or c below)

- a.** Any legally authorized purpose (transplantation, therapy, medical and dental evaluation and research, and/or advancement of medical and dental science).  
 **b.** Transplant or therapeutic purposes only.  
 **c.** Other: \_\_\_\_\_

#### 3. What organization or person I want my parts or organs to go to:

- a.** I have already signed a written agreement or donor card regarding organ and tissue donation with the following individual or institution: (Name) \_\_\_\_\_  
 **b.** I would like my tissues or organs to go to the following individual or institution: (Name) \_\_\_\_\_  
 **c.** I authorize my representative to make this decision.

**DURABLE HEALTH CARE POWER OF ATTORNEY (Cont'd)**

**7. Funeral and Burial Disposition: (Optional)**

My agent has authority to carry out all matters relating to my funeral and burial disposition wishes in accordance with this power of attorney, which is effective upon my death. My wishes are reflected below:

**Initial or put a check mark by those choices you wish to select.**

- Upon my death, I direct my body to be buried. (As opposed to cremated)
- Upon my death, I direct my body to be buried in \_\_\_\_\_ . (Optional directive)
- Upon my death, I direct my body to be cremated.
- Upon my death, I direct my body to be cremated with my ashes to be \_\_\_\_\_ . (Optional directive)
- My agent will make all funeral and burial disposition decisions. (Optional directive)

**8. About a Living Will:**

NOTE: If you have a Living Will and a Durable Health Care Power of Attorney, **you must attach** the Living Will to this form. A Living Will form is available on the Attorney General (AG) web site. Initial or put a check mark by box A or B.

- A.** I have SIGNED AND ATTACHED a completed Living Will in addition to this Durable Health Care Power of Attorney to state decisions I have made about end of life health care if I am unable to communicate or make my own decisions at that time.
- B.** I have NOT SIGNED a Living Will.

**9. About a Prehospital Medical Care Directive or Do Not Resuscitate Directive:**

NOTE: A form for the Prehospital Medical Care Directive or Do Not Resuscitate Directive is available on the AG Web site. Initial or put a check mark by box A or B.

- A.** I and my doctor or health care provider HAVE SIGNED a Prehospital Medical Care Directive or Do Not Resuscitate Directive on paper with ORANGE background in the event that 911 or Emergency Medical Technicians or hospital emergency personnel are called and my heart or breathing has stopped.
- B.** I have NOT SIGNED a Prehospital Medical Care Directive or Do Not Resuscitate Directive.

**HIPPA WAIVER OF CONFIDENTIALITY FOR MY AGENT/REPRESENTATIVE**

**(Initial)** I intend for my agent to be treated as I would be with respect to my rights regarding the use and disclosure of my individually identifiable health information or other medical records. This release authority applies to any information governed by the Health Insurance Portability and Accountability Act of 1996 (aka HIPAA), 42 USC 1320d and 45 CFR 160-164.

**SIGNATURE OR VERIFICATION**

**A.** I am signing this Durable Health Care Power of Attorney as follows:

My Signature: \_\_\_\_\_ Date: \_\_\_\_\_

**B.** I am physically unable to sign this document, so a witness is verifying my desires as follows:

**Witness Verification:** I believe that this Durable Health Care Power of Attorney accurately expresses the wishes communicated to me by the principal of this document. He/she intends to adopt this Durable Health Care Power of Attorney at this time. He/she is physically unable to sign or mark this document at this time, and I verify that he/she directly indicated to me that the Durable Health Care Power of Attorney expresses his/her wishes and that he/she intends to adopt the Durable Health Care Power of Attorney at this time.



**DURABLE HEALTH CARE POWER OF ATTORNEY (Cont'd)**

Witness Name (printed): \_\_\_\_\_  
Signature: \_\_\_\_\_ Date: \_\_\_\_\_

**SIGNATURE OF WITNESS OR NOTARY PUBLIC:**

NOTE: At least one adult witness OR a Notary Public must witness the signing of this document and then sign it. The witness or Notary Public CANNOT be anyone who is: (a) under the age of 18; (b) related to you by blood, adoption, or marriage; (c) entitled to any part of your estate; (d) appointed as your representative; or (e) involved in providing your health care at the time this form is signed.

**A. Witness:** I certify that I witnessed the signing of this document by the Principal. The person who signed this Durable Health Care Power of Attorney appeared to be of sound mind and under no pressure to make specific choices or sign the document. I understand the requirements of being a witness and I confirm the following:

- I am not currently designated to make medical decisions for this person.
- I am not directly involved in administering health care to this person.
- I am not entitled to any portion of this person's estate upon his or her death under a will or by operation of law.
- I am not related to this person by blood, marriage or adoption.

Witness Name (printed): \_\_\_\_\_  
Signature: \_\_\_\_\_ Date: \_\_\_\_\_  
Address: \_\_\_\_\_

**Notary Public** (NOTE: If a witness signs your form, you DO NOT need a notary to sign):

STATE OF ARIZONA ) ss  
COUNTY OF \_\_\_\_\_)

The undersigned, being a Notary Public certified in Arizona, declares that the person making this Durable Health Care Power of Attorney has dated and signed or marked it in my presence and appears to me to be of sound mind and free from duress. I further declare I am not related to the person signing above by blood, marriage or adoption, or a person designated to make medical decisions on his/her behalf. I am not directly involved in providing health care to the person signing. I am not entitled to any part of his/her estate under a will now existing or by operation of law. In the event the person acknowledging this Durable Health Care Power of Attorney is physically unable to sign or mark this document, I verify that he/she directly indicated to me that this Durable Health Care Power of Attorney expresses his/her wishes and that he/she intends to adopt the Durable Health Care Power of Attorney at this time.

WITNESS MY HAND AND SEAL this \_\_\_ day of \_\_\_\_\_, 20\_\_.  
Notary Public \_\_\_\_\_ My Commission Expires: \_\_\_\_\_

**OPTIONAL:  
STATEMENT THAT YOU HAVE DISCUSSED  
YOUR HEALTH CARE CHOICES FOR THE FUTURE  
WITH YOUR PHYSICIAN**

NOTE: Before deciding what health care you want for yourself, you may wish to ask your physician questions regarding treatment alternatives. This statement from your physician is not required by Arizona law. If you do speak with your physician, it is a good idea to have him or her complete this section. Ask your doctor to keep a copy of this form with your medical records.

**DURABLE HEALTH CARE POWER OF ATTORNEY (Last Page)**

On this date I reviewed this document with the Principal and discussed any questions regarding the probable medical consequences of the treatment choices provided above. I agree to comply with the provisions of this directive, and I will comply with the health care decisions made by the representative unless a decision violates my conscience. In such case I will promptly disclose my unwillingness to comply and will transfer or try to transfer patient care to another provider who is willing to act in accordance with the representative's direction.

Doctor Name (printed): \_\_\_\_\_  
Signature: \_\_\_\_\_ Date: \_\_\_\_\_  
Address: \_\_\_\_\_

**STATE OF ARIZONA  
DURABLE MENTAL HEALTH CARE POWER OF ATTORNEY  
Instructions and Form**

**GENERAL INSTRUCTIONS:** Use this Durable Mental Health Care Power of Attorney form if you want to appoint a person to make future mental health care decisions for you if you become incapable of making those decisions for yourself. The decision about whether you are incapable can only be made by an Arizona licensed psychiatrist or psychologist who will evaluate whether you can give informed consent. Be sure you understand the importance of this document. Talk to your family members, friends, and others you trust about your choices. Also, it is a good idea to talk with professionals such as your doctor, clergyperson, and a lawyer before you sign this form.

If you decide this is the form you want to use, complete the form. **Do not sign this form until** your witness or a Notary Public is present to witness the signing. There are more instructions about signing this form on page 3.

**1. Information about me:** (I am called the "Principal")

My Name: \_\_\_\_\_ My Age: \_\_\_\_\_  
My Address: \_\_\_\_\_ My Date of Birth: \_\_\_\_\_  
\_\_\_\_\_ My Telephone: \_\_\_\_\_

**2. Selection of my health care representative and alternate:** (Also called an "agent" or "surrogate")

I choose the following person to act as my representative to make mental health care decisions for me:

Name: \_\_\_\_\_ Home Telephone: \_\_\_\_\_  
Street Address: \_\_\_\_\_ Work Telephone: \_\_\_\_\_  
City, State, Zip: \_\_\_\_\_ Cell Telephone: \_\_\_\_\_

I choose the following person to act as an alternate representative to make mental health care decisions for me if my first representative is unavailable, unwilling, or unable to make decisions for me:

Name: \_\_\_\_\_ Home Telephone: \_\_\_\_\_  
Street Address: \_\_\_\_\_ Work Telephone: \_\_\_\_\_  
City, State, Zip: \_\_\_\_\_ Cell Telephone: \_\_\_\_\_

**3. Mental health treatments that I AUTHORIZE if I am unable to make decisions for myself:**

Here are the mental health treatments I authorize my mental health care representative to make on my behalf if I become incapable of making my own mental health care decisions due to mental or physical illness, injury, disability, or incapacity. If my wishes are not clear from this Durable Mental Health Care Power of Attorney or are not otherwise known to my representative, my representative will, in good faith, act in accordance with my best interests. This appointment is effective unless and until it is revoked by me or by an order of a court. My representative is authorized to do the following **which I have initialed or marked:**

- \_\_\_\_\_ **A. About my records:** To receive information regarding mental health treatment that is proposed for me and to receive, review, and consent to disclosure of any of my medical records related to that treatment.
- \_\_\_\_\_ **B. About medications:** To consent to the administration of any medications recommended by my treating physician.
- \_\_\_\_\_ **C. About a structured treatment setting:** To admit me to a structured treatment setting with 24-hour-a-day supervision and an intensive treatment program licensed by the Department of Health Services, which is called a "level one" behavioral health facility.
- \_\_\_\_\_ **D. Other:** \_\_\_\_\_  
\_\_\_\_\_  
\_\_\_\_\_

**DURABLE MENTAL HEALTH CARE POWER OF ATTORNEY (Cont'd)**

**4. Durable Mental health treatments that I expressly DO NOT AUTHORIZE if I am unable to make decisions for myself:** (Explain or write in "None")

---

---

---

**5. Revocability of this Durable Mental Health Care Power of Attorney:** This Durable Mental Health Care Power of Attorney is made under Arizona law and continues in effect for all who rely upon it except those who have received oral or written notice of its revocation. Further, I want to be able to revoke this Durable Mental Health Care Power of Attorney as follows: (Initial or mark A or B.)

- \_\_\_\_\_ **A.** This Durable Mental Health Care Power of Attorney is IRREVOCABLE if I am unable to give informed consent to mental health treatment.
- \_\_\_\_\_ **B.** This Durable Mental Health Care Power of Attorney is REVOCABLE at all times if I do any of the following:
- 1.) Make a written revocation of the Durable Mental Health Care Power of Attorney or a written statement to disqualify my representative or agent.
  - 2.) Orally notify my representative or agent or a mental health care provider that I am revoking.
  - 3.) Make a new Durable Mental Health Care Power of Attorney.
  - 4.) Any other act that demonstrates my specific intent to revoke a Durable Mental Health Care Power of Attorney or to disqualify my agent.

**6. Additional information** about my mental health care treatment needs (consider including mental or physical health history, dietary requirements, religious concerns, people to notify and any other matters that you feel are important):

---

---

---

**HIPPA WAIVER OF CONFIDENTIALITY FOR MY AGENT/REPRESENTATIVE**

\_\_\_\_\_ **(Initial)** I intend for my agent to be treated as I would be with respect to my rights regarding the use and disclosure of my individually identifiable health information or other medical records. This release authority applies to any information governed by the Health Insurance Portability and Accountability Act of 1996 (aka HIPAA), 42 USC 1320d and 45 CFR 160-164.

**SIGNATURE OR VERIFICATION**

**A. I am signing this Durable Mental Health Care Power of Attorney as follows:**

My Signature: \_\_\_\_\_ Date: \_\_\_\_\_

**B. I am physically unable to sign this document, so a witness is verifying my desires as follows:**

**Witness Verification:** I believe that this Durable Mental Health Care Power of Attorney accurately expresses the wishes communicated to me by the Principal of this document. He/she intends to adopt this Durable Mental Health Care Power of Attorney at this time. He/she is physically unable to sign or mark this document at this time. I verify that he/she directly indicated to me that the Durable Mental Health Care Power of Attorney expresses his/her wishes and that he/she intends to adopt the Durable Mental Health Care Power of Attorney at this time.

Witness Name (printed): \_\_\_\_\_

Signature: \_\_\_\_\_ Date: \_\_\_\_\_

**DURABLE MENTAL HEALTH CARE POWER OF ATTORNEY (Last Page)**

**SIGNATURE OF WITNESS OR NOTARY PUBLIC**

**NOTE:** At least one adult witness OR a Notary Public must witness the signing of this document and then sign it. The witness or Notary Public CANNOT be anyone who is: (a) under the age of 18; (b) related to you by blood, adoption, or marriage; (c) entitled to any part of your estate; (d) appointed as your representative; or (e) involved in providing your health care at the time this document is signed.

**A. Witness:** I affirm that I personally know the person signing this Durable Mental Health Care Power of Attorney and that I witnessed the person sign or acknowledge the person's signature on this document in my presence. I further affirm that he/she appears to be of sound mind and not under duress, fraud, or undue influence. He/she is not related to me by blood, marriage, or adoption and is not a person for whom I directly provide care in a professional capacity. I have not been appointed as the representative to make medical decisions on his/her behalf.

Witness Name (printed): \_\_\_\_\_  
Signature: \_\_\_\_\_ Date and time: \_\_\_\_\_  
Address: \_\_\_\_\_

**B. Notary Public:** (NOTE: If a witness signs your form, you DO NOT need a notary to sign)

STATE OF ARIZONA ) ss  
COUNTY OF \_\_\_\_\_ )

The undersigned, being a Notary Public certified in Arizona, declares that the person making this Durable Mental Health Care Power of Attorney has dated and signed or marked it in my presence and appears to me to be of sound mind and free from duress. I further declare I am not related to the person signing above, by blood, marriage or adoption, or a person designated to make medical decisions on his/her behalf. I am not directly involved in providing care as a professional to the person signing. I am not entitled to any part of his/her estate under a will now existing or by operation of law. In the event the person acknowledging this Durable Mental Health Care Power of Attorney is physically unable to sign or mark this document, I verify that he/she directly indicated to me that the Durable Mental Health Care Power of Attorney expresses his/her wishes and that he/she intends to adopt the Durable Mental Health Care Power of Attorney at this time.

WITNESS MY HAND AND SEAL this \_\_\_\_ day of \_\_\_\_\_, 20\_\_.  
Notary Public: \_\_\_\_\_ My commission expires: \_\_\_\_\_

**OPTIONAL:  
REPRESENTATIVE'S ACCEPTANCE OF APPOINTMENT**

I accept this appointment and agree to serve as agent to make mental health treatment decisions for the Principal. I understand that I must act consistently with the wishes of the person I represent as expressed in this Durable Mental Health Care Power of Attorney or, if not expressed, as otherwise known by me. If I do not know the Principal's wishes, I have a duty to act in what I, in good faith, believe to be that person's best interests. I understand that this document gives me the authority to make decisions about mental health treatment only while that person has been determined to be incapacitated which means under Arizona law that a licensed psychiatrist or psychologist has the opinion that the Principal is unable to give informed consent.

Representative Name (printed): \_\_\_\_\_  
Signature: \_\_\_\_\_ Date: \_\_\_\_\_



## LAST WILL AND TESTAMENT FOR HUMAN REMAINS AND AUTHORIZATION OF ANATOMICAL DONATION

7895 East Acoma Drive, Suite 110  
Scottsdale, AZ 85260-6916

- 1) I, «FNAME» «MNAME» «LNAME», now residing at «ADDR1», «CITY», «STATE» «ZIP», being of sound mind and memory, and over the age of majority, declare this to be my Last Will and Testament regarding my human remains, which declaration may only be revoked by a subsequent testamentary document making specific reference by document and date revoking this declaration. It is my wish that upon my legal death my human remains be preserved by the cryogenic treatment known as cryopreservation.
  
- 2) For this purpose, and in accordance with the laws governing anatomical donations, I hereby:
  - a) donate my human remains to the Alcor Life Extension Foundation, Inc. ("Alcor"), a California non-profit corporation, registered with the Internal Revenue Service as a tax-exempt scientific and educational organization, having its principal office and place of business at 7895 E. Acoma Dr., #110, Scottsdale, AZ 85260-6916, such donation to take place immediately after my legal death, and
  
  - b) direct that upon my legal death my human remains be delivered to Alcor or to its agents or representatives, at such place as they may direct.
  
- 3) I further direct that, when and where possible, such delivery shall take place immediately after my legal death, without embalming or autopsy.
  
- 4) I further declare that I have not received any remuneration whatsoever in connection with this donation of my human remains, and that I have made this donation for the purpose of furthering cryobiological and cryonic research.
  
- 5) I understand and intend that this Anatomical Donation gives Alcor full and complete custody and control of my human remains.

6) I further intend and direct that such custody and control give Alcor status of "next-of-kin" regarding my human remains, so that Alcor shall have the authority to accomplish any necessary actions in connection with this anatomical donation. As part of granting this status, I specifically authorize Alcor to:

a) direct cremation or other disposition of any non-cryopreserved portion of my human remains.

b) request and receive copies of any and all medical or psychiatric records regarding treatment I may have received at any time during my life.

7) I understand that cryopreservation of my human remains constitutes a research project, and that cryopreservation is not consistent with contemporary medical or mortuary practice. As stated in the other forms I have signed for Alcor, I understand that there are no guarantees or any known probability that the procedure of cryopreservation will be successful.

8) If a legal challenge is raised to this Authorization of Anatomical Donation, I authorize Alcor to take custody of, and have full and complete control over, my human remains by whatever legal means may be available for the purpose of placing them into cryopreservation. If a legal challenge to this procedure is raised by any institution, individual(s), or government agency, I authorize Alcor to use monies from my Cryopreservation Fund to pay for the legal expenses involved in defending its authority and ability to place my human remains into cryopreservation.

9) In witness thereof, I hereby sign, publish, and declare this to be my Last Will and Testament regarding my human remains unless revoked as specifically provided within this agreement, and this document is signed in conjunction with the **Cryopreservation Agreement** and the **Consent for Cryopreservation**, all three of which together constitute my last wish and instruction concerning the disposition of my human remains following my legal death.

\_\_\_\_\_  
Signature of Donor

\_\_\_\_\_\ \ \_\_\_\_\_\ \ 20\_\_\_\_\_  
Month    Day            Year

\_\_\_\_\_(a.m./p.m.)  
Time

**WITNESSES' SIGNATURES**

***[Two (2) witnesses are required to sign in the presence of each other, the Donor, and a Notary Public. At the time of signing, witnesses must not be relatives of the Donor, health care providers of any kind, or officers, directors, or agents of Alcor. The witnessing Notary Public must then notarize this document on the final page. COMPLETION OF NOTARY FORM IS OPTIONAL IN THE STATE OF CALIFORNIA.]***

We, the undersigned witnesses, sign our names to this instrument, being first duly sworn, and do hereby declare to the undersigned authority that the Donor signs and executes this instrument as his/her Last Will and Testament regarding his/her human remains, and that the Donor signed this document willingly, and that each of us, in the presence and hearing of the Donor hereby signs this Will as Witness to the Donor signing, and that to the best of our knowledge, the Donor is over the age of majority, of sound mind and memory, and under no constraint or undue influence. We further affirm that we are not relatives of the Donor, health care providers of any kind, or officers, directors, or agents of Alcor.

WITNESSED ON (MM\DD\YY) \_\_\_\_\_ \ \_\_\_\_\_ \ 20\_\_\_\_ TIME \_\_\_\_\_(a.m.\p.m.)

1. Signature \_\_\_\_\_

Printed \_\_\_\_\_

Social Security # (optional) \_\_\_\_\_

Address \_\_\_\_\_

City, State, Zip \_\_\_\_\_

2. Signature \_\_\_\_\_

Printed \_\_\_\_\_

Social Security # (optional) \_\_\_\_\_

Address \_\_\_\_\_

City, State, Zip \_\_\_\_\_



**PLEASE READ ALL INSTRUCTIONS PRIOR TO COMPLETION.**

- 1. All blanks must be correctly completed by a notary public and notarial seal provided before this document can be approved.**
- 2. The notary cannot be a witness.**
- 3. Notarization is optional in the state of California.**

STATE OF \_\_\_\_\_ )  
 ) ss  
County of \_\_\_\_\_ )

My commission expires:

\_\_\_\_\_

SUBSCRIBED, SWORN TO and ACKNOWLEDGED before me by \_\_\_\_\_,  
MEMBER NAME

the Donor/Testator, and subscribed and sworn to before me by \_\_\_\_\_ and  
WITNESS NAME

\_\_\_\_\_, the witnesses, on (MM\DD\YY) \_\_\_\_ \ \_\_\_\_ \ 20\_\_\_\_.  
WITNESS NAME

\_\_\_\_\_  
PRINTED NAME OF NOTARY PUBLIC

\_\_\_\_\_  
SIGNATURE OF NOTARY PUBLIC

\_\_\_\_\_  
SEAL HERE

## **5: Autopsy**

### **Terminology**

An autopsy is a surgical procedure performed after legal death in an effort to determine how death occurred. Historically in the United States this procedure was performed by a coroner, who was either an elected or an appointed official employed by the county or city in which death occurred. A coroner was not required have to have any formal medical training, and in rural areas of the country the role may still be filled on that basis.

In many parts of the country the position of coroner has been superceded by that of a medical examiner, who is usually appointed to the job and is usually a physician, ideally specializing in pathology or forensic medicine.

For convenience, in this section we will use the term “medical examiner” throughout, on the understanding that our statements apply equally to a coroner.

### **Autopsy Fundamentals**

To determine or confirm the cause of death, usually an autopsy entails removing and dissecting of the brain, which is then wrapped and placed in the abdominal cavity.

The procedure is catastrophic for anyone who wishes to be cryopreserved with minimal injury. The patient may be stored for more than one day (in some cases, for more than a week) while waiting for an autopsy to be performed. Storage is often around 5 degrees Celsius, but in rare instances freezing may be allowed to occur.

Typically the local medical examiner performs or supervises the autopsy after it has been requested by a physician. The cryonics organization usually is not allowed access to the patient until the autopsy has been completed.

## **Natural and Unnatural Death**

Generally an autopsy is most likely in a case of unnatural death, and least likely in a case of natural death. It is important to understand the distinction between these terms.

*Natural death* is often caused by a known illness or by a chain of medical consequences stemming from a known illness. While state laws vary, natural death may be assumed if:

- A patient dies more than 24 hours after admission to a hospital, or under supervision of hospice staff, OR
- A patient dies of a condition which has been diagnosed or treated by a physician within the past 30 days.

*Unnatural death* is a catch-all definition which applies where accidents, foul play, suicide, drug overdoses, or unknown diseases have occurred. If a person dies alone and is discovered subsequently, the death may be considered unnatural. While the definition will vary depending on state law, the following list of causes is typical:

- Criminal violence.
- Accident.
- Suicide.
- Suddenly, when in apparent good health.
- Unattended by a practicing physician or other recognized practitioner.
- In any prison or penal institution.
- In police custody.

- In any suspicious or unusual circumstance.
- By criminal abortion.
- By poison.
- By a disease constituting a threat to public health.
- By disease, injury or toxic agent resulting from employment.
- When a dead body is brought into the State without proper medical certification.
- When a body is going to be cremated, dissected, or buried at sea, the inability to exhume the body for subsequent examination may provide some additional incentive to perform an autopsy.

## **How an Autopsy Occurs**

A *forensic autopsy* is performed if there is any possibility of criminal investigation arising from suspicion of foul play, or civil suits relating to negligence, or other legal issues such as an insurance company seeking to withhold death benefit in a case of suicide. A forensic autopsy may also be justified on grounds of protecting the public from risk if death may have occurred as a result of an unknown pathogen.

A *clinical autopsy* usually has no legal basis and may simply provide useful information for any organization which has had custody of the patient. Thus, a hospital may seek to obtain data of medical interest, such as the effects of prior treatment or the accuracy of a diagnosis. Clinical autopsy is also used in the education of medical students.

A cryonics organizations may have a good chance of averting a clinical autopsy if it receives timely notification that the patient has died. A hospital representative may try to create the impression that an autopsy is customary, but if the medical examiner is not involved, the cryonics organization can argue strenuously against it (or can encourage next of kin to do so) with some confidence of success.

The situation is much more difficult in cases of unnatural death such as those itemized above. An attending physician may insist on notifying the medical examiner, and if the cryonics organization attempts to prevent this too strenuously, it risks being accused of obstruction of justice.

Because unnatural death often occurs suddenly and unexpectedly, the cryonics organization may not discover that it has happened until after the medical examiner has been informed. At this point the organization usually has only two options available:

1. Contact the medical examiner to dispute the need for an autopsy, and show readiness to seek an injunction against it if necessary.
2. If Option 1 is unsuccessful, request a minimally invasive procedure that will be performed as quickly as possible.

Switching from Option 1 to Option 2 may be difficult, as the first option tends to entail a confrontational position, while the second option entails a request for cooperation. However, requests for expedited autopsy have sometimes been successful. One of the authors (Platt) participated in a case where the waiting time was reduced from three days to one day, and dissection was relatively minor. The brain was still removed from the skull, however, making cryoprotective perfusion impossible. Under these circumstances, we can only speculate whether a one-day waiting period was significantly less damaging than a three-day waiting period.

Note that a mortician or funeral director may not have to be involved in an autopsy case, if cryonics personnel are able to complete all the necessary paperwork and arrange for shipment of the patient via a cooperating airline. While a mortuary is often used as a location in which to perform cryoprotective perfusion, this is impossible after a patient has gone through two or more days of ischemia and has then undergone some dissection.

## **How Likely is an Autopsy?**

In 2009 the National Center for Health Statistics published the ten leading causes of death in the United States:

1. Heart disease
2. Cancer
3. Chronic lower respiratory diseases
4. Stroke (cerebrovascular diseases)
5. Accidents (unintentional injuries)
6. Alzheimer's disease
7. Diabetes
8. Influenza and Pneumonia
9. Nephritis, nephrotic syndrome, and nephrosis
10. Intentional self-harm (suicide)

On the positive side, only causes 5 and 10 will typically result in an autopsy, and if the cause of accidental death is obvious (such as falling off a step ladder) a medical examiner may feel that an autopsy is unnecessary.

On the negative side, an event such as cardiac arrest or stroke can lead to an autopsy if death occurs while the person is alone, and there is no recent medical history. For a discussion of ways in which a cryonicist can try to avoid a situation where autopsy is likely, see "How Not To Die Like That: Reducing Your Risk of Autopsy" by Mike Darwin and Steve Harris in *Cryonics* magazine, October, 1987, Volume 8 (10 & 12).

## **Pre-Emptying an Autopsy**

The risk of an autopsy may be reduced preemptively by cryonicists while they are still alive. They may contact their local medical examiner and seek a meeting in which they can explain the rationale for cryonics and the reasons why an autopsy is extremely undesirable. The medical examiner may have some professional interest in learning about cryopreservation procedures, and in an ideal situation might become an ally rather than an adversary.

Unfortunately, experience has shown that this scenario is vanishingly unlikely, as few cryonicists have tried to pursue the strategy. Moreover, the medical examiner whom a cryonicist meets this year may be replaced by a different individual next year.

As a fallback strategy, cryonics organizations have encouraged their members to carry a wallet card expressing a strong objection to autopsy. The web sites of Alcor and the Cryonics Institute link to the relevant forms that their members can execute. The Venturist cryonics advocacy organization offers a card for their members stating a religious objection. An example is shown in Figure 5-1.

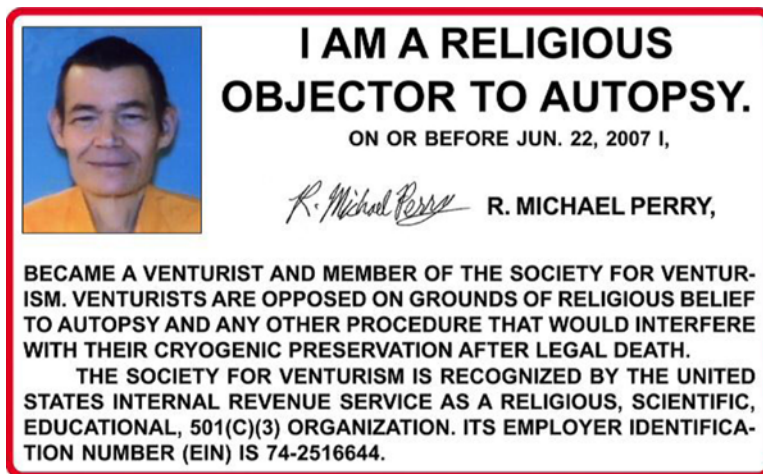

Figure 5-1. A wallet card for members of the Venturist society, objecting to autopsy.

The term “religious objection” may seem inappropriate to cryopreservation procedures, but is used because a medical examiner will be familiar with it. Many religious groups are strongly opposed to the mutilation of dead bodies. They may also believe that the body must be retained and buried as close to the location of death as possible, or that the body needs to remain intact for a successful passage to the afterlife, or that the body must be buried as quickly as possible after death has occurred. Orthodox Jews, certain schools within Islam, and Native Americans have a strong tradition of objecting to autopsy.

Seven states (California, Louisiana, Maryland, New Jersey, New York, Ohio, and Rhode Island) have passed laws that recognize the importance of these religious beliefs. The California statute is particularly strong, stating that if a coroner has received a certificate executed by a patient “stating the procedure [of autopsy] would be contrary to his or her religious belief, the coroner shall not perform that procedure on the body of the decedent.” Some states also respect the patient’s wishes even if they have only been expressed verbally.

Unfortunately these laws allow a major loophole. If the local medical examiner suspects that a criminal act may have occurred, or that the patient may have died from a disease that could endanger the community, he has the right to authorize a forensic autopsy regardless of the wishes of the patient, the cryonics organization, relatives, and almost anyone else, with the exception of a judge. Theoretically a cryonics organization may go to court to seek an injunction preventing a forensic autopsy, and in one instance was successful (during the case of Alcor member Dora Kent). Such cases are extremely rare.

If an autopsy cannot be prevented, representatives of the cryonics organization must do their best to appear cooperative in the hope of minimizing the damage. The procedure may seem intolerably destructive, but if the cryonics organization has decided to cooperate, team members should refrain from expressing their personal feelings about it.

A religious representative may attend an autopsy to ensure that it conforms as closely as possible to the guidelines of a specific belief. Similarly, a cryonics organization may ask to send a representative or a family member with good knowledge about cryonics, to observe that the autopsy does not do unnecessary harm to the brain and the patient is kept cold. To our knowledge such a request has not been made yet in cryonics but it might be possible, especially if the member has made a religious objection to autopsy or a relative is involved.

## **The Ultrastructural Case Against Autopsy**

Cryonics advocates claim that people who are routinely designated as “corpses” may still retain the neuroanatomical basis of identity that makes



them who they are. Against the folk wisdom that a person's brain "dies" after five minutes after circulatory arrest, they point out that the challenge of resuscitating the person does not so much involve the instant decomposition of the brain but complex biochemical pathways that induce (delayed) apoptosis and prevent full cognitive recovery. Scientific studies that look at the ultrastructure of the brain after (permanent) ischemia support this outlook. In fact, even after a prolonged period of warm ischemia the damage does not seem sufficient to substantially damage brain structure to a degree that the original structure cannot be inferred.

In 2009 the Alcor Life Extension Foundation launched a research project to model ultrastructural alterations after various periods of warm ischemia (normothermia). As can be seen in the electron micrograph in Figure 5-2, even at 21 hours of warm ischemia well defined organelles and lipids (myelin) can still be observed in the image.

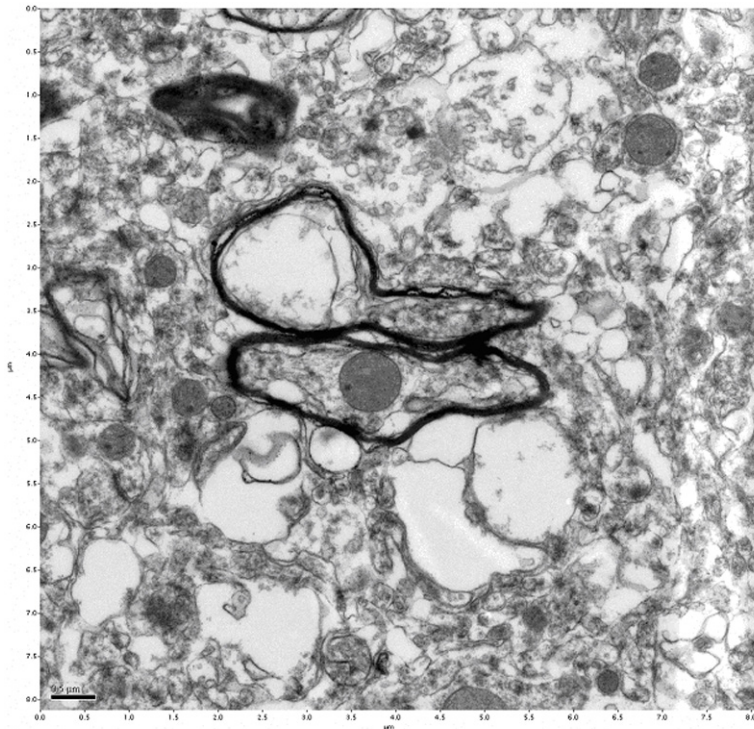

*Figure 5-2. Electron micrograph of an animal brain after 21 hours of warm ischemia.*

A potential rejoinder would be that if the neuroanatomical basis of identity is a lot more robust than common wisdom claims, then autopsy does not necessarily need to interfere with preservation of the brain. There are a number of problems in this argument. If a cryonics patient would be recognized as being potentially revivable in the future, then the patient should no longer be considered a “corpse” that is subject to rules and regulations involving forensics or the disposition of bodies. Instead, a cryonics patient would be recognized as a terminally ill patient, or at least a subject with rights that prohibit mutilation or experimentation.

Another argument against autopsy is that conventional autopsy does not just involve the ongoing accumulation of damage associated with prolonged warm (or cold) storage but also involves invasive procedures that could mechanically injure the brain, including actual removal and dissection of the brain, and post-autopsy procedures that further accelerate the decomposition of the brain, such as placing it in the abdominal cavity where gastric fluids can accelerate damage. It is also not likely that a brain that has been subjected to autopsy, let alone removed and dissected, can still be perfused with a cryoprotectant to protect it against freezing. As a result, conducting an autopsy will almost invariably lead to a combination of additional damage to the brain and complete freezing.

## **The History of Autopsy**

The history of autopsy goes back to Ptolemy I of Egypt (367-283 BC) who was probably the first ruler to allow dissection of human bodies. In the early days of autopsy this mostly meant executed criminals. Herophilus (335-280 BC), “the father of anatomy,” routinely conducted autopsies on human beings and was one of the first contributors to the field of human anatomy. Other notable names include Galen of Pergamon (131-201 AD), author of ‘On the Usefulness of the Parts of the Body.’

During the renaissance, the study of human anatomy became more systematized but the actual autopsies were still performed by “dissectors” or “surgeons,” often on prisoners. The limitation of this division of labor is that physicians and students were mostly excluded from doing autopsies. Anatomy

professor Andreas Vesalius (1514-1564) broke with this separation of intellectual and practical research and conducted a large number of human autopsies, including studies late at night in the cemeteries of Paris. All this work culminated in the publication of his seminal work *The Seven Books on the Structure of the Human Body*.

During the 19th century autopsy became a routine part of research, medicine, and education. In Europe and the United States hospitals founded pathology departments, which were specifically tasked with gathering knowledge on disease and death. The pathologist Karl Rokitansky (1804-1878) performed more than 30,000 autopsies at the Vienna General Hospital.

The history of autopsy has not been without its share of controversy. In the 19th century occasional reports reached the press about supposedly dead people regaining consciousness upon the first cut of the scalpel. This and the related fear of pre-mortem burial provided ample materials for horror writers and the sensationalist press. As a result of these fears, more stringent criteria for determination of death and burial were developed.

Finally, as much as the practice of autopsy contributed to the advancement of science and medicine, early practitioners of both autopsy and medicine did not yet recognize the risks involved when they moved from dissecting a dead body to examining a live patient or even delivering a baby. The lack of hygiene enabled the transmission of diseases that killed thousands of patients. Ignaz Semmelweis (1818-1865) was one of the earliest advocates of hand-washing for surgeons and medical staff but was only vindicated after Louis Pasteur published his findings on microorganisms and provided a theoretical basis for Semmelweis's antiseptic recommendations.

In the medical and scientific profession the usefulness of autopsy is now widely accepted and in the 1950s autopsies were performed on almost 50% of all hospital deaths, a number that has declined to single digits in more recent times.

## **Autopsy Procedures**

Although a detailed understanding of autopsy procedures is unnecessary to prove the undesirability of the procedure for cryonics patients, it is useful to

provide context. An autopsy will typically start when the body and all the required paperwork (identification, medical records, consent forms etc.) have been received by the office of the medical examiner. In case there is a delay in obtaining records of the patient, or when there is a backlog of autopsy cases, the body is stored in a cold room or refrigerator.

While an autopsy is not a “sterile” procedure, pathologists and morticians will typically don protective gear to protect themselves against infectious diseases such as TB and prion diseases. Maintaining cleanliness can also be important to preserve forensic evidence.

The autopsy starts with an external investigation in which the body is weighed, measured, and photographed. During this procedure the pathologist performs a detailed inspection in which individual oddities and abnormalities are noted. In some cases, such as blunt trauma or liver dysfunction, skin color can already provide important clues about the cause of death. This part of the procedure also provides an opportunity to collect hair, blood, skin, and vitreous samples.

The external examination is followed by the internal examination in which a careful study of the inside of the body and individual organs is made. This procedure can also include the dissection of individual organs to inspect for signs of cardiovascular disease, cancer, hemorrhage, and other pathologies.

Of special interest to cryonics is the examination of the brain. In cases in which detailed inspection of the brain is required (stroke, gunshot wounds to the head, Alzheimer’s disease, etc.) the brain is removed from the skull. The standard procedure is to do this in such a fashion that the head and face can still be displayed to family during a funeral. A scalpel is used to make a cut in the scalp and the front and back skin flaps are pulled away to expose the skull. The top half of the skull is then removed by either a bone chisel or bone saw to expose the brain, which is covered in a hard layer called the dura mater. After removal of the dura matter and severing the vessels of the brain, the brain can be removed. After the brain is removed the surface of the brain can be examined and, if necessary, the brain can be dissected.

After the body and organs are thoroughly examined, the abdominal and thoracic cavities are sewn closed and the body is cleaned for further

processing (embalming or cremation). An autopsy report is created and tissue samples or organs may be stored.

A forensic autopsy is usually performed by a forensic pathologist or medical examiner with special education in forensics. There is a greater emphasis on determining the cause of death, the mechanism of death, and the manner of death. The investigation is not just confined to medical history of the patient but can also include collection of evidence from a crime scene.

From a cryonics perspective, the most challenging aspect of an autopsy is the examination of the brain. If brain removal is inevitable, the first mandate for a cryonics organization is to obtain some assurance that the procedure will be conducted at a low temperature. The second mandate is to prevent dissection of the brain. If dissection of the brain cannot be prevented, the best course of action is often to request chemical fixation of the pieces of the brain prior to shipping. It is important here to realize that there is no medical or forensic need for this practice and cryonics organizations should firmly discourage this, or even contest it.

## **Alternatives to Autopsy**

If the autopsy is focused on a specific part of the body and/or the examiner knows what (s)he is looking for (say, a bullet), a simple non-invasive investigation such as an X-ray, or a blood/fluid sample, or endoscopic procedure may be sufficient. For this reason it will always benefit the cryonics organization to have a good understanding of the aim of the autopsy and availability of alternative (non-invasive) procedures.

A more recent alternative for a full autopsy that is gaining in popularity is the virtual autopsy. Virtual autopsies are not only suitable in the case of religious or other objections to autopsy but also allow for modes of investigation and documentation that are not available in conventional autopsies. The use of virtual autopsies has been further strengthened by court rulings which, when confronted by a religious objection, mandate the use of the “least restrictive alternative” of achieving the government’s objective.

Virtual autopsy (or “virtopsy”) methods involve the use of noninvasive imaging technologies such as CT scans or MRIs to determine the cause of

death (or rule out other causes of death). Virtual autopsies can also be used in conjunction with toxicity reports or other kinds of evidence to allow for fact-finding without the use of traditional autopsy. Research has shown that in certain circumstances virtual autopsies can achieve comparable rates of accurate cause-of-death detection, or may even yield more accurate results. Virtual autopsies are also useful in cases where invasive procedures could alter or destroy evidence such as the detection of air embolisms in blood vessels.

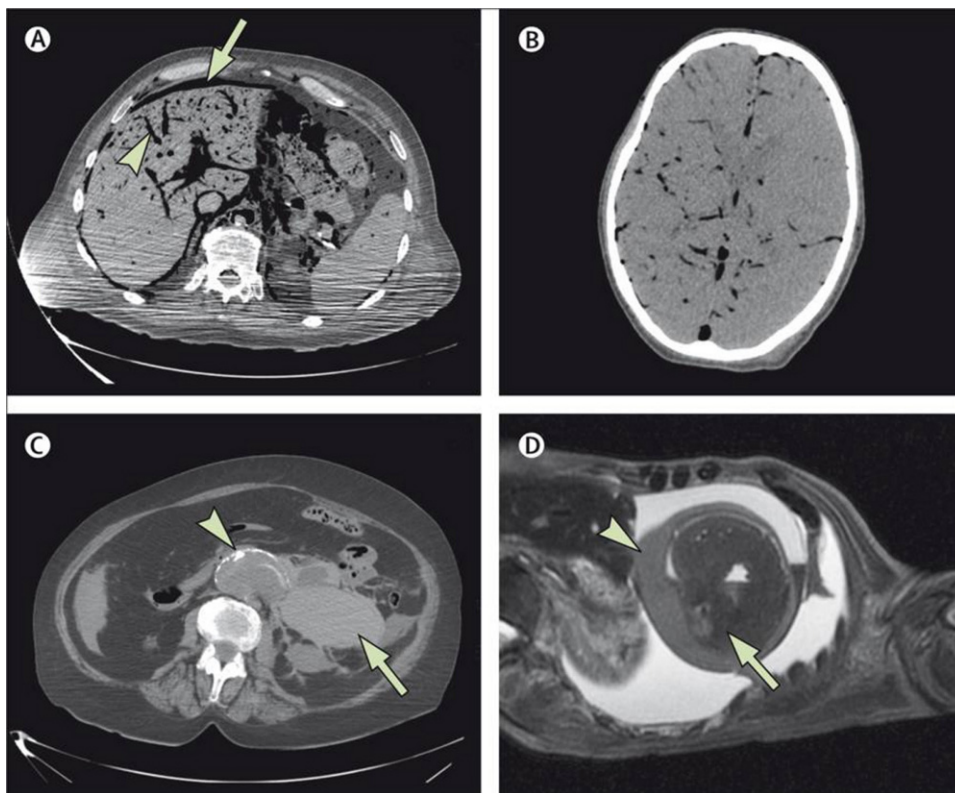

*Figure 5-3. Scans revealing decomposition and pathologies. A: Axial CT image through the upper abdomen showing extensive intravascular gas (arrowhead), in keeping with decomposition. B: Axial CT image through the brain showing extensive intracranial gas due to decomposition. C: Axial CT image showing rupture of an abdominal aortic aneurysm (arrowhead) with extensive retroperitoneal haemorrhage on the left (arrow). D: Oblique axial (short-axis view) T2-weighted MRI image showing a haemopericardium (arrowhead) due to rupture of a myocardial infarct (arrow). The Lancet. 2012 January 14; 379(9811): 136–142*

Notwithstanding these benefits, there are still a number of drawbacks to virtual autopsies. They are not equally effective for all kinds of examinations and are claimed to be inferior for detection of tumors, infections, and chronic conditions such as cardiovascular disease. In some cases, these limitations could be overcome by improvement of the technology or by using it in conjunction

The cost of virtual autopsy tables, MRI machines, and CT scanners may limit the number of cases in which virtual autopsy can be successfully requested or deployed. The use of a virtual autopsy may still require a court order, which can greatly increase the time the patient is at a (relatively) warm temperature, even if invasive procedures are ultimately averted.

The possibility of virtual autopsy constitutes an additional argument for members to overfund their cryopreservation, so that money will be available to cover the extra expense.

## **A Cryonics-Friendly Autopsy?**

In case it is evident in advance that the autopsy only needs to concern itself with the trunk of the body (for example, a dispute about the effects of a drug on the kidney), the cephalon of the patient can be separated and shipped to the cryonics facility on water ice or dry ice, depending on the elapsed time since pronouncement and temperature history of the case. This option is also available if a transport permit cannot be issued on short notice but the head can be transported as an organ rather than as a person. Even if the patient has requested whole-body preservation, cephalic isolation may still be the most desirable option to minimize damage to the brain.

Cases in which an autopsy seems inevitable often preclude doing stabilization procedures because the death of the patient comes unannounced or the standby team is prevented from getting access to the patient for forensic reasons. Even in such cases it is important to ensure that the patient is cooled as rapidly as possible. Cooling a patient close to the freezing point of water (but not below!) does not preclude routine autopsy procedures and can drop the rate at which (autolytic) damage incurs substantially. The best way to ensure that rapid cooling is being done is to send team members to the hospital

to observe, even if standard standby procedures are not permitted. For a detailed discussion of the physics and logistics of cooling, see section 11: Induction of Hypothermia.

The objective of quickly cooling the patient does not stop at the hospital or hospice but should continue while the patient is under the control of medical personnel or has been transferred to the medical examiner's office. At the same time, the patient should not be allowed to cool below 0 degrees Celsius, to prevent freezing damage. A cryonics organization must bear in mind that these requirements will be regarded as unusual by the medical examiner's office. Therefore, they should be emphasized repeatedly, especially if the patient is transferred to different entities or individuals before being surrendered to the cryonics organization.

If the cryonics organization is successful in keeping the patient cool prior to conducting the autopsy, the next objective is to ensure that the patient remains cool during autopsy. The most obvious method to achieve this is to surround the patient with ice. For most autopsies this should not be a problem because autopsy procedures can be performed at cool temperatures and the inspection of organs and tissues for medical and forensic information does not require normothermia.

The autopsy of a cryonics patient should be guided by the principle to do no unnecessary harm, especially to the brain. In practice this means that the autopsy should be limited to the areas of interest and that the rest of the body is left intact. If organs need to be removed it is important (particularly in whole-body patients) to return them to their original locations. If the brain needs to be inspected it is crucial that brain removal is conducted with more care than usual to prevent mechanical damage, and the brain should not be placed in the abdominal cavity. If dissection of the brain is really unavoidable, great care should be taken to ensure that all parts of the brain will be kept together. In such circumstances the best way to proceed (for both whole body and neuro patients) is to keep the brain separate from the rest of the body and ship it well protected on water ice (or dry ice) to the cryonics facility.

There can be circumstances in which it can be prudent to request that the body or brain is chemically fixed (embalmed). Usually, such a scenario would involve situations in which an autopsy is inevitable plus long delays are



expected. While chemical fixation may not be compatible with all medical and forensic investigations, it is compatible with some, and it could be beneficial to discuss this with the mortician or medical examiner. The chemical fixation approach is also suitable in case the brain has been removed from the skull and dissected to stabilize tissue before and during shipping. Research at cryonics-associated companies has even demonstrated that it is possible to conduct cryoprotective perfusion on a chemically fixed body. If the brain has been promptly perfusion-fixed or the parts of the brain have been placed in fixative, cryoprotection by immersion of the brain (or parts of the brain) in a cryoprotectant is still possible.

In all circumstances (including chemical fixation) it is important to insure that temperature of the patient remains as close to 0 degrees Celsius as possible. Even if an autopsy cannot be avoided, the depression of metabolism prior, during, and after autopsy can make the difference between damage and decomposition in the brain.

## **A Case History**

On February 14th, 2010, at approximately 10:30 am local time, Alcor member A-1712 experienced sudden cardiac death at his home in Florida. His case report at <http://www.alcor.org/Library/pdfs/casereportA1712DavidHayes.pdf> illustrates the power of a medical examiner to perform an autopsy despite strident objections and a clear indication of the preferences of the patient. At the same time, it demonstrates the ability of a cryonics organization to limit the injury that is inflicted.

A-1712 arrested in the presence of a friend, who called 911. Emergency personnel responded promptly and made an unsuccessful attempt at resuscitation. They called Alcor to notify the organization.

The patient was moved to Delray Medical Center where he was pronounced legally dead at 11:12 am local time. Alcor contacted the Medical Center and requested that the patient's head should be packed in ice.

There was no external sign of injury, but because the death was unexpected and was not preceded by any medical history that provided an obvious explanation, the Medical Center notified the medical examiner. By

the time a representative from Suspended Animation, Inc. (the local Florida service provider) reached the Medical Center, the patient had been moved to the medical examiner's office. By the time the representative reached the medical examiner's office, it had closed.

Alcor's attorney drew up a draft letter requesting that any autopsy should be limited, exempting the brain. On February 15th the medical examiner's office agreed on condition that it would retain the body, while the head could be released after a CT scan was performed using portable equipment at Alcor's expense. A court order was necessary to approve this procedure.

Because of delays related to a national holiday, the court order was not delivered to the medical examiner's office until February 17th. The portable CT scanner could not reach the office until after working hours, so a representative from Suspended Animation was authorized to drive A-1712 to Columbia Hospital where the scan could be carried out. After a review of the scan by a radiologist, Suspended Animation was allowed to perform cephalic isolation so that the patient's head could be transferred to Alcor for neuropreservation.

The head was packed in dry ice in a container suitable for air shipment. Around noon on February 18th the head was at a temperature of -64 degrees Celsius in 20 lbs. of dry ice. The patient was placed on a flight departing from Fort Lauderdale at 7:05pm local time.

A-1712 endured at least 72 hours without cooling to near 0 degrees Celsius, despite prompt notification of the cryonics organization and efforts to prevent the autopsy. A court order was required before personnel at the medical examiner's office were willing to deviate from their usual procedure, which would have been to include dissection of the brain.

The case raises issues about sudden death generally. Even if an autopsy had not been required, the patient would have been in circulatory arrest for a considerable period of time before a standby-transport team reached him. In addition, clearly there is no substitute for team members going to the hospital or mortuary in person, to insure that Alcor's cooling instructions are actually followed and maintained. Hospital staff and mortician staff may be willing to implement basic Alcor procedures but will not have the sense of our urgency or specific knowledge to insure rapid cooling.

Still, these factors are relatively trivial compared with the power of a medical examiner to take possession of a patient and perform a forensic autopsy regardless of statements of religious (or nonreligious) belief.

An autopsy remains one of the worst things that can happen to a cryonicist.

## **6. Deployment Issues**

### **Before Deployment: Readiness**

Cryonics training and reference manuals have traditionally assumed that all necessary equipment for standby, stabilization, and transport will be immediately available when team members need it. Manuals have concentrated on procedures, omitting any description of prior preparation that enables the procedures to be performed.

The task of maintaining readiness is mundane and pedestrian but should not be overlooked or trivialized. An organization that provides standby response should have at least one person on staff who is primarily tasked with ordering, assembling, inventorying, and packing the dozens of pieces of equipment and hundreds of components, tools, and supplies that are involved. This person must devote scrupulous attention to detail.

No standby team should ever open a transport container and find that something was omitted by accident—or was borrowed by a person who forgot to put it back.

### **Inventory and Identification**

The first step in building a standby/stabilization/transport kit is to translate the protocol of a cryonics organization into an inventory of items that will be required. Ideally at least three people should reach a consensus, including one with extensive practical field experience, one with a strong technical background, and one who is intimately familiar with the current inventory. Significant upgrades should be discussed extensively and should never be implemented until feedback has been received from all people who will be affected—especially team members. At the same time, the expiry dates of medications must be tracked so that meds are replaced when necessary.

No matter how well a kit is designed, case simulations at cryonics organization show that it is almost impossible to create a set of standby kits (or the interior of a vehicle) that can satisfy everyone's requirements and can be used effectively without practice and modification. Periodic training sessions are essential to avoid situations in which time is lost in searching for something trivial like a tubing connector or set of instructions.

After a standby/stabilization/transport kit has been developed, the organization must resist two conflicting temptations:

- To imagine that the kit is “finished.”
- To allow it to be modified whenever someone comes up with a new idea.

To damp the oscillations to either of these extremes, as many people as possible should be involved in the decision process. This is one of the few areas in cryonics where some inertia is desirable.

Containers should be sealed to discourage anyone from borrowing parts or components from them. They should be numbered or otherwise identified with the following priorities in mind:

- Use large numerals and/or letters, easy to read from a distance.
- Use an obvious numeric or alphabetical sequence, so that the absence of a container is immediately noticeable, especially when pulling them hurriedly off a baggage carousel.
- The identification scheme should be flexible enough so that new containers may be inserted in the sequence if they are needed to accommodate additional standby items.
- If some containers are for mortuary only, and others are for bedside only, color coding should be used to make this immediately obvious. (The option to divide containers between bedside and mortuary is described below.)

Any numbering sequence should match the sequence of events that typically occurs. The first container of a series may store a mechanical

cardiopulmonary support device, with accessories and airway management items. The second container may store medications and IV supplies—and so on. This may seem obvious, but both authors have seen standby kits in which little consideration was given to this principle.

## **Replication**

Any organization that has control over standby procedures will usually want at least two kits, so that one will be immediately available while the other is being refurbished after a case.

We suggest that one kit should be considered as the master, or primary, while others are secondary. The secondary kits must be exact replicas of the primary. Any change to the primary must be propagated immediately through the secondaries, to honor this fundamental rule:

All kits must be exactly the same, so that personnel who have been trained to use one set of equipment will always find exactly the same set, stored identically.

Similarly, one inventory reference list should be primary, while all others are considered secondary and copied from it. This will also affect inventory pages placed inside each container.

In the past, Alcor maintained regional standby kits distributed around the USA among groups of volunteers who might provide an immediate local response. Keeping track of the inventories of these kits, including medication expiry dates, was a major challenge. While we believe there are significant advantages to regional standby kits, maintaining them will require careful thought if this system is ever reinstated.

## **Comprehensive vs. Small-and-Simple**

Historically we have seen tension between two philosophies regarding the inventory of standby kits:

Those who advocate *Small-and-Simple* kits prefer to minimize the number of containers and the diversity of the inventory, believing that team members will be more easily trained and may work more quickly and efficiently if they are not confronted with a huge and confusing array of items. The team members may still be able to improvise if they lack exactly the right tool for the job.

Those who advocate *Comprehensive* kits believe that transport containers should include equipment to deal with every conceivable scenario, to minimize the risk of a case turning out badly because the right tool for the job wasn't available.

We acknowledge that large inventories and a wide range of supplies can seem daunting, can be more vulnerable to inventory errors, and will incur greater costs during preparation, deployment, and restocking. However, in our opinion, if an elaborate standby kit seems insufficiently user-friendly and compels team members to search numerous boxes and containers for the items they need, this simply means that the kit was not well designed. The answer is to rethink its packaging, not make it smaller.

Comprehensive standby kits can be, and have been, organized in a systematic and logical fashion, grouping equipment by type so that it is easily retrieved, and color-coding labels so that they are easily recognized. Conversely, even a small and simple kit can be made counter-intuitive, difficult to use, and can become an unorganized mess if no thought is given to how the equipment and supplies are packed. Worse, the desire to cram everything into a few containers can make equipment harder to locate and extract.

## **Sequential vs. Parallel Organization**

If a purpose-built vehicle is unavailable for a case, stabilization activities can be divided into two groups: *bedside* and *mortuary*. The bedside procedures include all the initial interventions, after which the patient is usually

transported to another location, such as a mortuary, to be placed on bypass for blood washout and substitution.

Traditionally, preparations have been made sequentially. All equipment is taken to the bedside initially. All equipment then moves with the patient to a location such where blood washout will occur, and the patient must wait for setup of the perfusion equipment. Surgery may take place while this is being done, but setup can easily take longer than the surgery. Forcing the patient to wait is highly undesirable, since rapid cooling on bypass is so potentially advantageous to minimize cellular injury.

In the parallel method for preparations, equipment is divided into two sets of containers. The first set goes to the bedside while the second set goes immediately to the mortuary, accompanied by a team member who will set up the perfusion circuit in advance, so that it is ready when the patient arrives. The team members at the bedside will lose the help of the team member who has gone ahead to the mortuary, but the patient will endure less waiting time. If this option is chosen, equipment must be divided very carefully between the bedside containers and mortuary containers, and some duplication may be necessary. For instance, scrubs must be included in both sets of containers.

Overall, having discussed this issue extensively and having reviewed cases which used either one scenario or the other, we believe the parallel model has advantages, although we prefer to see it used when at least four personnel are available.

## **What Can Go Wrong**

When a team is sent out into the field with a set of standby-stabilization-transport containers, they begin in a situation full of unknowns, where they have little control over the many variables. Their task is to bring the situation gradually under control, to the point where the patient is solely and entirely in their care. The goal of a deployment is to manage this process as rapidly as possible, with a minimum number of errors.

Of course, errors may still occur. Here is a partial list of some that we have seen in actual cases:



- Expired or cancelled member funding
- Other financial irregularities (e.g. patient's suicide invalidates life insurance)
- Simultaneous standbys for two patients; insufficient personnel
- Key personnel on vacation, attending a conference, or out sick
- Patient in a remote or inaccessible location, or foreign country
- Difficulty locating a cooperating mortician
- Insufficient available seats on airline flights
- Too much baggage; some equipment delayed till a later flight
- Weather-related delays
- Missed connections
- National holiday preventing car or van rentals
- Team has difficulty finding patient location
- Hostile relatives or medical personnel
- Patient changes his or her mind, doesn't want cryonics
- Patient legally dies before team arrives
- Medical condition (e.g. pneumonia) conflicts with procedures
- Unable to deploy equipment near patient
- Unable to bring an ice bath into building or room
- Unable to get promptly signed death certificate
- Difficulty pushing medications
- Equipment failures
- Dislodged thermocouple wires

- Temperature logger wrongly set or not started
- Difficulty cannulating fragile blood vessels in elderly patient
- Perfusion problems; lack of flow; edema
- Insufficient ice
- Ice melted during a multi-day standby, was not replenished
- Dry ice unavailable in the standby location
- Patient too large for standard shipping container
- Unable to get transit permit from county in a timely manner
- Airline problems affect transport of patient

The bad news is that for a case to be judged successful, all of these problems (and many more) must be avoided. In other words:

**Usually there is only one way for a case to turn out well.**

**There are countless ways for it to turn out badly.**

The good news is that all of the problems listed above can be avoided. The question is how best to achieve this.

## **The Role of a Coordinator**

Sending a standby team out to a remote location is like launching a spacecraft to the moon. The team members must take with them almost every little thing they need, from syringes to spare underwear, and must be capable of improvising repairs if necessary.

The lunar astronauts relied on advice, planning, and directions from Mission Control. Likewise, we believe that a standby team should rely on a “coordinator” (the actual job title may vary) who remains back at the cryonics organization where he has reliable communications and can oversee the case

as it progresses. Running a case remotely may seem counter-intuitive, but the people who are participating in hands-on procedures will have difficulty retaining objective detachment, and may not have time to make phone calls to set up car rentals, find out where the mortician is, or check airline schedules.

The team leader will be on-site at the standby, and will retain authority to make on-the-fly decisions at that level, but the coordinator must have the ultimate authority to make logistical and procedural decisions. While this seems to place the coordinator in a controlling role, he also acts as a servant to the standby team, insuring that anything and everything they need has been foreseen and is immediately available to them. Meanwhile the directors or senior management of the organization will retain the authority to authorize a standby, cancel a standby, and resolve financial or legal issues.

The coordinator will perform the following tasks:

1. Select the members of the team based on personal knowledge of their past experience, their skills, and their mutual compatibility.
2. Maintain liaison with directors or senior management of the cryonics organization, to insure that decisions are properly approved and will not have to be reversed later.
3. Maintain communication with one or more medical advisors, so that they know the current status of the patient and can give properly informed advice.
4. Have immediate access to all patient documents and a fax machine, so there will be no delays on-site caused by lack of legal authorization. Maintain access to a complete patient health history.
5. Have a complete list of the contents of all containers in the stabilization kit, so that in unforeseen circumstances, workarounds can be suggested using existing equipment.
6. Maintain frequent communication with sources of information in the field, so that decisions are properly grounded in reality. Information sources will include the patient (if still conscious), the primary care physician, any key relatives (especially any who have durable power

of attorney for health care), the leader of the standby-stabilization team, a cooperating mortician, and (ideally) cooperating nurses who will often have more timely information than people higher up the command chain. Naturally the coordinator may choose to delegate some decisions to the team leader where this seems more appropriate.

7. Maintain online access to airlines and their schedules and regulations, vehicle rental companies, sources of overnight lodging, local suppliers of welding gases, and maps of the area where the case is taking place, so that the coordinator can line up everything that the people in the field will need before they need it.
8. Attempt to make contact with the local county coroner or medical examiner if there is any risk of autopsy.
9. Be aware of the next procedure or event during the case, and arrange human resources and equipment to be ready, with contingency plans for failure.
10. Respond to problems that do occur, and suggest solutions.
11. Track the position and activity of each team member, and the location and current status of the patient.
12. Make sure that the cryonics organization will be ready to begin surgery and cryoprotective perfusion as soon as the patient arrives.

One of the authors (Platt) has participated in 21 cases. In six of them he played the role of coordinator.

## **Deployment Committee**

In light of the previous points, it should be clear that the decision of when and how to deploy can be a source of uncertainty and disagreement. One way to remedy this situation is to form a deployment committee which includes persons with different kinds of backgrounds and knowledge to ensure that all relevant information is being taken into account.

For example, a deployment committee can consist of the following people:

- The CEO of the cryonics organization, to insure that the strategic goals and priorities of the organization are given due consideration.
- A medical professional who has extensive experience in assessing critical patients and its consequences in terms of protocols and equipment.
- The transport coordinator or team leader, to insure that decisions are made with accurate factual knowledge about the availability and skills of team members and equipment needs.

Ideally, such a deployment committee meets to decide (by majority vote if necessary) when and how to deploy. The committee should not only specify the rules for normal decision making but also specify rules for circumstances in which not all members can participate in decision making or, in cases of extreme emergency, when decisions need to be made without delay in the field.

Clearly, a deployment committee cannot anticipate or cover all aspects of a deployment but it should be expected that when such a committee has been active for a considerable period of time general lessons have been learned which will enable the committee to operate in a more rule-bound fashion without making up decisions on the fly.

For example, in 2009 Alcor Life Extension Foundation formed a deployment committee consisting of the Executive Director, the Chief Medical Advisor, and the Transport Coordinator.

## **Deployment Decisions**

### *The First Phone Call*

One of the most difficult decisions for a cryonics organization is whether to mount a standby, and if so, when to initiate it. Early information about a potential case may be fragmentary and inaccurate. It may take the form of a

single phone call from a distressed relative in the middle of the night. The person who receives the initial phone call should be briefed to ask these questions and make a clear record of the answers:

- Please give me your phone number (in case of disconnection) and your name.
- Are you the patient? If not, what is your relationship?
- If you are not the patient, is the patient still alive?
- Is the patient a member of this organization?

The remainder of the call will depend on the answers to these questions and the policies of the cryonics organization. Four basic situations are possible:

**1. Patient is legally deceased and is not a member of the organization**

A cryonics organization may be willing to accept this type of case under exceptional circumstances—for instance, if death occurred from natural causes, only an hour or two ago, and verifiable funding is immediately available. The phone call should be transferred to someone in the management of the organization who can make such determinations.

**2. Patient is legally deceased and is a member of the organization**

The organization must check the sign-up paperwork to determine the patient's preferences. Many people insist on being cryopreserved even in situations which seem hopeless. In such cases the organization has an ethical obligation to retrieve the patient, and may even seek to disinter the patient if burial has already occurred. On the other hand, some cryonicists (a minority) may allow the organization to “give up” if the situation seems hopeless.

**3. Patient is alive and is not a member of the organization**

This case is now classified as a “last minute case” (even if the patient still has weeks to live) because the patient (or a relative or friend) has chosen to make cryonics arrangements after the patient has already become terminal. In this

situation, no funding will be in place to pay for deployment of a standby. If the caller is speaking on behalf of the patient, the organization will need to determine whether the caller is representing the wishes of the patient accurately. If the caller is the patient, the organization must make sure that the patient is competent to make decisions and has a rational understanding of the limitations and experimental nature of cryonics. Either way, all documentation and funding must be received and verified before a standby will be attempted.

#### **4. Patient is alive and is a member of the organization**

This case may now call for a standby, and should be considered potentially urgent. The telephone conversation may continue with these questions:

1. What is the patient's medical condition?
2. Is the patient conscious and rational?
3. What is the prognosis? How near is the patient to death?
4. What is the patient's location? (Get specific details, including hospital or hospice name, street address, and phone.)
5. Who is the primary care physician? How do we contact him?
6. Does anyone have durable power of attorney for health care? (If so, we need to know how to contact that person.)

At this point, if the person receiving the phone call is not qualified to play the role of coordinator, he should keep the line open (if possible) while contacting the coordinator or senior management of the cryonics organization. The call can then be transferred to someone with decision-making authority. Either way, someone should immediately check the member's paperwork and account to address the following questions:

1. Do we have all necessary signup documents?
2. Do they contain any special requirements or provisions?
3. Is all the necessary funding in place?

4. Are there any special circumstances which could interfere with funding?

If the paperwork checks out, the next step is to decide when a standby should be initiated.

*Initial Assessment*

If time permits, one individual (usually, the team leader) should go out to make an initial assessment and gather more data.

An initial assessment should include the following:

- Location of patient: Home, hospital, home hospice, hospice?
- Available parking, cost, maximum height (OK for transport vehicle?)
- Permission to deploy equipment?
- Obstructions to equipment (stairs, elevators, small spaces, narrow hallways)
- Names of physicians, nurses, administrators
- Who can pronounce legal death? Who can sign a death certificate?
- Names of family members, friends, others who are involved
- Anyone who has a strong interest (positive or negative) in cryonics
- Name of patient's attorney, if any
- Mental state of patient: Conscious or comatose?
- If conscious: Able to make decisions? In denial, anxious, sedated?
- Health care issues: Blood thinners? IV line? Circulatory problems? Pneumonia?
- Contact information for coroner or medical examiner



- Location of county health department, and hours of business
- Paperwork needed to transport out-of-state
- Other regulations
- Closest mortuary to patient's location
- Cooperativeness of mortician/funeral director
- Size, convenience, cleanliness of prep room (if it may be used)
- Mortuary fees
- Does the mortuary have an appropriately sized Ziegler container?
- Nearest airport, car rental, van rental, welding gas supplies
- Nearest hotel/motel, 24-hour source of ice, sources of quick food

The team leader should return from the assessment with a map of the primary locations, a list of names and phone numbers, and personal observations about the helpfulness of the people whose cooperation may be needed.

The team leader may also discuss with the coordinator the possibility of moving the patient to a better location, if this seems advisable and if the patient and family members are willing.

### *Air or Ground*

The standby team and equipment can be deployed via a ground vehicle, a scheduled airline, or both. As a rule of thumb, a ground vehicle may have advantages if the distance of the patient from the organization is 1,000 miles or less. Assuming a very conservative average speed of 55 miles per hour, a vehicle should be able to bring a patient back to the facility within 18 hours. This is within the preferred 24 hours which has been recommended for transport in water ice after perfusion with MHP2 organ preservation solution. While an airplane may theoretically enable much faster transport over a 1,000-mile distance, the actual flight time may be unimportant compared with time penalties that air travel often imposes. Here are two hypothetical scenarios:

**Optimal Air Transport Scenario**

This is the kind of scenario which people tend to have in mind when they imagine air travel.

Mortuary very close to airport. Transit time:	0.5 hours
Mortuary is recognized by airline. Paperwork time:	0.5 hours
A convenient flight is available. Waiting time:	1 hour
No weather delays or mechanical problems	0 hours
Flight time, 1,000 miles	2 hours
Taxiing time, unloading time	0.5 hours
Receipt of patient and drive to facility, no heavy traffic	1 hour
Total time, mortuary to cryonics facility	5.5 hours

**Suboptimal Scenario**

Unfortunately, this scenario is much more likely:

Mortuary far from airport, or bad traffic. Transit time:	1.5 hours
Mortuary has no prior relationship with airline. Paperwork:	2 hours
All flights have gone for the night. Waiting time:	6 hours
Bad weather delays or mechanical problems	2 hours
Flight time, 1,000 miles, delay caused by traffic control	2.5 hours
Taxiing time, unloading time (busy airport)	1 hour
Difficulty finding patient in freight section of airport	1 hour
Pick up patient and drive to facility through heavy traffic	2 hours
Total time, mortuary to cryonics facility	18 hours

Of course, not all of the factors in the suboptimal scenario are likely to occur on the same day. On the other hand, the suboptimal scenario could be much worse. A nonstop flight may be unavailable, forcing a connection that may add a significant time penalty. A holiday season or very bad weather could impose a delay lasting for a full day. An airline may refuse the patient

altogether if a transit permit or other paperwork has not been filled out correctly.

By comparison, the only significant cause of delay for ground transport would be mechanical problems affecting the vehicle. So long as the vehicle is properly maintained and relatively new, such problems should be rare.

The dilemma for the cryonics organization is:

- Should we try to bring the patient in faster by air, taking an unknown risk that there may be some delays?
- Should we play safe and use the ground vehicle?

Note that any problems affecting the ground vehicle will be under the control of the cryonics organization, whereas issues affecting air travel will not be under the control of the cryonics organization. Remember always that the goal of standby-transport is for the organization to acquire as much control over the patient as possible.

Similar considerations will apply if the patient is very near death, and the cryonics organization is trying to determine the fastest way to deploy team members to the patient's location. In this scenario, the organization must consider possible air-travel penalties such as:

Driving equipment to the airport (average traffic)	1 hour
Checking in at airport with a big pile of excess baggage	1.5 hours
Possible flight delay	0.5 hours
Flight time	2.0 hours
Taxiing time and waiting for bags at carousel	1.0 hour
Picking up a rented van	1.0 hour
Driving van from airport to hospital (average traffic)	1.0 hour
Total time, cryonics facility to hospital	8.0 hours

This still looks good compared with a ground transport time of 18 hours, but it depends on a suitable flight being almost immediately available. Also, as airlines attempt to load their flights as efficiently as possible, it is quite likely

(perhaps a 1 in 4 chance) that the airline will refuse to accept all of the standby equipment as excess baggage for the first available flight. Some items may be delayed by several hours, for the next flight. The team will then have to return to the destination airport to pick up the delayed items.

In addition, if a team flies in, it will have to rent a van which will have none of the amenities of the cryonics organization's ground vehicle. Typically it will have no side windows, only one dim light in the load area, and limited means to tie down cargo. There will be no seating in the rear. If team members want to save time by drawing meds on their way to the hospital, they may find themselves doing so under very difficult conditions.

Perhaps most importantly, a ground vehicle that has been converted for standby use by a cryonics organization may enable surgical procedures, thus eliminating a run to the mortuary when the patient has not yet been fully cooled.

If all of these factors are considered, the ground vehicle looks attractive (compared with scheduled air carriers) for a deployment of 1,000 miles or less. Even in an emergency situation, the ground vehicle can still be sent out as backup for team members who fly ahead with stabilization equipment. The vehicle still may arrive in time to be used for blood washout. After stabilization procedures have been completed, the team can decide whether to bring the patient back in the vehicle or, if air travel looks good, they can take the patient to the airport.

Research into the use of organ preservation solutions during transport of cryonics indicates that better results can be obtained by continuous or intermittent low-flow perfusion of the solution. Obviously, these protocols are impractical, if not impossible, during air transport. Future developments in cryonics protocol may place more emphasis on maintenance of brain viability instead of simple cold storage.

### *Selection of Team Members*

Based on personal experience and extensive study of case reports, *we believe that at least four people are needed to manage a remote standby followed by stabilization.* Typically, if the standby lasts for more than 12 hours, two people will sleep while the other two remain awake, in 12-hour shifts.

Ideally the four people should share the following skills and experience among them:

1. Leadership, decision-making based on experience
2. Able to assess and understand the condition of a living patient
3. Draw medications in correct dosages
4. Raise a vessel in a patient with no blood pressure, and set an IV line
5. Intubate an unconscious patient
6. Set up, run, and monitor mechanical chest compressions
7. Place thermocouple probes, initiate and check automatic data logging
8. Take notes either verbally or by hand
9. Create a photographic record in stills or video
10. Drive vehicles and read maps competently under stressful conditions
11. Perform femoral cutdown
12. Cannulate vessels, run perfusion equipment
13. Pack the patient for shipment
14. Sufficient physical strength to move, unpack, and pack equipment

In addition, all team members should be available at any time (day or night), punctual, able to manage stressful situations, resourceful, and likely to create a good personal impression on everyone from relatives to hospital administrators.

No wonder standby work is so hard! How can a cryonics organization find four people who share all of these attributes?

### *Amateur Assistance*

In the early days of cryonics, all standbys were staffed almost entirely by unpaid volunteers who had received varying amounts of basic training. This

system was feasible because cases occurred seldom, participation was regarded as a special privilege, and regional groups encouraged people to get involved. Two key personnel (Mike Darwin and Jerry Leaf) possessed the surgical skills and the ability to run perfusion equipment for blood washout, respectively. These individuals basically told everyone else what to do.

After the untimely cryopreservation of Leaf, Darwin established his own service provider, BioPreservation, Inc, which attracted a series of employees with varying skills, knowledge, and interests. But cases still depended largely on assistance from people who did not have medical qualifications. This situation continued through the 1990s and into the 2000s, and became a source of criticism from observers who felt that cryonics should be “professionalized.”

In the skills/experience list above, clearly 6, 7, 8, 9, 10, 13, and 14 can be performed by people who have relatively little training.

In fact we feel there is a very strong need to revitalize regional groups and encourage members of cryonics organizations to get involved, assuming they can satisfy basic criteria. The imperfect data logging, lack of written notes, and lack of visual records in most cases during the past 20 years suggests that a great need exists for personnel who can perform these relatively simple tasks, and they do not need medical qualifications.

Volunteer help obviously has its limits. For example, we doubt that volunteers can draw medications reliably, and we question the usefulness of training them to do so. Still, we feel strongly that cryonics organizations should consider reverting to the former practice of inviting volunteer participants to take care of routine tasks. As a side benefit, the volunteer participants will undergo an apprenticeship that may lead them into a more active role and even a career in cryonics.

Note that the most effective intervention to prevent ischemic injury and perfusion impairment is cooling. Unlike other tasks such as placing an IV or airway, cooling does not require any special skills, just a basic understanding of heat transfer. Some cooling methods are more effective than others but even the more effective methods to induce hypothermia (such as the use of a circulating ice-water bath) should not present major challenges for volunteers with some basic training. Only the most advanced cooling methods (liquid

ventilation and internal cooling by extracorporeal perfusion) require advanced skills.

It should also be noted that no amount of knowledge and skill can substitute for good diplomacy and common sense.

*Full-Time or Contractor?*

Another debate has centered on the choice between hiring full-time staff or using independent contractors to perform procedures where training is essential, such as administering medications, intubation, perfusion, and surgery. Some of the pros and cons can be summarized in the following table:

	Advantages	Disadvantages
Full-Time cryonics employee	Reliably available for cases (except on vacation/sick days). Long standbys okay. Highly motivated. Good candidates for in-depth training (if they stick around). A long-term investment.	Lengthy hiring process. May see cryonics as career killer. Unreasonable expectations? Cost of wages, benefits. What do they do when they aren't doing standby work? Skills may atrophy.
Contract help such as EMT	Easily found and replaced. "Just a job," no expectations. In their day jobs, they maintain and use skills on a daily basis. Paid only when doing a case (plus maybe a retainer).	No guaranteed availability, may not show up at all. Standby for 3-4 days max. Motivation level unknown. No time or interest for in-depth cryonics training.

We note that while advocates of full-time help often claim that an employee will be "always available," this is not really true. Suppose an employee is willing to be on-call 24 hours during every weekday and half of the weekend days in a year. That will be approximately 310 days. Now deduct 20 vacation days, 5 national holidays, and 5 sick days, to get a net availability of 280 days out of 365. This represents a 77% availability. In other words, even in an optimistic scenario where employees will respond in the middle of the night,

we cannot really expect them to be available for more than three-quarters of the times when we need them for standby work.

Also, the lengthy hiring process for a full-time candidate is likely to be difficult. One of us (Platt) reviewed at least 1,000 resumes in the course of trying to fill one senior position in a cryonics organization. The cumulative time spent assessing resumes, making phone calls, and interviewing candidates is significant.

Also, even a successful candidate may turn out to have problems. Few MDs or surgeons, for instance, see cryonics as a smart career move; thus most candidates are unconventional and may have “problem resumes” or past embarrassments which they will try to conceal from the interviewer. In one instance familiar to us, a job candidate who seemed ideal for a cryonics organization turned out to have a criminal record under a different name. This was not discovered until a year after she was hired.

For various reasons, fewer than half of the medical professionals who have been hired into cryonics have stayed for more than a year. Consequently, all the time that was spent on hiring, training, and orientation of these employees was wasted.

Another problem is that cryonics tends to attract employees who have unrealistic expectations, since they assume that the field has huge growth potential from which they may benefit personally, either in status or financially. They may also see themselves playing a very significant role in an idealistic movement out at the cutting edge of medicine, and will be disappointed, and sometimes angry, when they fully understand the limited resources available for cases and the amount of routine drudgery involved.

When unrealistic expectations are destroyed, a formerly enthusiastic employee may become an angry or even vindictive ex-employee.

Most problematic of all, a surgeon, paramedic, or EMT has skills which are normally practiced and reinforced on a daily basis. At a cryonics organization, cases requiring field work may occur only a few times a year. Action-oriented EMTs may become restless after weeks at the office, and may have little tolerance or aptitude for detail work such as stocking standby kits and maintaining a precise inventory. Someone with surgical skills may feel like a frustrated concert pianist who only gets to touch a keyboard every two



months or so. If the cryonics organization can support an active animal research laboratory, the surgeon can use his skills there; but an animal lab must satisfy demanding regulations, must employ people to care for the animals, must have a defined and rational purpose, and may raise the risk of attacks by activists.

The alternative, of course, is to have a surgeon on call as an independent contractor. Since surgeons typically have busy schedules, a retiree is ideal, but may not be willing to endure the rigors and deprivations of standby work.

### *Surgeon or Mortician?*

If cases should involve blood washout (which we strongly advocate unless there are specific contraindications), there is an inescapable need for at least one person who can make an incision, raise, and cannulate femoral vessels. Fortuitously, morticians perform this task on a daily basis when they need to perfuse patients with embalming fluid. The question is whether morticians should be allowed to perform this procedure on cryonics patients.

One of us (Platt) witnessed a demonstration of surgical technique by a mortician in Phoenix, Arizona which was impressive, since he took less than 30 seconds to raise a femoral vein. But morticians are accustomed to thinking of their patients as “dead,” and if a small vessel is nicked or cut, they may not see some minor leakage of embalming fluid as a serious issue. In cryonics cases where cryoprotective perfusion will be required, nicking a blood vessel is not a trivial matter.

The typical mortuary technique involves a deep and rapid incision with a scalpel, followed by insertion of hooks which raise the vessels. By contrast, surgical technique involves blunt dissection to expose a blood vessel, which is then carefully isolated and inspected for branches that may be hidden. This procedure may take half an hour or more.

Another difference between surgeons and morticians is that morticians are not accustomed to working in conditions where blood clotting is inhibited, and actual blood pressure exists because cardiopulmonary support is being performed or has only recently stopped. Unlike cadavers being prepared for embalming, surgical fields of cryonics patients can quickly fill with blood.

Is a slow and painstaking surgeon preferable to a fast but perhaps less detail-oriented mortician? This question has never been adequately answered, in our opinion, especially since levels of skill will vary among both surgeons and morticians.

If a cryonics organization wants to use its own surgeon, the full-time or part-time dilemma described above is problematic.

### *Emergency Medical Skills*

In 2003, Alcor Foundation contracted with a group of paramedics and emergency medical technicians (EMTs) to participate in cryonics cases. These personnel said that they would be able to take two or three days to participate in a case, by swapping their schedules with others in their ambulance or fire companies. Unfortunately, a bout of negative publicity concerning Alcor in 2003 ended this contractual arrangement before the personnel did any cryonics work.

Alcor also contracted with the principals of a paramedic/EMT training facility in South Florida. Two EMTs and one paramedic associated with this company participated in at least three Alcor cases during 2004 and 2005. The results were generally good, but would have been better if Alcor had provided more active supervision.

Suspended Animation, Inc. contracted with the same South Florida training facility, and added more paramedics and EMTs in an effort to create a pool of 10 people who could be called in an emergency. Several training sessions were conducted, and some of the personnel seemed seriously interested in doing cryonics work. Yet when a case finally occurred around 10 pm on a Friday night, *not one* of the EMTs or paramedics was able or willing to respond. One had just been in a car accident; another said he had the flu; two had conflicting work obligations; and others didn't even answer their phones.

What about full-timers?

Alcor hired a paramedic as a fulltime employee in 2003; but this individual expressed disenchantment with the organization and with cryonics generally, and quit in a flurry of recriminations. Alcor hired another paramedic to replace him, who amiably participated in training courses but

showed little serious interest in cryonics and eventually left to become a naturopath. Alcor then hired an EMT who was very serious about cryonics, but left as a result of personal issues. Alcor then hired yet another full-time paramedic, who worked very actively and was a great asset to the organization.

One lesson of this experience may be that an organization must be willing to make multiple attempts to find the right person.

Hiring people for office or workshop work, and then hoping to motivate them to acquire skills relevant to case work, is obviously a gamble, and the investment in EMT training will be wasted if there is high employee turnover. On the other hand, at this time, we feel that the strategy of training existing employees has proved more reliably successful than other strategies. It also creates the possibility of accumulating more skills over time, so that employees can substitute for each other. Multiply competent people should be the ultimate goal to achieve redundancy in case work.

We conclude that at this point in the evolution of cryonics, there is no definitive answer to the problem of maintaining a team with good, well-practiced, reliable medical skills, but on-the-job training should be considered as a serious option.

### *Members or Nonmembers*

A closely related topic is whether to employ staff members who have not made personal cryonics arrangements. The obvious advantage of people who have made cryonics arrangements themselves is that they recognize a close link between their efforts to deliver good care (and improve procedures) and their own fate. The disadvantage is that “cryonicists” often have few relevant skills to offer, at least initially, beyond their commitment to the field. On the other hand, not all aspects of cryonics are a simple translation of existing medical procedures and there is a strong need for people with a comprehensive technical understanding of human cryopreservation.

During the 1990s, when the concept of using professionally qualified nonmembers was first explored seriously, many people were concerned that nonmembers would not “try hard enough” to perform procedures on a person whom they believed was permanently dead.

Now that noncryonicists have participated alongside cryonicists in numerous cases, we find that the anxieties were unwarranted. All team members appear to have worked equally hard, trying to make the case a success according to the criteria which they have been taught. Naturally the results will be better when a team member is a hard worker who wants to prove himself, but this is true in any activity.

Provided a coordinator has had some personal dealings with the people available for a case, he should feel no concerns about using those who have not signed up for cryonics.

### *The Final Mix*

The final mix of team members will be determined by the coordinator at the time when the standby is mobilized. To some extent this will be influenced by pragmatic factors, such as who happens to be available. But the coordinator should strike a balance between experienced team members who have worked often together, and new people who will benefit from field experience.

We feel it is a very bad idea to restrict the number of people on a standby. Four is an absolute minimum. The human costs associated with a standby (such as air fares and lodging) are usually modest compared with other expenses (such as medications, other consumables, equipment transport, mortuary fees, and employee time for cleaning and restocking a standby kit). Every standby should be an opportunity to educate newcomers as well as utilizing the skills of people with experience.

## **Ready to Roll**

Maintaining standby equipment in a ready state should be a simple task, yet experience shows that on a depressing number of occasions, organizations have failed to do this. Apparently, few people have the detail-oriented mindset to stock containers with precisely the right inventory, and keep them in perfect order. This very unglamorous job tends to be given a low priority in a field where many people are motivated by grand dreams. Still, it is absolutely essential.

Any coordinator should frequently check that standby equipment is in a ready state. Containers that have been inventoried must be sealed, and any broken seal should be a cause for serious inquiry. Anyone who is found “borrowing” standby equipment should understand that this is a serious infraction, regardless of good intentions to return the item “in just a few minutes.”

Standby equipment that has been stationed in regional locations presents a far bigger challenge, since employee turnover at a cryonics organization may result in records being lost until literally no one knows what is in the containers or even where they are. The coordinator has a serious responsibility to make periodic phone calls to regional groups, visit them, and if necessary bring the containers back to the organization for upgrades and restocking.

Since cryonics is an evolving procedure, there is a constant temptation to include new gadgets in standby kits. The cryonics organization must have a strict policy controlling this, probably requiring that at least three people should concur before changes are made. Any changes should then be duplicated in all standby kits, no matter where they are, and team members must be told about the new items. When a team member opens a container, he should always find exactly what he expects, packed in exactly the same way, ready for us, with absolutely no exceptions. Achieving this can be almost a full-time job in itself.

The one exception to this rule is when an organization maintains a set of standby kits for use in their local area that allows more advanced procedures. Certain pieces of equipment (battery operated mechanical CPR devices, respiratory monitoring devices) may only be affordable for use in local cases. In these situations separate lists for such kits (or vehicle inventory) must be maintained.

### *RONKs*

Individual team members should maintain their own mini-kits of personal items, always packed in a suitcase small enough to be accepted as carry-on baggage by any airline. Since these kits are usually in roll-on bags, they are known as “roll-on overnight kits,” or RONKs. While a team member should have latitude to add specific goodies (such as a video player to help the time

pass during long standby waiting periods), the basic contents are non-negotiable:

- Two changes of clothes, minimum. If uniforms are not issued, attire should be conventional, including white or pale -blue shirts and dark-colored pants such as Dockers. Team members should look professional in a hospital setting.
- Toothbrush, tooth paste, hair brush, nail clippers, soap, other basic grooming accessories.
- Printed materials issued by the cryonics organization, for use when informing medical personnel about cryonics procedures.
- Basic information regarding the organization's location, phone, email, and fax. A map of the route from the airport to the organization.
- Notebook and at least two pens.
- Audio recorder and camera, or reliable handheld device.
- Spare cell phone and charger. Can be a low-cost Wal-Mart phone.
- Name tag (if one has been issued).
- Ear plugs, inflatable pillow, blindfold, and any other accessories that the team member needs to sleep in difficult locations such as hospital waiting areas.
- Any medications or vitamins that the team member needs. Prescription medications must be in properly labeled bottles with the member's name on them.
- Food bars/snack bars.
- Ideally, a cheap laptop computer (such as a netbook) and charger, to be provided by the team member.

- Liquids, gels, or aerosols must be packed separately in a 1-quart ziploc bag for inspection by the Transport Security Administration.

### *Mini-Kits*

A more recent development is to assemble kits that include only the most basic and cost-effective supplies to stabilize a patient. The typical contents of such kits include:

- Drugs to prevent and reverse blood clotting
- Supplies to set up an IV
- A body bag for patient transport and cooling
- Hospital instructions

These kits should not be considered a substitute for a comprehensive standby kit. They are intended as a stopgap measure for caregivers of members who are in a critical condition but do not meet the criteria for a full deployment. The use of such mini-kits allows for basic stabilization procedures when a patient deteriorates faster than expected or when a cryonics organization finds itself confronted with multiple standbys at the same time. Mini-kits can also be sent to areas that do not satisfy the criteria for having a comprehensive set of standby kits but enough infrastructure to do basic standby and stabilization.

## **Logistics**

Once the team has been dispatched for the case, the coordinator's serious work begins. While electronic work aids are useful, a cork bulletin board and wall map are also important, so that anyone who walks into the office can obtain information immediately without asking questions. The wall map, which may be hand-drawn or assembled from pages printed from an online mapping service, should show the patient location, nearby parking spots, mortuary location, car rental/truck location, welding gas supplier location (if

gases will be used), and airport location. The cork board should have contact phone numbers pinned to it, and other information that accumulates during the case.

The coordinator should keep a record of every phone call, including its time, its source, and some key phrases from the conversation. Being able to type while talking is an advantage. The phone log will provide an important cross-check for the timeline of the case after it is completed and the report is being written. Phone logs may also be important if anyone disputes an action or event at a future date. If Skype is used for placing and receiving calls, they can be recorded automatically on the host computer as digital sound files.

If the team has departed by air, the coordinator should reserve at least one car rental and van rental to be available at the destination airport. If the team is traveling via ground vehicle, the coordinator should consider arranging a car rental near the destination, since an extra set of wheels is often very necessary during cases—for instance, if someone needs to return to the hospital to clean up and gather loose items, while the rest of the team has moved on.

Reservations should be made at a hotel or motel as close as possible to the patient. If someone is available with knowledge of the area, the coordinator may obtain the names of some local fast-food places, delis, or mini-marts. Whatever the team is likely to want, the coordinator should be ready to provide, with a goal of allowing team members to focus entirely on their work.

The coordinator should obtain frequent updates of the team's arrival time, and should keep in touch with the patient (if still conscious), family members, hospital personnel, and medical advisors retained by the cryonics organization.

If the team has flown in and will be using a mortuary prep room for blood washout, and if the patient is near death, the coordinator may decide to send one of the team members ahead to the mortuary with the perfusion equipment, to set it up, prime it, de-bubble it, cool the perfusate, and have everything ready when the patient arrives. The loss of this team member from the bedside should be more than offset by the time saving of being able to get to work as soon as the patient reaches the mortuary (assuming there are no



surgical problems). As indicated earlier, it will be helpful if the standby equipment is clearly labeled to distinguish containers that should be at the bedside, and containers that will be needed at the mortuary.

Once the standby begins, the coordinator should make judiciously spaced phone calls to obtain progress reports. This information should then be relayed to medical advisors and management at the cryonics organization.

Assuming that a mortuary has already been found and will be used for blood washout, the coordinator should insure that it is ready to receive the patient. In any instance where extra services are required (for instance, if a mortician has to make an extra trip to the county health department, or has to work unusual hours) the coordinator should be quick to offer additional fees. A few hundred dollars is a small price to pay if it will save an hour or two or help to insure good treatment for the patient.

If independent contractors are being used for the case, the coordinator should know how long each one can stay on-site, and should have replacements lined up, so that personnel can be rotated in and out with minimal disruption.

As the case progresses, the coordinator should check airline schedules, lining up the various possibilities, giving priority to those with the best connections if nonstops are unavailable. This should be done as a contingency plan, even if the team has travelled by ground. The coordinator must always have as many options as possible available.

If the case will use an air ambulance to bring the patient back, the coordinator must make inquiries at two or three different companies, since availability of private jets can fluctuate unpredictably. Note that some air ambulances have a “wide door” configuration. These are the only ones which will accept a wholebody patient in a typical Ziegler steel transport box.

When the patient is ready for transport, the coordinator must verify, as well as he can, that all documents are properly executed. He should then turn to the task of making sure that the operating room is ready and personnel will be available to begin work as soon as the patient arrives.

After the patient reaches the cryonics facility, the coordinator’s job is done, but he should resist the temptation to unwind and get some sleep. First

he should make notes of every fact or observation that seems relevant to the case. Many of these items will be forgotten if he waits until the next day.

A debriefing involving all principal participants in the case should be held via conference call as soon as possible after the case is over. The coordinator should establish a polite and friendly atmosphere in which no one is discouraged from being frank and open. The debriefing should be relentlessly factual, and everyone should understand that its goal is to establish what happened and when, without assigning responsibility or blame. It is not an appropriate time to criticize or hold someone responsible. The debriefing should be recorded, and the recording should be transcribed. A copy should be kept with the patient's records, and another copy should be used for the case report that should be written within the next two to three weeks. Often, the coordinator will be in the best position to write that report.

One persistent problem with debriefings (and the case reports that are based on them) is that there is little systematic follow-up to ensure that the problems that were discussed are dealt with. A good rule of thumb is to determine which problems can be solved by the cryonics organization and assign people to these tasks. During a subsequent post-debriefing meeting staff members (or volunteers) report on the progress that has been made. When quick solutions are possible, these fact that the problem has been addressed should be mentioned in the case report. The importance of this kind of follow-up cannot be underestimated. Debriefing sessions should not just be ritual where people share the strengths and the weaknesses of the case but should be used to ensure that problems that can be resolved by the cryonics organization are not likely to happen in the future.

## **Predicting Cases**

It is estimated that less than a majority of cryonics cases are “good” cases, where this may be defined as the timely deployment of a standby team so that there is little delay between pronouncement of legal death and start of stabilization procedures. One important factor has been inaccurate patient assessment, which we will discuss in Section 7.

A systematic analysis of the membership database can help to reduce the “surprise factor” in cryonics. Members can be grouped by region , high-density areas being a higher risk for cases. We may also try to predict the growth as a function of membership growth. For example, in 2006 Dr. Michael Perry did an analysis of Alcor’s database to predict future caseload and the probability of having simultaneous cases.

Another tool that has been employed is the use of actuarial tables to estimate regional caseload. Although some simplifying assumptions are made (such as assuming no difference between the general population and cryonics members) the information obtained can be used to allocate standby equipment in areas with the highest likelihood of multiple cases. Below is an analysis that was done in March 2009 by Mike Perry and one of the authors (de Wolf) using an actuarial table from the US government Social Security administration (2004). For example, the expected number of cases within a year for California is 2.4 (all results are rounded to tenths).

#### **Expected cryonics cases per year, by state**

State	Females	Males	Total
AK	0.0	0.0	0.0
AL	0.0	0.0	0.0
AR	0.0	0.0	0.0
AZ	0.1	0.8	1.0
CA	0.4	2.1	2.4
CO	0.0	0.1	0.2
CT	0.0	0.0	0.0
DC	0.0	0.0	0.0
DE	0.0	0.0	0.0
FL	0.2	0.4	0.6
GA	0.0	0.1	0.1
HI	0.0	0.0	0.0
IA	0.0	0.1	0.1
ID	0.0	0.0	0.0
IL	0.0	0.1	0.1
IN	0.0	0.1	0.1
KS	0.0	0.0	0.0

LA	0.0	0.0	0.1
MA	0.0	0.2	0.2
MD	0.0	0.0	0.0
ME	0.0	0.0	0.0
MI	0.0	0.0	0.0
MN	0.0	0.1	0.1
MO	0.0	0.0	0.0
MS	0.0	0.0	0.0
NC	0.0	0.1	0.1
ND	0.0	0.0	0.0
NH	0.0	0.0	0.0
NJ	0.0	0.2	0.2
NM	0.0	0.1	0.1
NV	0.2	0.2	0.4
NY	0.1	0.2	0.3
OH	0.0	0.0	0.0
OK	0.0	0.0	0.0
OR	0.0	0.1	0.1
PA	0.0	0.1	0.1
SC	0.0	0.1	0.1
TN	0.0	0.0	0.0
TX	0.1	0.2	0.3
UT	0.0	0.1	0.1
VA	0.0	0.0	0.0
VT	0.0	0.0	0.0
WA	0.0	0.2	0.2
WI	0.0	0.0	0.0

Such an analysis needs to be supplemented by making personal contact with older members periodically and checking the health status of patients with serious conditions. During 2009 Alcor designated a specific room to display these kinds of data and track potential cases. The combination of all these measures will not completely eliminate the surprise factor in cryonics but they go along away towards a more rational approach to readiness.

## **7. Patient Assessment**

When a member of a cryonics organization is diagnosed with a potentially life threatening condition, the outcome of an eventual standby may be greatly improved if we can learn as much as possible about the condition, as early as possible before death is pronounced. This process of information gathering must be carefully distinguished from any active involvement in caregiving for a living person. A cryonics organization would face obvious potential conflicts of interest if it became actively involved in caregiving. While cryonics organization personnel or medical advisors are sometimes asked for and may offer advice regarding decisions relating to terminal care, actual care should be provided by and under the authority of independent medical personnel. Therefore, in this section we will deal only with the passive process of assessment, which may offer three significant benefits:

1. Standby is time-consuming, demanding, and costly. A cryonics organization must determine when it is sensible to deploy a standby team to the bed of the patient. More specifically, a cryonics organization needs to know when it is time to make some specific decisions such as drawing up medications and assembling the portable ice bath.
2. The pre-mortem condition should determine the nature and priorities for initial stabilization procedures. For example, a severely dehydrated patient requires a different protocol from an edematous patient. We may be better able to optimize our intervention after legal death is pronounced if we know as much as possible about the patient before pronouncement.
3. To facilitate future resuscitation, collection of patient data should be as comprehensive as possible.

Good patient assessment is a formidable challenge for a cryonics organization. Unlike the execution of basic stabilization protocols, where skills can be taught through repetition without understanding the underlying medical and technical intricacies, the task of patient assessment requires a detailed understanding of pathophysiology of the terminal and agonal phase.

This challenge is exacerbated by the fact that a lot of what is going on in the final hours of a patient's life has little clinical relevance in contemporary medicine. In fact, as cryonicists, we become most concerned precisely when medicine has "given up" on a patient. The last stages of the dying process receive relatively little attention in medical research because, by definition, the process has become irreversible and the condition has become incurable.

If a patient receives hospice care, we may hope and expect to receive informal bedside guidance from hospice staff based on their long experience with terminal patients. We may also feel more affinity with hospice caregivers than with nurses and physicians, because the processes of hospice and standby are likely to coincide. However, it is important to remember that hospice caregivers may only intervene to ameliorate pain and suffering, while we have an urgent mission to prevent cell death. The hospice and the cryonics organization have very different goals.

Consequently we may find limited guidance when we try to predict the time and circumstances of death, so that we may adjust the timing and protocol of our deployment appropriately. This unsatisfactory situation is unlikely to change until there is more widespread acceptance of the practice of human cryopreservation. Until that time, the best we can do is to document our experience to date and use on-site advice in conjunction with the little information that is available in the mainstream literature to the best of our capabilities.

## **Terminal Diagnosis and the Agonal Phase**

As practiced today, cryonics interventions can only begin after pronouncement of legal death. This means that cryonics patients who do not die as a result of accidents or sudden death usually go through a prolonged terminal phase before cryonics procedures start. This terminal phase is likely to inflict

significant damage on the patient (as described below), and one of the most frustrating aspects of standby work is our inability to do much about this, beyond asking favors and reminding caregivers to honor the patient's wish to be cryopreserved with as little damage as possible.

A terminal illness can be defined as an active disease that cannot be cured or adequately treated with contemporary medical technologies. From a biological perspective this means that the patient is losing his battle to sustain himself as an integrated organism; ultimately his biochemical elements will decompose and return to the biochemical cycle of nature.

As a general rule, during terminal illness the probability of death increases until a point where the patient enters the agonal phase. The agonal phase can be described as a state of general exhaustion, minutes or hours before cessation of pulse and respiration. Its symptoms can be characterized as a state of profound shock in which various parts of the body become hypoxic. From the perspective of patient care, it is important to recognize that injury to the brain may often occur before pronouncement of legal death. As a consequence, the objective of cryonics stabilization procedures to maintain viability of the brain by contemporary criteria is not always possible as a result of pre-mortem pathologies.

## **Terminal Illness and Deployment**

The challenge for a cryonics organization is to deploy a standby team at the right time between the point of determination of terminal illness and pronouncement of legal death. Premature deployment exposes the cryonics organization to financial and logistical challenges, but late deployment can compromise the care of the patient.

It should be noted that deployment challenges are greatly reduced when the patient is moved to a location close to the cryonics facility. In such cases, observation of the patient is possible without making travel arrangements or relying on reports from medical staff or visitors. When there is an unexpected decline of the patient, the cryonics organization should be ready and able to limit the amount of time between circulatory arrest and start of stabilization procedures.

Patient assessment may begin when an applicant first completes the signup process and becomes a member of a cryonics organization. This is obviously of special importance if the new member has already been diagnosed with a terminal condition. The organization must be careful to comply with all provisions of HIPAA (the Health Insurance Portability and Accountability Act, which protects an individual's right to medical privacy), but may certainly explain the potential benefits of sharing data. For example, when a patient is diagnosed with an aggressive cancer, informing the organization of this fact will change the classification of this patient from green to yellow and local standby team members can be notified of the need to review and upgrade their equipment. When a patient becomes terminal or is admitted to a hospice for palliative care, the responsibility of the cryonics organization is changed to actual monitoring of the patient. The task of monitoring should be standardized through the use of data collection sheets which can be interpreted by medical professionals.

## **Psychological Aspects of Terminal Disease and Dying**

A detailed discussion of this topic is beyond the scope of this book, but the cryonics organization can benefit from anticipating and recognizing the most common psychological responses from patients and relatives.

The *Kübler-Ross model* distinguishes five stages of grief for people who are diagnosed with a terminal disease:

- 1. Denial:** The patient does not believe or is unwilling to accept the terminal prognosis.
- 2. Anger:** The patient becomes agitated at life, with family, or medical professionals.
- 3. Bargaining:** The patient is trying to negotiate with fate or a higher power.
- 4. Depression:** The patient recognizes his fate and becomes depressed.
- 5. Acceptance:** The patient comes to terms with his mortality.



These stages do not necessarily occur in all patients in this order, and some critics have questioned the model altogether. In the case of cryonics the model would have to be further refined because people with cryonics arrangements have a different understanding of what a terminal diagnosis means. There has not been a systematic study of how people with cryonics arrangements (and their loved ones) deal with terminal illness, but a good rule of thumb is to expect a combination of the various forms of grief and practical concerns about their cryopreservation and loved ones.

We should not assume that people who have made arrangements for cryopreservation have “dealt with” their fear of death. Cryonics may allow some hope for eventual revival, and the presence of a standby team can be a source of reassurance, but most cryonicists share a very strong attachment to life which may induce equal and opposite fear at the prospect of life being interrupted.

For the same reason, cryonicists may be as likely as anyone else to experience denial or anger when death is imminent. This state of mind may cause the patient to act in ways which are counter-productive or even self-destructive. A person who refuses to accept the reality of his condition may refuse to relocate to an optimal location for a standby, or may become unwilling to cooperate with cryonics personnel. We know of one case where the patient was in the last stages of cancer but was so deeply in denial, it was his wife who insisted that he relocate nearer to his cryonics organization—even though she had no personal interest in cryonics. She simply recognized his lifelong desire to be cryopreserved after legal death, while his state of denial convinced him that he wasn’t going to die and therefore would have no need for cryonics. Such singular cases suggest that in standby situations, the only clear rule is to expect the unexpected.

More commonly, close relatives who are unconvinced by arguments in favor of cryonics may become actively obstructive. To them, a cryonics organization is an intrusion on the final intimate moments between them and the dying person. A cryonics organization needs to strike a delicate balance between respecting such feelings and ensuring that the wishes of the patient are being carried out.

As the patient's condition deteriorates, agitation, heavy sedation, depression, delirium, or coma may make communication impossible. If the patient has an active interest in optimizing stabilization and cryopreservation procedures, these issues need to be addressed when the patient is still clear and alert, preferably in the presence of relatives and medical professionals to encourage their cooperation.

## **The Agonal Phase**

With the exception of people who die of sudden death or extreme trauma, most people will go through an agonal period prior to circulatory arrest. But the fact that the agonal phase is such a widespread phenomenon does not mean that there are a lot of systematic and scientific studies of the agonal phase. This should not be surprising because, per definition, the agonal phase is characterized as being a state for which there is no effective therapeutic treatment.

As in discussions about the signs and symptoms of approaching death, the characterization of the agonal phase is holistic in nature. It is the combination of signs and symptoms that characterize the transition from terminal illness to general exhaustion of the patient.

A distinction has been made between the "pre-active" phase of dying and the "active" phase of dying. In the "pre-active" phase the patient shows increased restlessness, confusion and agitation. He is aware and announces his impending death. There are increased periods of sleep and apnea. In the "active" phase the patient becomes unresponsive to most stimuli and can suffer from severe agitation and hallucinations. Physiological indications that the patient is losing the struggle for survival become evident; cyclic changes in breathing (such as Cheyne-Stokes respiration, which is characterized by progressively deeper and sometimes faster breathing, which then falls off rapidly, resulting in apnea or no breathing at all), the "death rattle," inability to swallow, incontinence, a significant drop in blood pressure, peripheral ischemia, cyanosis and a rigid unchanging position are all indicators of imminent death.

In his 1903 book *Om Doden og de Dose* (the title can be translated as “On Death and the Dead,” but the book is not published in English), Oscar Bloch gives the following description of the agonal state:

“The dying person often lies still. Only a few involuntary movements of the extremities, mostly the hands, reveal that the flaccid muscles have not lost their power altogether. His facial features, anxiously observed by his nearest relatives, reveal no sign of concern, they have changed and he no longer looks himself. The glance of the eye, which indeed expresses the personality is dulled; the eye has lost its lustre; the entire surroundings of the eye which largely are decisive of the expression are flabby, the muscles are no longer capable of contraction and the eyelids are flabby too, contributing further to the dullness of the features. The face looks as if it has become longer, the nose more pointed. The dry lips hang flatly over the jaws. The mouth is half open. The complexion pale, with a yellowish or bluish hue. The brow is studded with droplets of sweat, but the person who wipes his forehead notices that it has become cool. The fumbling hands do not respond to the grasp with which his relative tries once more to communicate with him, from whom he is soon to depart. The breathing is audible, rattling mucus bubbles are heard to run up and down the windpipe, but the dying patient does not notice this and he makes no effort to bring up the mucus. Then the breathing becomes more shallow and weaker, the mucus rattling is heard no more and the patient draws his breath at long intervals. Does he still breathe? Often it is impossible to say when the breathing ceased, at other times the last breath is like a sigh. At the same time the pulse becomes weaker and weaker; it is irregular—and finally one does not know whether or not it can be felt. But yet the heart can be heard to beat, then the heart beat ceases—he dies.”

## **Acidosis**

Under everyday physiological conditions the human body regulates pH within a very tight range. This is known as acid base homeostasis. If pH drops below or rises above the normal range (7.35 – 7.45), endogenous extra-cellular and intracellular buffers and changes in respiration can bring pH back to the

physiological range. During terminal illness and the agonal phase these mechanisms are impaired or overwhelmed by extreme alternations in pH.

Different pathologies during the terminal phase can alter the ability of the body to maintain acid-base homeostasis. Because terminal disease ultimately will give way to the agonal phase, the emphasis in this review will be on agonal acidosis. Unless a patient is suffering from a rare disease that raises the pH prior to death, as a general rule, it should be assumed that the patient will be acidic shortly before and after death.

Blood samples taken from patients hours before death or just after death give pH values that are lower than the physiological range, or incompatible with life (lower than 7.0). Little relationship has been found between pH values and specific terminal diseases. This finding indicates that the general exhaustion that accompanies the agonal phase is characterized by peripheral ischemia-induced acidosis – which is further evidenced by high lactic acid values. These low pH values can be a direct cause of death or an important contributory factor. It has further been observed that the fall in pH is proportional to the duration of the agonal phase.

Acidosis in the cryopatient is detrimental for a number of reasons. A lowered pH increases sodium concentrations in the cell by activation of the Na<sup>+</sup>/H<sup>+</sup> exchanger, releases iron and increases free radical formation through the Fenton reaction, suppresses neurotrophin synthesis, and decreases the ability to lower intracellular calcium accumulation. Acidosis may also impair cerebral vascular autoregulation. An acidic environment may further reduce or eliminate the effectiveness of drugs that are pH sensitive such as heparin and epinephrine. A low pH can also accelerate decomposition as hydrolytic enzymes are released from damaged lysosomes.

As a general rule, acidosis should be assumed after pronouncement of legal death. To counter acidosis two interventions are employed: prompt restoration of ventilation, and administration of the buffering agent THAM (Tromethamine). The use of sodium bicarbonate is discouraged because it can cause a paradoxical rise in intracellular pH as a result of diffusion of the carbon dioxide constituent into the cells. Blood gases and fluid samples can be taken during cardiopulmonary support, blood substitution, and cryoprotective perfusion.

## **Microcirculatory Disturbances**

Before the patient's compensatory mechanisms are overwhelmed and inevitable decline sets in, the body tries to protect the essential organs by redirecting blood flow to the core. As a consequence, peripheral circulation is compromised. In the critically ill patient such a response is not followed by a return to healthy homeostasis, but by progressive disintegration.

If cardiac output falls, blood flow can bypass peripheral capillaries, which increases blood return to the heart but can produce regional hypoxia and endothelial injury. Endothelial hypoxia and inflammatory responses enlarge pores between vessels, which leads to increased permeability and edema. Microcirculatory stasis inhibits flow of red blood cells and other blood elements. The aggregation of formed elements and red blood cell hypoxia aggravate stasis of blood flow. As the deterioration of the patient increases, more and more parts of the body are affected and the central circulation will become progressively involved as well.

Also reduced is intestinal blood flow. Low splanchnic blood flow can lead to increased mucosal permeability, endotoxemia and multiple organ failure. Low gastric mucosal pH has been found to have a high specificity for predicting patient survival in critically ill patients. As such, the gastrointestinal system has been called 'the motor of multiorgan failure.' Cryonics patients experience many of the conditions associated with gastrointestinal dysfunction (e.g. , trauma, shock, hypovolemia) and are exposed to a number of cryonics procedures that can worsen these complications (e.g. , prolonged low flow CPR, vasoconstriction, hypothermia, CPB). Gastrointestinal complications such as hyperpermeability and abdominal swelling are not limited to stabilization and transport, but can also have profound effects on the ability to cryoprotect whole body patients. Gastrointestinal ischemia and its effects during the terminal and agonal phase should therefore be closely monitored because abnormalities observed prior to pronouncement of legal death are a good indicator of what can be expected during CPS, blood washout, and cryoprotective perfusion. When severe abdominal edema is observed prior to circulatory arrest a determination needs to be made regarding how this

condition can affect other parts of cryonics procedures and how to deal with them.

## **The No-Reflow Phenomenon**

One of the most harmful events during terminal illness and the agonal phase is the development of perfusion abnormalities. Perfusion impairment of the (micro) circulation, and that of the brain in particular, has a number of adverse consequences. Pre-mortem, it can lead to energy depletion of neurons and initiate the beginning of the biochemical cascade ending in decomposition. Post-mortem, it can interfere with effective cardiopulmonary support, circulation of neuroprotective medications, and the efficiency of cooling.

Most research into the no-reflow phenomenon since the 1960s has studied the effects of various durations and forms of ischemia on flow. It is now increasingly recognized that perfusion impairment manifests itself in the critically ill patient as well. The causes of such disturbances in normal flow remain a matter of debate, but contributing factors include local and systemic inflammation, metabolic exhaustion and rheological abnormalities.

In the terminal patient a distinction needs to be made between alterations in blood flow as a defensive response of the organism to protect the brain and the vital organs and alterations in blood flow that reflect a general failure of the patient to maintain homeostasis. This difference becomes most clear during the agonal phase when the brain is no longer exempted from pathological events and metabolic and microcirculatory failure produce pronounced effects on the awareness and consciousness of the patient.

Aside from conveying this issue to the attention of medical caregivers and those that can make medical decisions for the patient, cryonics organizations can do little to prevent perfusion impairment during the agonal phase. The recognition that no-reflow is not just a potential risk of delayed intervention after circulatory arrest but should be assumed to exist in most patients has important consequences for standby and stabilization protocols. Unless otherwise indicated, aggressive protocols to reverse no-reflow such as hypertension, administration of (hypertonic) volume expanders, and rapid

induction of hypothermia should be given great priority. Minimizing the time between pronouncement of legal death and blood washout is also beneficial.

## **Dehydration**

Most cryonics patients who present for stabilization are dehydrated. In rare cases this can be the consequence of the patient refusing food and water. In other cases the inability to process fluids without assistance can contribute to fluid imbalances. An important contributing factor is the decision to stop any kind of medical treatment, including palliative care, in the final phase of dying.

Severe dehydration (>9%) manifests itself through various symptoms including reduced blood pressure, alterations in pulse, increased heart rate (bradycardia in very severe cases), dry mucous membranes, sunken eyes, cool and mottled extremities, lethargic or comatose mental status, decreased urine output and severe thirst.

Most symptoms of dehydration (or the agonal phase in general) constitute no object for reversal during cryonics stabilization protocol. The fundamental reason why cryonics should be aware of dehydration is because rehydration with suitable volume expanders can increase blood pressure during stabilization. Extreme dehydration can also be a concern because a severe lack of water can reduce metabolism of neuroprotective drugs.

In the medical literature various forms of dehydration are distinguished. One distinction that is important for cryonics patient assessment is that among loss of water with equal electrolytes (isotonic dehydration), loss of water that exceeds loss of electrolytes (hypertonic dehydration), and loss of water that is less than the loss of electrolytes (hypotonic dehydration). When hypotonicity is expected, it is important not to aggravate this condition by the administration of isotonic or, worse, hypotonic solutions. As a general rule, hypertonic solutions are recommended for cryonics patients because these agents can recruit water from edematous tissue, including the brain.

## **Neurological Damage**

Securing viability of the brain by contemporary criteria is the most important objective of cryonics standby and stabilization. Recognition of the mechanisms through which pathological events in the central nervous system can defeat this objective is of great importance. As a general rule, the risk for increased brain damage is higher during slow dying. For example, when the ventilator is removed from the patient who is not able to breathe on his own, the time between this action and circulatory arrest can be short. Conversely, when a patient is going through a prolonged terminal and agonal phase, (regional) injury to the brain can occur while the body itself is still fighting for survival.

The human brain has little storage of excess energy. As a result, hypoxia causes the brain to deplete its oxygen reserves within 30 seconds. The energy depletion that follows cerebral hypoxia during the dying phase has a number of distinct effects:

1. Excitation or depression of certain processes in the brain.
2. Alteration in the maintenance of structural integrity of tissues and cells.
3. Alteration of neuromediator synthesis and release.

The depletion of oxygen leads to a switch from aerobic to anaerobic energy production. As a consequence, there is an increase in the metabolic end-products of glycolysis such as lactic acid, which decreases pH in the brain. After five minutes, no useful energy sources remain in the brain, which can explain why the limit for conventional resuscitation with no neurological deficits is put at five minutes as well. Because the dying phase leads to progressively worse hypotension and hypoxia, the metabolic state of the brain after the agonal phase is worse than if there would have been sudden cardiac arrest.

Light microscopic changes have been observed in brain cells after five minutes of ischemia. Prolonged hypotension, as can occur in the agonal patient, can lead to the appearance of “ghost cells” and disappearance of nerve



cells. Such observations provide evidence that structural changes, including cell death, can occur prior to clinical death. Another manifestation of hypoxia (or hypotension) is the progressive development of cerebral edema. The resulting narrowing of vessels and decrease of the intercellular space can, in turn, aggravate energy delivery to tissues. Of particular importance for cryonics stabilization procedures is the development of no-reflow (see above), which can prevent complete restoration of perfusion to parts of the brain during cardiopulmonary support. There is no consensus whether no-reflow can occur as a result of prolonged hypotension (as opposed to complete cessation of blood flow) but an extended dying phase can set the stage for cerebral perfusion impairment after circulatory arrest.

The central nervous system does not shut down at once. Throughout the terminal and agonal phase, alternations in the brain progress from minor changes in awareness and perception to deep coma. As a general rule, more recent and complex functions of the brain disappear earlier than the most basic functions of the brain. The uneven brain response to hypoxia may reflect different energy requirements, biochemical and structural differences, and/or the activation of protective mechanisms to preserve the “core” functions of the brain. The CA1 region of the hippocampus is uniquely vulnerable to ischemia. This presents a problem for contemporary cryonics since the objective of human cryopreservation is to preserve the identity-relevant information in the brain.

## **The “Death Rattle”**

One specific symptom that is often encountered in the dying is the so called “death rattle.” This is a “choking” sound which occurs when air moves through mucus that has accumulated in the throat of a dying person who can no longer remove the secretions by swallowing.

In the technical literature a distinction has been made between the “real” death rattle that is a consequence of salivary and bronchial secretions, and a death rattle that is produced by pulmonary pathologies.

The death rattle is often associated with removal of mechanical ventilation in the patient. It is more commonly found in patients dying from brain trauma and brain tumors.

In the dying patient the death rattle is perceived as a good indicator of death, with studies predicting a median time of 16 hours until dead. In the specific case of removal of mechanical ventilation (or any other withdrawals of life support) these times can be much shorter. If the symptoms of the death rattle present during the agonal phase treatment is often confined to administration of drugs that reduce excretions to comfort the family. As a general rule, symptoms of the death rattle indicate that a cryonics standby team should be prepared for the initiation of stabilization procedures. If no such team is deployed yet, development of the death rattle, in combination with other symptoms, should be considered a reason to deploy.

## **Predicting Death**

We would derive obvious benefits if we were able to predict a patient's time of death with reasonable accuracy. The time between circulatory arrest and start of cryonics procedures would be minimized. Time-consuming and costly standby deployments would be avoided, and team members would be less prone to sleep deprivation and fatigue. While it is true that a patient's prognosis tends to become more definite with the passage of time, unfortunately the prediction of death remains as much an art as a science. We have known hospice personnel who believe they have an instinctual predictive ability, and we have known doctors who make predictions based on data. In both groups, predictions have been wrong by as much as a week. In some instances, a patient recovers and returns to everyday life.

Still, the indicators listed below may provide valuable guidance, so long as they are used in conjunction with advice from experienced caregivers. As a general rule, none of these signs can be relied upon for precisely predicting the time of death and need to be interpreted in context. Establishing a trend is often more meaningful than relying on abnormally low or high values. Generally speaking, the probability of dying increases when an increased number of these signs are observed. It should be remembered that there is

often no comparison to discussing the terminal course of the patient with a practiced medical caregiver, in particular, those with extensive experience in palliative care. Hospice personnel can often predict death within about five hours of the event.

### *Signs of Impending Death*

#### **Blood gases and chemistry**

- Acidosis
- Elevated lactic acid content
- High concentration of ions in the blood
- Reduced bicarbonate levels

#### **Physiological**

- Fever
- Hypotension
- Peripheral venous stasis
- Involuntary evacuation of urine and feces
- Irregular and weak pulse

#### **Respiratory**

- Death rattle
- Irregular breathing (Cheyne-Stokes breathing)
- Low end tidal CO values

#### **Visual and tactile observations:**

- Cyanosis
- Decrease in skin turgor
- Dilated pupils
- Dry tongue
- Extreme weight loss
- Edema of the lower extremities
- Jaundice
- No corneal reflexes

Pale skin color

Sweating

### **Neurological**

Delirium

Dullness

Unconsciousness

We must emphasize that the absence of one or more of these indicators should not be used as justification for delaying deployment of team members. If many of these signs are observed, and follow a deteriorating trend, a standby team should be present at all times. Observing these indicators can be helpful for making practical and logistical decisions such as the changing of team members, drawing up medications and deploying equipment and other decisions that need to be made to provide prompt stabilization.

Many of these signs of impending death can be observed without invasive or complicated medical procedures. A pulse oximeter, for instance, merely makes external contact with the skin at the tip of a finger, while providing very valuable data. At the same time, the use of any medical device may constitute treatment, especially in the eyes of hospital staff, and cryonics personnel must be extremely careful to avoid crossing the strict line between passive observation and active involvement. Ideally, personnel should establish their right to share data obtained by caregivers on a cooperative basis, long before a patient becomes agonal; but in a less-than-ideal situation, diplomatic negotiation will be necessary.

At the end of this section we include four “pre-mortem” data collection sheets. Also you will find an information sheet with normal values for blood gases and chemistry, and the methodology to calculate the Glasgow Coma Score.

### **Notable Patient Conditions**

In ideal circumstances the cryonics organization’s standby protocol would be tailored to the individual pathophysiology of the patient prior to circulatory

arrest. In the real world the best a cryonics organization can do is to strike a balance between providing basic stabilization procedures that are effective for all (such as rapid cooling) and recognizing special conditions of the patient that mandate a change in procedures. It is impossible to provide a comprehensive list of items that the cryonics organization needs to look for, but what follows is a basic discussion of such conditions. In some cases, information about conditions can be solicited when the member is still healthy. A cryonics organization should encourage their members to voluntarily submit such information to minimize the need for last-minute improvisation.

### *Logistical and Legal*

Logistical and legal considerations fall outside of the scope of this chapter but it should be emphasized that the benefits of doing a thorough assessment of the condition of the patient are highly dependent on the location of the patient, securing cooperation from hospital or hospice staff and ensuring the legal and medico-legal elements are in place for a prompt stabilization of the patient.

### *Anatomical*

The cryonics organization needs to be aware if a patient is extraordinary tall or heavy. In such circumstances additional logistical challenges should be expected. In rare circumstances custom-designed equipment needs to be built. Another scenario where conventional equipment (such as the portable ice bath) may be inadequate is when the patient suffers from a bone disease that does not allow the legs to be folded to fit the width of the ice bath. Extreme obesity or certain bone diseases may present challenges for mechanical cardiopulmonary support.

### *Cardio-Respiratory*

There are so many physiological and pathological conditions of a patient that could induce the cryonics organizations to alter protocol that we can only list a number of them that impact basic stabilization procedures.

One of the biggest obstacles for vigorous cardiopulmonary support are fragile or broken chest bones. Such a condition can be due to diseases like

cancer or prior resuscitation efforts. If there are concerns about the wisdom of using aggressive mechanical chest compression due to a fragile chest, the Chief Medical Advisor should be consulted.

Many patients will have pulmonary edema at the time of arrest, or will develop fulminating edema during closed chest compressions. To counter the effects of large amounts of fluids in the lungs and alveolar flooding, conventional ventilation cannot be relied upon and needs to be replaced with continuous high pressure ventilation and PEEP.

### *Hemodynamics and Blood Abnormalities*

Depending on the terminal course of the patient, the patient can be either severely dehydrated or very edematous. To complicate matters, edema and hypovolemia can co-exist in the terminal patient. Correctly assessing the fluid balance of the patient is important to choose the right course of action: either administration of large volume fluids to restore blood and cerebral pressure, or limiting large volume fluids to prevent increased edema in the patient.

Development of hyperviscosity, hyper-coagulation, and platelet aggregation during the terminal phase can present formidable obstacles to restoring blood flow as it will result in areas of the circulation being excluded from perfusion. In general, such a state should be expected in cryonics patients but if this condition exists to a more extreme degree, additional pharmacological strategies should be considered. Conversely, if the patient has recently experienced brain hemorrhage, administration of fibrinolytics, anti-coagulants and anti-platelet agents should be approached with caution.

A special case presents itself when the patient is suffering from cold agglutinin disease. In such cases, red blood cells will have a tendency to aggregate during induction of hypothermia. Because rapid induction of hypothermia is the most effective general neuroprotective intervention in cryonics the most effective response would be to minimize the time between pronouncement of legal death and blood washout.

As a general rule, energy depletion by cardiac arrest will initiate a cascade of events that produce microcirculatory pathologies and regional obstructions to cerebral blood flow. These events should be countered with a protocol of hypertension, hemodilution, and anti-coagulation. It cannot be

emphasized enough that the large volume medications are not intended to be administered as an afterthought but are meant to be used at the start of stabilization procedures concurrent with the neuroprotective agents.

### *Neurological*

The fundamental objective of stabilization is to prevent (further) deterioration of the brain. If the patient presents with cerebral edema or elevated intracranial pressure (for example, as a consequence of brain cancer) the perfusion pressures generated by cardiopulmonary support may not be adequate and oxygenation and distribution of medications will be compromised. In such cases, the high volume medications should be given priority to restore pressure and hemodilute the blood. In particular, the anti-edema agent mannitol should be administered promptly to reduce swelling of the brain. Further reduction of cerebral edema can be achieved by substitution of the blood with the hyper-osmotic MHP-2 solution.

In patients who have experienced multiple episodes of stroke or suffer from prolonged neurodegenerative diseases the ratio of cerebral spinal fluid (CSF) to brain tissue may be elevated. As a consequence, equilibration of the brain with the vitrification solution will require longer perfusion times. A more radical intervention would be to evacuate the CSF from the brain to eliminate vast amounts of fluid with low glass forming tendencies.

### *Allergies*

The sheer volume of medications used in Alcor's stabilization protocol excludes a detailed review of all the indications and contra-indications for their use, and the reader is referred to the documentation that is supplied with the drugs. Of notable interest is to determine whether there is a risk of anaphylactic shock, in which case the administration of large volume medications like Dextran 40 and hydroxyethyl starch (HES) should be reconsidered and replacements should be sought.

### *Infections and Transmittable Diseases*

In some cases, the patient's condition can present a danger for the team members. As a general rule, special precautions should always be taken. In

cases such as AIDS or any highly dangerous diseases that can be transferred by blood or air, no stabilization procedures should be initiated without extensive consultation of Alcor's medical staff and advisors and the patient's caregivers.

## **A Special Case: Self-Denial of Food and Drink**

One course of events that leads inevitably to circulatory arrest within a matter of weeks is the conscious decision to refuse all food and drink. Such a decision to hasten death should be distinguished from terminal states characterized by a decreasing appetite, such as seen in cancer.

Self-denial of food and drink is often the last resort for people who want to end their life in a dignified manner when physician-assisted dying is not available in their country or state, or when they do not meet the criteria for these procedures. Self-denial of food and drink is of special interest to cryonicists because it is the only form of self-directed termination of life that normally eliminates the risk of an autopsy. It is usually not employed to hasten death but as means to induce circulatory arrest to prevent a brain-threatening disease running to completion. Because self-denial of food and drink requires a resilient and committed patient to continue the decision made, there cannot be any doubt about the voluntary nature of this act.

There has been at least one well-documented case of self-denial of food and drink in cryonics and there is good reason to believe that this strategy to prevent progressive destruction of the identity of the person may be chosen by individuals in the future. As such, cryonics providers need basic knowledge about what this decision entails in terms of medical care and deployment.

If the decision to deny food and drink is respected by medical caregivers, the unfolding course of events is not necessarily harder on a patient than that observed in other irreversible terminal states. Although a doctor can refuse to participate in palliative care for a patient who has chosen this course of action, such a doctor is expected to release himself from the patient's care to make place for a physician without such objections.

The course of events for a person who has chosen to refuse food and drink depends on a number of things such as the medical condition of the



patient and the specific implementation of the decision. If a patient categorically denies any food and drink the time to circulatory arrest is shorter than if the patient gradually reduces his intake of food and fluids. Most patients who follow such a regime are expected to die between 7 and 15 days. The time course for patients who follow a more gradual approach is less predictable and can last for more than a month.

The ensuing course of events does not necessarily need to involve a lot of suffering if adequate attention to mouth care, pain management and prevention of delirium is given. In his publication 'A Hastened Death by Self-Denial of Food and Drink,' Boudewijn Chabot outlines a number of important points:

- The patient should express his wishes in his legal paperwork and, preferably, also in a signed and dated letter for his doctor.
- The bowel should be cleared prior to the start of fasting to avoid accumulation of food remnants in the large intestine which can facilitate a confused and anxious state.
- Adequate mouth care should be available to prevent drying out of the mouth and to relieve extreme thirst.
- As in conventional palliative care, medications should be provided throughout the course of events to relief pain, discomfort and anxiety.

Because hastening death by self-denial of food and drink is not a routine elective medical procedure, pathophysiological data about it are limited and confined to information gathered from medical caregivers, relatives, and data from related phenomena such as abstention for religious or political reasons.

When the intake of sugars or other carbohydrates ceases, the body will switch to other sources of nutrients such as fat and protein reserves. Increasingly, urea can no longer be excreted by the kidneys because of a lack of fluids. The generation of endorphins and the increase of urea levels in the blood can contribute to a pleasant state of drowsiness. As the hydration of the patient keeps declining, the concentration of ions in the blood keeps

increasing, eventually leading to cardiac arrest. Because the amount of fluid that is sufficient to moisten and hydrate the mucous membranes in the mouth falls short of the hydration that is required to sustain life, the adversity of effects of refusing fluid on the mouth, and the extreme thirst this produces, can be alleviated without reversing the course of events that the patient has chosen.

Unless the cryonics organization believes that the patient's medical condition would trigger a sudden acceleration of events leading to early cardiac arrest, the expected time-course after such a decision is announced should allow for a gradual deployment of standby equipment and a protocol of stepping up monitoring efforts. Because a decision to refuse all food and drink will often be made to avert destruction of the brain and facilitate a better cryopreservation, it is of great importance that officials of the cryonics organization abstain from involvement in the execution of this decision and care during the terminal phase.

## **Data Collection**

Patient data during the terminal and agonal phase are usually collected by medical staff as a routine part of patient care. If there is good cooperation with the hospital and hospice staff, the most important job for the cryonics organization is to interpret the data and make sensible deployment, standby and stabilization decisions. After completion of the case, the cryonics organization should request all medical data that were collected during the terminal care to produce a detailed case report.

A meta-analysis of all available pre-mortem data will allow the cryonics organization to have better quantitative and qualitative understanding of its patients, which can contribute to better readiness, standby and stabilization policies. In particular, cryonics organizations have strong interest in knowing basic information about cryonics patients as a group such as the distribution of causes of death, location of death (hospital / hospice / out-of-hospital location) and duration of standby.

PATIENT TREND SHEET A

Location: \_\_\_\_\_

Date	Military Time	Resp	Pulse	O <sub>2</sub> Sat	Cap Refill	Blood Pressure	Temp	Skin	L Pupils	R Pupils	GCS	Init
		Rate: /min <input type="checkbox"/> Regular <input type="checkbox"/> Shallow <input type="checkbox"/> Labored	Rate: bpm <input type="checkbox"/> Regular <input type="checkbox"/> Irregular		Hands: _____ Feet: _____ (seconds)	Sys: _____ Dias: _____ <input type="checkbox"/> Central <input type="checkbox"/> Peripheral	° <input type="checkbox"/> C <input type="checkbox"/> F	<input type="checkbox"/> Unremarkable <input type="checkbox"/> Cool <input type="checkbox"/> Warm <input type="checkbox"/> Moist <input type="checkbox"/> Dry <input type="checkbox"/> Pale <input type="checkbox"/> Cyanotic <input type="checkbox"/> Flushed <input type="checkbox"/> Jaundiced	Size (mm) <input type="checkbox"/> Round <input type="checkbox"/> Reactive <input type="checkbox"/> Sluggish <input type="checkbox"/> Fixed	Size (mm) <input type="checkbox"/> Round <input type="checkbox"/> Reactive <input type="checkbox"/> Sluggish <input type="checkbox"/> Fixed		
		Rate: /min <input type="checkbox"/> Regular <input type="checkbox"/> Shallow <input type="checkbox"/> Labored	Rate: bpm <input type="checkbox"/> Regular <input type="checkbox"/> Irregular		Hands: _____ Feet: _____ (seconds)	Sys: _____ Dias: _____ <input type="checkbox"/> Central <input type="checkbox"/> Peripheral	° <input type="checkbox"/> C <input type="checkbox"/> F	<input type="checkbox"/> Unremarkable <input type="checkbox"/> Cool <input type="checkbox"/> Warm <input type="checkbox"/> Moist <input type="checkbox"/> Dry <input type="checkbox"/> Pale <input type="checkbox"/> Cyanotic <input type="checkbox"/> Flushed <input type="checkbox"/> Jaundiced	Size (mm) <input type="checkbox"/> Round <input type="checkbox"/> Reactive <input type="checkbox"/> Sluggish <input type="checkbox"/> Fixed	Size (mm) <input type="checkbox"/> Round <input type="checkbox"/> Reactive <input type="checkbox"/> Sluggish <input type="checkbox"/> Fixed		
		Rate: /min <input type="checkbox"/> Regular <input type="checkbox"/> Shallow <input type="checkbox"/> Labored	Rate: bpm <input type="checkbox"/> Regular <input type="checkbox"/> Irregular		Hands: _____ Feet: _____ (seconds)	Sys: _____ Dias: _____ <input type="checkbox"/> Central <input type="checkbox"/> Peripheral	° <input type="checkbox"/> C <input type="checkbox"/> F	<input type="checkbox"/> Unremarkable <input type="checkbox"/> Cool <input type="checkbox"/> Warm <input type="checkbox"/> Moist <input type="checkbox"/> Dry <input type="checkbox"/> Pale <input type="checkbox"/> Cyanotic <input type="checkbox"/> Flushed <input type="checkbox"/> Jaundiced	Size (mm) <input type="checkbox"/> Round <input type="checkbox"/> Reactive <input type="checkbox"/> Sluggish <input type="checkbox"/> Fixed	Size (mm) <input type="checkbox"/> Round <input type="checkbox"/> Reactive <input type="checkbox"/> Sluggish <input type="checkbox"/> Fixed		
		Rate: /min <input type="checkbox"/> Regular <input type="checkbox"/> Shallow <input type="checkbox"/> Labored	Rate: bpm <input type="checkbox"/> Regular <input type="checkbox"/> Irregular		Hands: _____ Feet: _____ (seconds)	Sys: _____ Dias: _____ <input type="checkbox"/> Central <input type="checkbox"/> Peripheral	° <input type="checkbox"/> C <input type="checkbox"/> F	<input type="checkbox"/> Unremarkable <input type="checkbox"/> Cool <input type="checkbox"/> Warm <input type="checkbox"/> Moist <input type="checkbox"/> Dry <input type="checkbox"/> Pale <input type="checkbox"/> Cyanotic <input type="checkbox"/> Flushed <input type="checkbox"/> Jaundiced	Size (mm) <input type="checkbox"/> Round <input type="checkbox"/> Reactive <input type="checkbox"/> Sluggish <input type="checkbox"/> Fixed	Size (mm) <input type="checkbox"/> Round <input type="checkbox"/> Reactive <input type="checkbox"/> Sluggish <input type="checkbox"/> Fixed		
		Rate: /min <input type="checkbox"/> Regular <input type="checkbox"/> Shallow <input type="checkbox"/> Labored	Rate: bpm <input type="checkbox"/> Regular <input type="checkbox"/> Irregular		Hands: _____ Feet: _____ (seconds)	Sys: _____ Dias: _____ <input type="checkbox"/> Central <input type="checkbox"/> Peripheral	° <input type="checkbox"/> C <input type="checkbox"/> F	<input type="checkbox"/> Unremarkable <input type="checkbox"/> Cool <input type="checkbox"/> Warm <input type="checkbox"/> Moist <input type="checkbox"/> Dry <input type="checkbox"/> Pale <input type="checkbox"/> Cyanotic <input type="checkbox"/> Flushed <input type="checkbox"/> Jaundiced	Size (mm) <input type="checkbox"/> Round <input type="checkbox"/> Reactive <input type="checkbox"/> Sluggish <input type="checkbox"/> Fixed	Size (mm) <input type="checkbox"/> Round <input type="checkbox"/> Reactive <input type="checkbox"/> Sluggish <input type="checkbox"/> Fixed		
		Rate: /min <input type="checkbox"/> Regular <input type="checkbox"/> Shallow <input type="checkbox"/> Labored	Rate: bpm <input type="checkbox"/> Regular <input type="checkbox"/> Irregular		Hands: _____ Feet: _____ (seconds)	Sys: _____ Dias: _____ <input type="checkbox"/> Central <input type="checkbox"/> Peripheral	° <input type="checkbox"/> C <input type="checkbox"/> F	<input type="checkbox"/> Unremarkable <input type="checkbox"/> Cool <input type="checkbox"/> Warm <input type="checkbox"/> Moist <input type="checkbox"/> Dry <input type="checkbox"/> Pale <input type="checkbox"/> Cyanotic <input type="checkbox"/> Flushed <input type="checkbox"/> Jaundiced	Size (mm) <input type="checkbox"/> Round <input type="checkbox"/> Reactive <input type="checkbox"/> Sluggish <input type="checkbox"/> Fixed	Size (mm) <input type="checkbox"/> Round <input type="checkbox"/> Reactive <input type="checkbox"/> Sluggish <input type="checkbox"/> Fixed		







APPENDIX 1

Glasgow Coma Score		
Eye Opening (E)	Verbal Response (V)	Motor Response (M)
4=Spontaneous 3=To voice 2=To pain 1=None	5=Normal conversation 4=Disoriented conversation 3=Words, but not coherent 2=No words.....only sounds 1=None	6=Normal 5=Localizes to pain 4=Withdraws to pain 3=Decorticate posture 2=Decerebrate 1=None
(Lowest possible score is 3 not 0.)		
Total = E+V+M		

(As an example, a Glasgow Coma Score would be recorded as follows: GCS 10 = E3 V3 M4 at 08:42.)

Scores are classified as:  
 GCS ≤ 8 = Severe;  
 GCS 9 -12 = Moderate  
 GCS ≥ 13 = Mild

Normal Blood Gas and Chemistry Values:

	Arterial	Venous
pH	7.35 – 7.45	7.31 – 7.41
pO <sub>2</sub>	75 – 100 mmHg	30 – 40 mmHg
pCO <sub>2</sub>	35 – 45 mmHg	41 – 51 mmHg
TCO <sub>2</sub>	24 – 30	25 – 33
HCO <sub>3</sub> <sup>-</sup>	22 – 26 mEq/L	22 – 29 mEq/L
O <sub>2</sub> Sat	95 – 100% (sea level; room air)	60 – 85%
BE	-2 to +2 mmol/L	0 to 4mmol/L
Lactate	4.5 - 14.4 mg/dL	4.5 – 19.8 mg/dL
NA	135 - 145 mEq/L	
K	3.5 – 5.0 mEq/L	
Cl	95 – 105 mEq/L	
Ca	2.2 – 2.5 mEq/L	
Mg	1.6 – 2.6 mEq/L	
PO <sub>4</sub>	2.5 – 4.5 mg/dL	
BUN	5 – 25 mg/dL	
Creatinine	0.5 – 1.5 mg/dL	
Hgb	Male: 13 – 18 g/dL; Female: 12 – 16 g/dL	
Hct	Male: 42 – 52 g/dL; Female: 37 – 47 g/dL	
Anion Gap	10 – 12 mEq/L	
Osmolality	280 – 300 mOsm/kg	
Albumin	3.5 – 5 g/dL	
Total Protein	6.0 – 8.0 g/dL	

## **8. Health Issues and Communicable Diseases**

While cryonics has aimed for the acceptance and participation of medical professionals in its procedures, to some degree the field has always depended on volunteers who lack such credentials and who have acquired most of their knowledge and skills through self-education and practice. As a consequence, many of these volunteers may not have formal training to identify potential health hazards during cryonics cases, nor possess the knowledge to prevent and treat them. This short section identifies the areas in cryonics operations where precautions should be taken to deal with health hazards such as infection risk or blood-borne diseases.

### **Perfusate preparation**

The history of cryonics can be characterized as sustained progress towards lower toxicity cryoprotectants, from the early days of DMSO and glycerol to today's peer-reviewed vitrification solutions. It would be a mistake, however, to assume that this progress implies correspondingly decreased health hazards in perfusate preparation. For example, the combination of DMSO and formamide is a core principle of reducing overall toxicity in today's vitrification solutions. However, a chemical such as formamide on its own presents more serious health issues to staff members than a chemical such as glycerol. Consequently, perfusate preparation should be performed under conditions that protect staff members from health hazards such as respiratory problems and teratogenic effects. In practice, this means that perfusates (cryoprotectants in particular) should be prepared using personal protective equipment and in conjunction with a fume hood or other ventilation to prevent exposure to fumes.





*Figure 8-1. Fume Hood for protection against toxic chemicals and gases.*

## **Emotional Stress**

Like pre-hospital emergency medicine or military medicine, cryonics procedures can be emotionally stressful. In addition to the elements that

contribute to emotional stress in pre-hospital care, cryonics has a number of distinct characteristics that can exacerbate stress:

**Hostility from family, third parties, and medical professionals.**

Unlike conventional emergency medicine, cryonics team members should be prepared for skeptical, hostile, and even uncooperative responses. These can range from attempts by family members to interfere with deployment and procedures, to legal threats from hospital administrators. As a general rule, the best response is to remain polite and to emphasize that you are there to *honor the wishes of the patient*, who has voluntarily chosen to make cryonics arrangements. In case of doubt or legal threats, the best course of action is to contact your organization for further instructions. If you think you are not able to deal with this kind of stress, remove yourself from the team if you can do so without compromising response capabilities.

**Fatigue.**

Unlike conventional pre-hospital care, in which EMS teams rotate to prevent long hours and fatigue, standby deployments are often characterized by prolonged periods of wakefulness and anxiety. If such fatigue combines with additional stress associated with hostile family members or third parties, the result can be volatile. It is of great importance that a cryonics organization deploys enough people to allow adequate resting time without risking that the patient will go into cardiac arrest without enough team members present.

**Unexpected technical and logistical problems.**

A typical cryonics case is more akin to an experimental form of military medicine than an in-hospital procedure. Despite the fact that more than 200 cryonics cases have been performed to date, each case is prone to throw some unexpected technical and logistical problems at team members. These problems can further attribute to stress levels. It is not realistic to anticipate all potential problems, but the number of such problems can be substantially reduced if those participating in a case have studied case reports in detail and are well versed and trained in the equipment that they are using.

- Common warning signs of stress include:
- Difficulty sleeping.

- Irritability.
- Sadness.
- Guilt.
- Indecisiveness.
- Loss of appetite.
- Loss of interest in work.
- Physical symptoms.
- Lack of focus or concentration

It cannot be emphasized enough that ensuring the presence of sufficient team members and allowing a person to balance personal life and cryonics case work can prevent a lot of stress related problems.

## **Scene Safety**

This concept is emphasized in conventional emergency medicine because pre-hospital professionals typically operate in an environment where a serious accident has occurred and substantial risk remains a possibility. Many of these scenarios are not relevant to cryonics (for example, it is not likely that a cryonics team will be stabilizing a patient immediately after a homicide or car accident) but that does not mean that this topic can be ignored altogether.

Cryonics team members do often need to perform labor-intensive and equipment-intensive standby procedures in environments such as hospitals, single-family homes, and apartments. From the moment of pronouncement of legal death to arrival at the cryonics facility, there are numerous opportunities for personnel to be injured. In particular, the lifting and moving of a patient, especially in a fully loaded ice bath, can be hazardous for volunteers who have not been appropriately trained.

Cryonics procedures are often performed during transport to the vehicle and while driving. A cryonics organization can get a good understanding of the kinds of health risks that are typically encountered in these situations by

conducting a dry run and documenting the risks. Such documents in turn should be used to conduct relevant training sessions under the leadership of certified medical professionals such as paramedics, to teach team members the proper skills and treatment options.

## **Communicable Diseases**

Various modes of transmission exist for infectious and contagious diseases.

**Contact transmission.** This mode can be divided into direct personal contact with the carrier of a disease and indirect personal contact through an intermediate object, such as a doorknob or infected material.

**Droplet transmission.** This can occur as a result of an infected person expelling droplets as in coughing or sneezing.

**Airborne transmission.** This occurs when diseases are carried from one place to another by air currents.

**Vehicle transmission.** This involves the spread of disease through contaminated items such as hospital equipment.

**Vector transmission.** This occurs when a disease is spread by a vector such as insects or animals. A good example of vector transmission is the spread of malaria by mosquitoes.

The probability of infection is a function of the nature and duration of the exposure. For example, injection of an infectious agent directly into the blood presents a much more serious threat than a brief random encounter with a disease-carrying individual at a distance. In addition, some infections are more aggressive than others.

## **Control of Transmission and Infection**

Cryonics team members are at risk for communicable diseases in three distinct situations: (1) during access of the terminal patient prior to pronouncement of legal death; (2) during cryonics procedures; and (3) during the handling of fluid or tissue samples after a case.

A commonsense approach for infection control during patient assessment is to wear the same kind of protection and follow the same

procedures as those used by medical professionals who are treating the patient. As a general rule, always consult a professional about the health risks associated with a specific patient.

During a cryonics case a distinction should be made between universal precautions and specific precautions. Universal precautions should always be followed for every cryonics case. In practice this means always wearing gloves and scrubs. In cases where there is a high risk of blood splatter and airborne transmission (e.g., surgery and endotracheal intubation), a mask and protective eyewear should be worn. Universal precautions operate from the conservative assumption that the patient is carrying an infectious disease.



*Figure 8-2. Example of face mask and goggles combination.*

In theory it's also possible to be exposed to an infectious disease by handling fluid or tissue samples after a case. Such samples should always be handled as if they could transmit infection.

The first line of defense in infection control is to ensure that people who participate in cryonics cases are vaccinated against the most common infectious diseases (see below). The next step is to ensure that staff members or volunteers with a compromised immune system or specific susceptibility to specific diseases (i.e. high-risk individuals) are excluded from case work. Since fatigue and stress can compromise the immune system, this is an additional argument to encourage good health practices and low levels of stress in cryonics team members.

Other important steps that must be taken to reduce risk of infection and transmission to other team members include hand washing and the use of aseptic technique. A good way to prevent transmission of communicable diseases is to aim for not introducing something to a patient and not receiving anything from a patient. A good 30-second scrub before donning your gloves and another 30-second scrub after doffing your gloves is recommended. If no (clean) station for hand washing is available, alcohol can be applied directly to hands, or disinfected towelettes can be used to clean hands. For major surgical and invasive procedures, double-gloving is recommended.

With prolonged use and handling of various types of equipment it is not unusual for gloves to sustain tears and punctures. Make sure to promptly replace a damaged glove.

Throughout its history, Alcor has always aimed to perform procedures using aseptic technique. Non-invasive equipment should be maintained in a clean state and sterile technique should be used in the case of invasive procedures. For example, a typical transport surgery for washout is performed in surgical gown with sterile gloves and autoclaved surgical instruments. Although a cryonics patient cannot incubate diseases while in biostasis, and even the worst known pathogens are an insignificant medical problem compared with the challenges of revival and rejuvenation, we should avoid introducing bacteria into the circulatory system that could grow during hypothermia and affect later cryoprotective perfusion. Clean and sterile instruments also protect the circulatory system from particulate contamination.

## **Sources of Disease Transmission in Cryonics**

It is important to recognize that reducing the risk of disease transmission in cryonics does not just concern transmission of disease from or to the patient but also between team members.

- Transmission of disease during pre-patient assessment (see above).
- Transmission of disease by direct contact with fecal material during ice water recirculation in the ice bath. Prevention: use the right kind of SQUID device and place a rectal occlusion device in the patient prior to starting CPS and ice-water recirculation. An additional measure is to add a small amount of bleach to the ice bath.
- Transmission of disease by endotracheal intubation and aspiration of fluids. Prevention: wear an additional mask and protective eyewear.
- Transmission of disease by needles and sharps. Prevention: use safe and aseptic technique to prepare, draw, and administer medications and fluids. Take great care in using needles and sharps during transport and always use a sharps container to dispose of used sharps and needles.
- Transmission of disease during surgery for washout and cryoprotective perfusion. Prevention: Wear standard medical outfit for sterile surgical procedures and prevent bystanders from getting too close to the patient.
- Transmission of disease during conduct of washout and cryoprotective perfusion. A major risk factor is splashing of body fluids and perfusate as a consequence of direct contact with the effluent or splashing associated with broken connections in the circuit. Prevention: Wear an additional mask and protective eyewear if working in close proximity to the patient or the

perfusion circuit. Prevent extremely high pressures in the circuit, especially upstream of the circuit filter. Pause the perfusion and replace the circuit filter if pressures become excessive.

- Transmission of disease during transport and handling of fluid and tissue samples. Prevention: Avoid direct contact with the samples and handle with care if there is a specific reason to suspect an increased risk for disease transmission (e.g., in the case of blood samples).

## **Postexposure Protocol**

If a team member suspects having been exposed to an infectious disease, the first step to inform the team leader and the Medical Advisor retained by your organization. If a team member suspects infection by a highly dangerous virus such as HIV, the team member should be immediately transported to a medical facility for rapid antiviral therapy.

## **Communicable Diseases**

Before listing some infectious diseases, we must emphasize two important considerations. First, not all viruses and bacteria have a health-threatening effect, or even noticeable symptoms. It is common knowledge in microbiology that the human body is the home of many bacteria and viruses, some of which actually assist the body in doing its job. Of course, knowledge of whether a virus is innocent tends to change over the time as we learn more about its long-term effects. For example, the herpes simplex virus 1 (HVS-1), which is present in the body of more than 50% of the population, has recently been associated with the etiology of sporadic Alzheimer's disease.

Second, many infectious diseases that are among the top killers worldwide are relatively unusual in modern Western countries such as the United States. However, immigration and global travel can reintroduce these diseases to the United States. The rarity of many third-world diseases in the modern world should never lead to complacency regarding protection.



Also note that as a general rule, cryonics patients have usually undergone a prolonged period of physical decline, with associated immune depression and various infections, within a medical setting. Treatment facilities such as hospitals are particularly fertile grounds for spreading infections due to high concentrations of sick and elderly patients with compromised immune systems.

The World Health Organization (WHO) listed the following 10 leading infectious causes of death worldwide in 2001:

1. Respiratory infections
2. HIV/ AIDS
3. Diarrheal diseases
4. Tuberculosis (TB)
5. Malaria
6. Measles
7. Pertussis
8. Tetanus
9. Meningitis
10. Syphilis

### *HIV/AIDS*

Human Immunodeficiency Virus (HIV) is a blood-borne disease that causes Acquired Immunodeficiency Syndrome (AIDS), which is potentially fatal. It is often sexually transmitted. There are no vaccines or cures for HIV/AIDS at this time, although the progression of HIV to AIDS has been mitigated by a combination of anti-retroviral therapies. Unlike many other dangerous contagious diseases, infection with HIV does not produce acute life-threatening symptoms. As a consequence, people can be infected with HIV without showing visible signs. Since HIV cannot be transmitted by air or

casual contact, the greatest risk for exposure to the HIV virus for cryonics team members is by exposure to blood or needle sticks.

### *Hepatitis*

Hepatitis means inflammation of the liver and can be the consequence of a number of causes including viruses, alcoholism, toxic chemicals, and drugs. It can manifest itself as an acute or chronic condition. The most noticeable symptom is jaundice, or yellowing of the skin.

Distinctions are made between hepatitis A, B, C, D, and E. Hepatitis A and hepatitis E are transmitted by the fecal-oral route and do not produce a chronic condition. Hepatitis A can be prevented by vaccination, good hygiene and sanitation. Like HIV, hepatitis B can be transmitted through body fluids and can produce chronic hepatitis.

There are approximately 200,000 new hepatitis B infections a year, and EMS personnel have an elevated risk. They will benefit from vaccination.

In the United States, around 2% of the population is infected with hepatitis C, and it is the most common chronic blood-borne infection, spread through body fluids and blood. There are currently no vaccines against this virus. Prevention measures for emergency health care providers consist of universal precautions and the use of sterile needles.

Hepatitis D can only be transmitted and propagated in the presence of the hepatitis B virus, and can produce chronic liver conditions. The best way to protect oneself against hepatitis D is to get the hepatitis B vaccine and take all the precautions against transmission of hepatitis B.

### *Tuberculosis (TB)*

Tuberculosis is a bacterial disease that can manifest itself in dangerous and lethal health problems. It can be acquired by airborne or droplet transmission. TB is more prevalent in non-Western countries, but the AIDS epidemic, and resistant strains, have made it a great concern for those practicing medicine. If TB is suspected or diagnosed, each team member should wear a HEPA mask.

### Other Diseases

Other infectious diseases that can be transmitted through respiratory secretions and airborne exposure include meningitis, chickenpox, and (German) measles. If a cryonics stabilization case is conducted in a third-world country, extra precautions are advisable—for example, protection against malaria. Also, information gathering is required prior to deployment.

As a general rule, cryonics standby team members should never participate in a case without prior consultation with medical caregivers, family members, and the patient about the presence of contagious diseases.

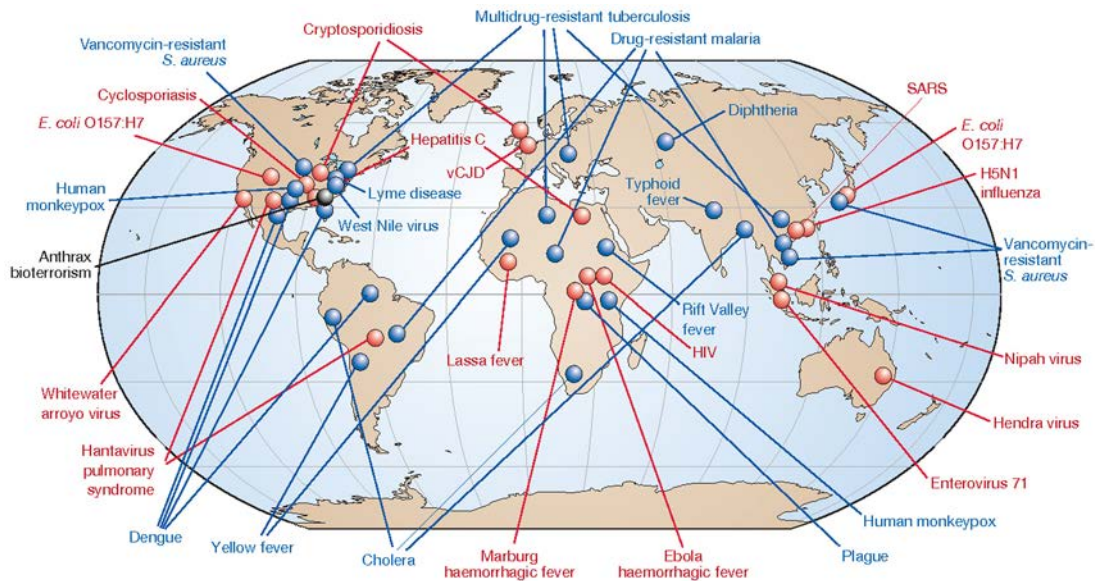

Figure 8-3. Emergent diseases (red) and re-emergent diseases (blue), worldwide.  
Source: Nature volume 430, pages242–249(2004).

### Vaccinations

Immunity against infectious diseases can be conferred by prior exposure and successful elimination of the pathogen, or by intentional vaccination.

Recommended vaccinations for cryonics staff members who participate in cases, and standby volunteers, include:

- Tetanus, Diphtheria and Cellular pertussis

- Hepatitis A
- Hepatitis B
- Influenza
- Pneumococcal vaccine
- Varicella (chickenpox)
- MMR (measles, mumps, rubella)
- PPDB
- Measles
- Rubella
- Chickenpox
- Meningitis
- Bacillus Calmette-Guérin (TB)

The importance and nature of these vaccines can change over time and a cryonics organization should always make efforts to remain informed about emerging epidemics and new vaccines.

## **AIDS Cases in Cryonics**

We know of at least two cases at Alcor where the organization needed to stabilize a patient with advanced symptoms of AIDS (case A-1036 and case A-1399). In A-1036 the presence of AIDS was used as justification by hospital administrators to prevent Alcor from gaining access to the patient. In a brief submitted to the judge they wrote:

Mr. Roe's and Alcor's requests would violate hospital procedure for the handling of the remains of AIDS patients, whose body fluids are infectious. The customary procedure for handling such remains is to seal them in a nonpermeable shroud marked "communicable disease" and have a mortician

remove the body from the hospital in a sealed shroud, without performing any procedures on the body at the hospital.

Ultimately, Alcor prevailed in the legal fight and a report is available on the organization's website. This episode does highlight that the presence of a dangerous infectious disease can not only provide health challenges for team members, but can also present challenges in obtaining access to the patient. It is important that a cryonics organization anticipates and is equipped to deal with such circumstances.

Case A-1039 was cryopreserved on April 11, 1993. As can be seen in the photograph in Figure 8-4, Alcor team members took extra precautions to protect themselves against transmission of the HIV virus. In this case, bleach was also incorporated in Alcor's AIDS precautions because of its property to kill the HIV virus.



*Figure 8-4. Stabilization procedures for an AIDS patient.*

In the unlikely event that a patient with cryonics arrangements is a carrier of a very dangerous and highly communicable disease, a cryonics organization may omit procedures such as stabilization and cryoprotectant

perfusion before freezing. In extreme cases, especially if required by law, cryopreservation may not be possible.

## **9. Cardiopulmonary Support: Circulation**

Cardiopulmonary resuscitation, often referred to as CPR, was developed to resuscitate patients who have no respiration or pulse but have not been pronounced legally dead.

In a cryonics case where death has been pronounced, we do not wish to promote resuscitation. We have the more limited objective of minimizing cerebral injury by circulating oxygen, glucose, and anti-ischemic medications in the blood stream. We will refer here to this procedure as *cardio-pulmonary support*, or CPS, to differentiate it from CPR.

This section focuses on CPS that has the primary goal of promoting circulation of the blood by applying external chest compressions to reduce the volume of the chest cavity and squeeze the heart.

Section 10, which follows, will focus on CPS that has the primary goal of ventilating the lungs by forcing air or oxygen down the trachea after a patient has been intubated.

In modern cryonics practice, it is preferable to ventilate cryonics patients receiving CPS with air rather than oxygen due to studies showing that patients resuscitated after cardiac arrest in conventional medicine suffer less brain injury if ventilated with air during the post-resuscitation interval. Pure oxygen may worsen post-ischemic injury caused by free radicals. See Section 10 for additional details.

### **History**

In 1874, the German surgeon Moritz Schiff is reported to have used open-chest cardiac massage on an animal model in the physiology laboratory at the Institute of Advanced Studies in Florence, Italy. Schiff had been comparing the effects of anesthetics, and showed that he could induce circulation by

massaging the heart after cardiac arrest had been caused by chloroform. As the anesthetic started to wear off, the heart resumed beating spontaneously.

During the early 1900s, this procedure was used intermittently on human patients, initially with mixed results. Today heart massage is still an option during surgery where the chest has already been opened, or for patients in a hospital who have a chest incision that can be reopened quickly. It is usually done in conjunction with medications and a defibrillator, and has the advantage of providing more cardiac output than external, closed-chest cardiac massage.

The concept of closed-chest massage was explored in Germany in the late 1800s, but, surprisingly, fell into disuse until being revived decades later by William Kouwenhoven, a retired electrical engineer who was investigating the use of electric current to defibrillate the heart at Johns Hopkins University. After Kouwenhoven noticed that merely placing a heavy weight on the chest of an anesthetized dog would elevate its blood pressure, he developed a method to apply chest compressions with a success rate of about 70 percent for resuscitation after cardiac arrest.

In 1960, when Kouwenhoven was 74, an account of his work was published describing how the heel of one hand should be placed on top of the sternum, the other hand should be placed on top of the first hand, and firm pressure should be applied downward approximately 60 times per minute. Today, the goal is to apply 100 to 120 compressions per minute, but the basic procedure remains the same.

The use of chest compressions was endorsed by the American Heart Association in 1963, and was popularized by Peter Safar, who is often referred to as the “father of CPR” even though the technique was developed collaboratively.

Safar insisted that doctors should not be the only people allowed to administer chest compressions, and his advocacy was successful despite strong opposition from medical professionals. A similar situation exists in cryonics today where volunteers may be encouraged to provide some kind of cryonics first response (chest compressions, cooling, and administration of anti-clotting medications) if a professional standby team cannot respond in a timely fashion.



CPR is now recognized in the United States and most other countries as an acceptable intervention that anyone with minimal training may administer, without fear of legal repercussions, in an effort to revive a victim of cardiac arrest. There is no statutory limit on the length of time for which CPR may be applied.

## **CPS Scenarios**

Four scenarios (two of them ideal, and two of them non-ideal) may help to illustrate the role that chest compressions may fill in a cryonics case.

### *Cardiac Arrest Scenario with Favorable Outcome*

A member of a cryonics organization suffers unexpected cardiac arrest at home in his kitchen. Half an hour passes before he is discovered by two relatives. One of them begins to administer chest compressions while the other calls the cryonics organization and a local team of paramedics. The relatives take turns doing vigorous chest compressions, with ventilation of the lungs, for the next hour. The patient shows no vital signs. When paramedics arrive, chest compressions are interrupted long enough to allow attempts to restart the heart with a defibrillator. These attempts are unsuccessful. A phone call to the patient's physician confirms a recent medical history of cardiovascular problems. An autopsy will not be necessary. Death is pronounced, and chest compressions are continued by family members while ice is placed around the head. Standby team members from a local group of cryonicists arrive and continue chest compressions while administering medications and moving the patient to a local mortuary, where stabilization is completed prior to transport. Chest compressions probably played an important role in this case.

### *Disease Scenario with Favorable Outcome*

A patient who has made arrangements to be cryopreserved after death has checked into a hospice less than 10 miles from the cryonics organization. The patient is dying from problems associated with metastatic cancer. Standby personnel are present. Relatives are also present, but have been fully informed and are not hostile to the procedures. A hospice nurse has agreed to honor the

patient's wishes for cryopreservation. Eventually, cardiac arrest occurs. The hospice nurse has authority to pronounce legal death, and does so. Immediately, the team members apply chest compressions and start to administer medications while the patient is moved by a purpose-built transport vehicle to the cryonics facility, where the operating room has already been made ready for cryoprotective perfusion. Here again, chest compressions are an important part of the intervention.

#### *Four Accidental Death Scenarios with Unfavorable Outcomes*

A man suffers cardiac arrest in his home workshop. He languishes for an hour or more at room temperature, without any intervention, because:

He lives and works alone, or

People who find him don't know how to do CPR, or

They do chest compressions for 10 minutes and then give up, or

Other severe injuries have occurred (for example, massive bleeding)

which encourage emergency personnel to feel that CPR is pointless.

#### *Four Disease Scenarios with Unfavorable Outcomes*

A person who is hospitalized suffers a stroke. The heart continues beating, but respiration does not return spontaneously. The patient is placed on a ventilator and remains in a coma. The stroke causes brain damage that is irreversible because:

Hospital protocol requires a time-consuming MRI before life support can be discontinued and cryopreservation personnel can intervene, or

Relatives refuse to allow removal of the ventilator, or

Standard hospital procedures suggest an autopsy, and no one objects to this, or

The patient has left no instructions for procedures under these circumstances.

The above examples are all based on various actual cryonics cases. While underlining the obvious conclusion that ideal scenarios are rare compared with non-ideal scenarios, they also indicate that difficult judgment calls may be necessary when deciding whether to apply CPS.

## **Advisability and Duration of CPS**

The amount of warm ischemic time that has elapsed before pronouncement will determine whether we wish to apply minimal chest compressions (just enough to circulate an anticoagulant) or prolonged, vigorous chest compressions, continuing throughout administration of a full range of meds, up to the point where blood washout begins. Explaining this scenario persuasively to medical personnel or relatives is important but can be challenging and may take valuable time.

## **Instructing Bystanders to Administer CPS**

The difference between a good case and a suboptimal case may depend on next-of-kin who know how to administer chest compressions or can receive instructions over the phone from EMS (911 call) if medical resuscitation may still be possible and is desirable (no terminal illness), or from a well-informed employee at a cryonics organization if legal death has already been pronounced. A family member who has just discovered the lifeless patient may be too distraught to provide help unless telephone advice is calm, patient, compassionate, and precise.

In one Alcor case, the son of a member called for advice just minutes after he had found his father with no heartbeat and had called paramedics. The paramedics gave up trying to resuscitate the member while the son was on the phone with Alcor. The son stated that his father, who was a doctor, had a vial of heparin and had asked for it to be injected in case of death. After an autopsy waiver was obtained from the coroner's office, the son was advised how to do this in absence of blood pressure, and then administered sufficient chest compressions to circulate the medication. Patience and kindness were essential to maintain assistance from the son. The case later perfused successfully.

## **Unknown Outcome**

Anyone can learn to do chest compressions in a brief, low-cost class provided by a county health department or fire department. However, chest compressions have little value unless they are administered very vigorously, as soon as possible after cardiac arrest, and without significant interruptions. Strength and stamina are essential if the compressions are done manually.

The outcome of chest compressions is unpredictable. Even when they are administered according to the usual guidelines, they cannot create normal blood flow and pressure. Consequently, manual CPS alone may fail to prevent brain damage, even under relatively ideal circumstances. For this reason, vigorous chest compressions should always be augmented by induction of rapid cooling and administration of neuroprotective medications.

Normal Mean Arterial Pressure (MAP) is between 70 and 110 mmHg. MAPs of ~ 50/ 60 and higher are associated with cerebral viability. Manual CPR is rarely higher than 40 mmHg. Conventional CPR typically generates around one-third to one-quarter of normal cardiac output. This is generally not sufficient to meet cerebral energy demands and should only be used as a bridge to defibrillation (in conventional medicine) or blood washout (in cryonics).

In cryonics patients, cardiac output may be further compromised because many patients are atherosclerotic and/or have gone through a prolonged period of shock or multiple organ failure prior to pronouncement of legal death. However, in ideal cases, securing cerebral viability may still be feasible if aggressive multimodal techniques are used. An example of such a scenario would be a case where the team is able to intervene immediately after pronouncement of legal death; circulation and ventilations are promptly restored using a mechanical device capable of active compression-decompression CPS; a respiratory impedance valve is attached to the airway to improve venous return to the heart; blood pressure is supported by vasopressin and/or epinephrine; and rapid administration of neuroprotective medications and induction of hypothermia are started to protect the brain until blood substitution or cryoprotection is possible.

## **Risk of Resuscitation**

If chest compressions are administered very quickly after cardiac arrest, and the patient had a rare neurological adaptation to low cerebral blood flow as a consequence of chronic vascular disease, there is a theoretical risk of restoring consciousness. We are not aware of any cryonics case where this has actually occurred, bearing in mind that terminal patients typically lose consciousness or become semicomatose before the heart stops beating. Furthermore, general anesthesia is a side effect of the anesthetic administered to decrease cerebral metabolism for neuroprotection during cryonics stabilization procedures. Cardiac autoresuscitation during CPS is prevented by administration of sodium citrate for anticoagulation. Citrate causes cardioplegia by chelating calcium.

## **Conventional Application**

The following steps for administering chest compressions incorporate standard guidelines from the American Heart Association.

1. First be sure that the heart has stopped beating. If you are not experienced in taking a pulse, ask someone who is. Respect the judgment of any professionally qualified nurse, doctor, EMT, or paramedic. A weak pulse may be easy to miss.
2. The patient should be on a low, flat, rigid surface.
3. Locate the xiphoid process, which is a tab of bone extending downward from the junction of the ribs at the front of the body. From this point, shift your hand toward the head of the patient by a short distance equal to the width of two fingers pressed together. This is the lower limit of the area where you need to apply pressure. In Figure 9-1, the xiphoid is shown in red while the safe area for chest compressions is shown in green. Do not press on the xiphoid process itself. If it breaks off, it can puncture or lacerate the diaphragm, or may damage the liver, causing a hemorrhage.

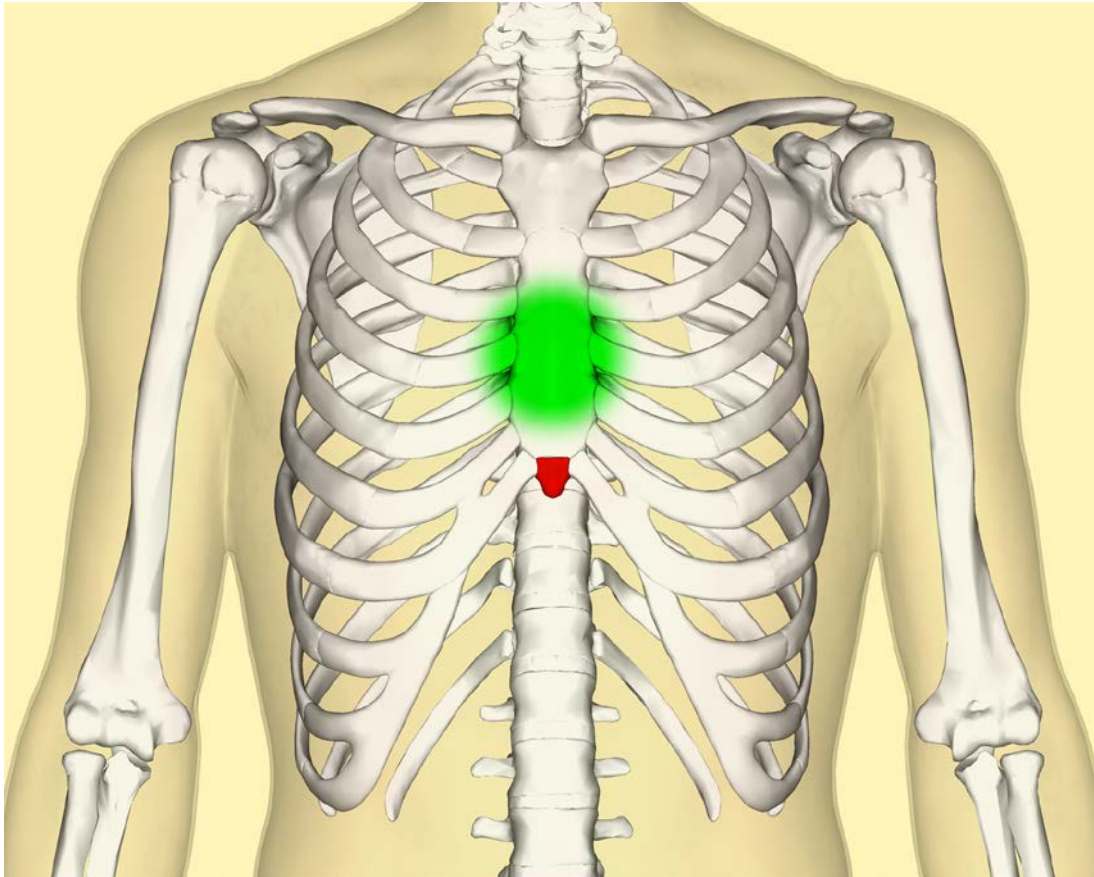

*Figure 9-1. Chest compressions can be administered in the green area, while avoiding the xiphoid process, colored red.*

4. While kneeling or standing over the patient, extend both arms with elbows completely straight.
5. Bend one hand up toward you and press the heel of this hand in the safe area you have located above the xiphoid process. Interlock the fingers of your second hand with the first, so that the second hand presses down on the back of the first hand. The correct position is shown in Figure 9-2.



*Figure 9-2. Correct use of the hands to administer chest compressions.*

6. Press down sharply, with all your strength, with both hands, approximately 100 times per minute, while keeping your arms straight and rigid to transmit the momentum of your body to the patient.

## **Mechanically Administered Chest Compressions**

Under ideal circumstances, immediately following pronouncement of legal death, CPS may be administered by cryonics personnel for up to 90 minutes to maintain blood circulation that will metabolically support the brain and speed patient cooling in an ice bath. This period is much longer than is common when CPR is used in conventional medicine.

Administering vigorous compressions manually for such a long time will be physically impossible for most people, and is a challenge even when two or more people take turns. This was recognized in the early days of cryonics when machines such as the Westinghouse Iron Heart or Brunswick Heart Lung Resuscitator were employed to automate the process of administering chest compressions and ventilations.

The Alcor Life Extension Foundation was a relatively early adopter of the Michigan Instruments Thumper, powered by compressed gas. Subsequently Michael Darwin introduced a specially modified version of the

Thumper that would apply suction to the chest on the up stroke as well as positive pressure on the down stroke.

Suspended Animation Inc. developed its own variant of the Thumper, and resold one to the Cryonics Institute together with an ice bath (see Section 11, Induction of Hypothermia). Alcor and Suspended Animation subsequently acquired electrically powered devices for chest compressions. Details are provided below.

## **Termination of CPS**

Alcor's current protocol is to continue CPS until a temperature of 20 degrees Celsius is reached or when it is determined that the pace of cooling is becoming so slow that performing surgery for washout is the preferred approach. The rationale to continue chest compressions until this temperature is reached is that deep hypothermia allows for surgery to proceed without causing additional brain damage. If there is no washout or cryoprotection, in principle CPS can be continued until the patient reaches the temperature of water ice. There are few cases where such a practice has been documented.

## **Prolonged Mechanical CPS and Pulmonary Edema**

As the duration of (mechanical) CPS increases, its efficacy decreases. Prolonged CPS in cryonics is also associated with a pink frothy foam coming from the patient's mouth or the endotracheal tube. Explanations for this phenomenon include the type of chest compressions (normal vs active compression-decompression CPS), ischemia-induced swelling and damage to the lungs, anti-coagulation, and the administration of fibrinolytics. To address these concerns and incorporate recent research, Alcor has deleted streptokinase from its initial stabilization medications list and added it to the washout or first cryoprotectant perfusion flush instead.



## **Michigan Instruments Devices**

Figure 9-3 shows two early prototypes of chest-compression devices installed in a hospital setting, both using pneumatically powered pistons. Michigan Instruments founder Clare Barkalow tested similar equipment before marketing model 1001 of his own device in 1964. Model 1002 was added as an adjunct system providing ventilation, while model 1003 was marketed in 1969 as the M. I. L. Life Aid, combining chest compressions and ventilation in one unit. In 1972, model 1004 was the first to be named a “Thumper” and added an adjustment for compression depth.

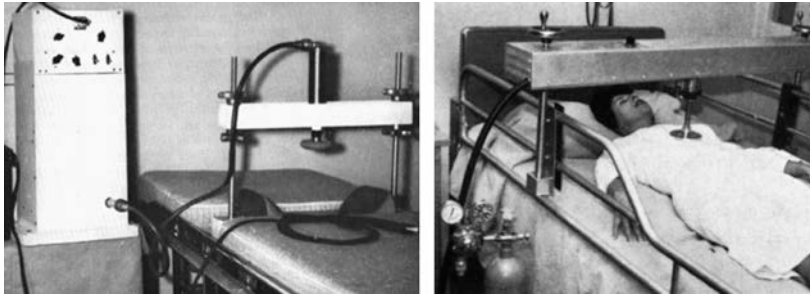

*Figure 9-3. Early experimental devices to apply chest compressions.*

Minor modifications were incorporated in model 1005, marketed in 1985. This model was purchased by Alcor and used in cryonics cases. Figure 9-4 shows it in low-resolution photographs taken for a transport manual.

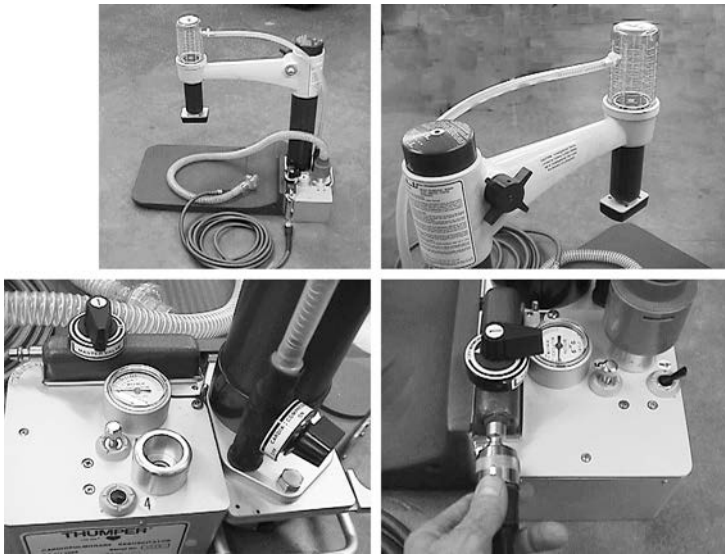

*Figure 9-4. Photographs from an Alcor transport manual showing a Thumper used in cryonics cases.*

In 1998, model 1007 of the Thumper was introduced, shifting the control knobs from the base plate to a small panel at the end of the movable arm that carries the piston assembly. Initially model 1007 was offered in two variants, 1007CC and 1007CCV. However, the 1007CCV has been replaced by the model 1008, which has dropped the Thumper name and is marketed as the Life-Stat. Unlike its predecessors, which were entirely mechanical, the Life-Stat includes some simple timing electronics. These are powered by a pair of 9V batteries.

The Thumper 1007CC is a simplified product that runs at a fixed rate of 100 chest compressions per minute. Unlike all previous models from Michigan Instruments, it does not ventilate the patient. Figure 9-5 shows the 1007-CC with its parts identified by the manufacturer, and Figure 9-6 shows the very simple control panel.

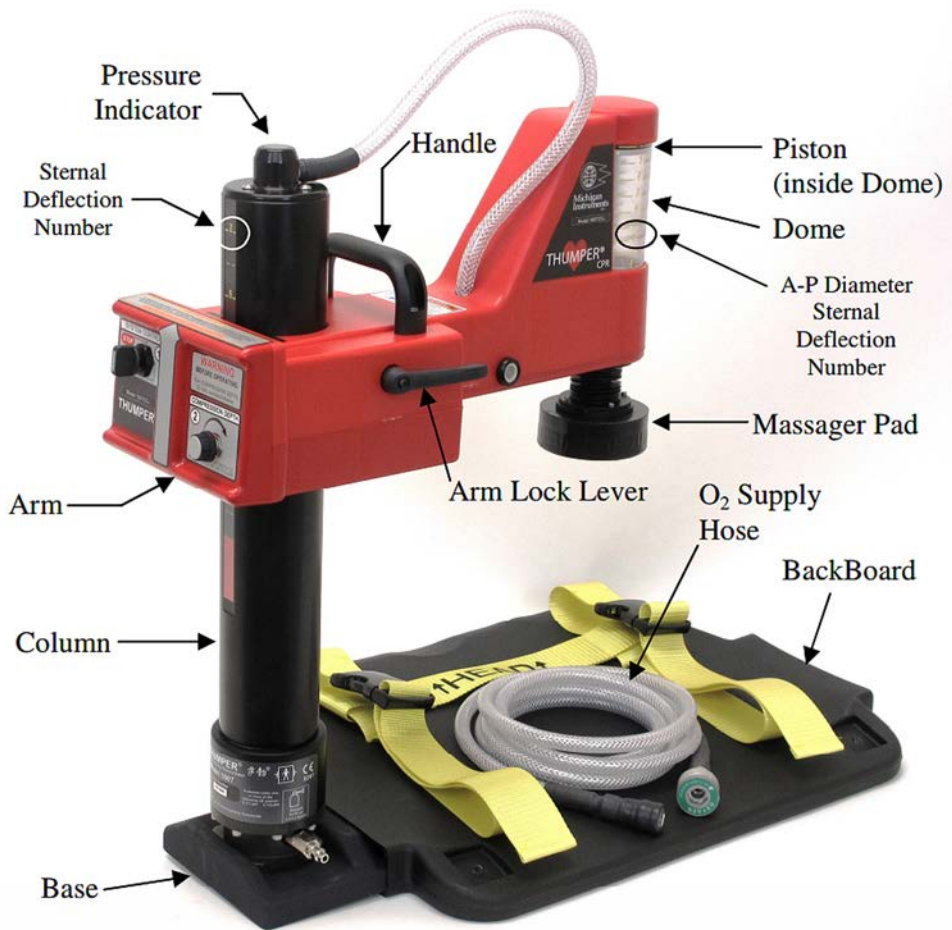

Figure 9-5. The Michigan Instruments Thumper model 1007-CC, which does not administer ventilation cycles.



Figure 9-6. Control panel for the Thumper model 1007-CC.

If the Life-Stat is used, and the patient has been intubated, ventilation can be supplied automatically on either a 30:2 basis (30 chest compressions, pausing to provide 2 cycles of ventilation) or a “CCV” basis (continuous chest compressions while delivering 8 to 9 ventilation cycles at the same time). The unit can be set up by the manufacturer to provide either 100 or 120 compressions per minute. The buyer must make this choice at the time of purchase, as it cannot be adjusted later. Figure 9-7 shows the Life-Stat with its parts identified by the manufacturer, and Figure 9-8 shows the control panel.



Figure 9-7. The Michigan Instruments Life-Stat, model 1008.



Figure 9-8. Control panel for the Life-Stat.

Chest compressions on both of these models and their predecessors from Michigan Instruments are administered with a gas-driven piston mounted on an arm that extends over the patient's chest. A shaft from the piston extends downward to a "chest massager" pad that must be located immediately above the xyphoid process. The arm of the device is lowered until the "massager" touches the chest. The operator then locks the arm in place by turning a lever to clamp the arm to a supporting column.

Before starting the device, it is essential that a dial controlling compression depth must be set to zero. After chest compressions are initiated, the dial is turned up until compressions reach the desired depth, shown by a pointer on a scale

Michigan Instruments products offer some advantages:

- **Simplicity.** The component parts of a Thumper are easy to understand
- **Manually adjustable.** Compression depth can be set by the operator.
- **High impulse.** Compressed gas enables a strong downward force.
- **Ventilation.** The same gas that drives the Thumper can ventilate the lungs (in all models except 1007CC).

However, there are significant disadvantages.

- **Limited duration.** A pair of E-size oxygen cylinders, which can be carried in a custom-designed backpack (shown in Figure 9-9), may last for less than 10 minutes. An H-sized cylinder of oxygen may last between 20 and 30 minutes.
- **Limited portability.** An H-size cylinder is usually available on an ambulance, but it cannot be moved easily from the vehicle as it weighs too much for one person to lift and must be handled with care.
- **Accidents with compressed gas.** If the valve at the end of a gas cylinder is broken off, the cylinder will behave literally like a rocket.
- **Dangerous oxygen accumulation.** If used in a confined space, such as the interior of an ambulance, without adequate ventilation, the large volume of oxygen released from a Thumper creates some risk of an oxygen-fuelled fire. For biological reasons, modern preference is to use compressed air instead of oxygen, which as a side benefit does not have this risk.
- **Vulnerable to error.** An operator must remember to turn the compression-depth dial to zero before starting the equipment. Injury may result if this step is omitted.
- **Noise.** The Thumper, as its name implies, cannot be used discreetly. The release of compressed gas while valves open and close creates a series of hissing, clicking, and hammering noises.



*Figure 9-9. A backpack for carrying small oxygen cylinders.*

## **Use of the Thumper in Cryonics Cases**

The Thumper design was not entirely compatible with a portable ice bath, because the high sides of the bath prevented the base plate from being pushed under the patient from the side. As a compromise solution, the frame of an ice bath from the 1980s typically included a low section to allow Thumper access. (See Section 11 for a detailed pictorial history of ice baths.)

In a remote location, obtaining oxygen or compressed air to power the Thumper could be a challenge. Bearing in mind that medical gas requires a doctor's prescription, welding gas was sometimes purchased as a substitute, from a local industrial supplier if one was available (they were usually closed on evenings and weekends). A transport manual written by Michael Darwin suggested tapping into oxygen supply outlets in hospital rooms, and included pictures of adapters for this purpose. We have no information on how often this was actually done.

The MARC cart designed by Hugh Hixon at Alcor included two mid-sized oxygen cylinders to power a Thumper. Although they were made of aluminum, they increased the weight of the cart to the point where lifting it over a curb to get it onto a sidewalk was problematic. (The MARC is discussed in Section 11.)

Overall, gas supply has been the biggest problem for Thumper models.

## **Ambu CardioPump and ACDC Thumper**

The CardioPump, shown in Figure 9-10, is a small, simple, unpowered device that is held between two hands while the user presses down to administer chest compressions via a suction cup. If the operator pulls up on the CardioPump after each down stroke, some suction can be induced inside the chest cavity, potentially enhancing blood circulation.

The CardioPump has some advantages:

- Some people prefer its use over unassisted manual CPR over long periods.
- A simple gauge shows the pressure exerted with each stroke.



- The suction cup improves cardiac output.

But, there have been some disadvantages.

- Because there is no power assistance, users still get tired.
- Some people feel that the CardioPump is actually more tiring than simple manual chest compressions administered directly with the hands.

The CardioPump was not FDA-approved when it was first introduced, and had to be imported from Canada.



*Figure 9-10. The Ambu CardioPump.*

In 1996, Michael Darwin commissioned Michigan Instruments to build a customized version of the Thumper that would have a piston shaft terminating in a suction cup instead of a massager. The company declined to assemble this configuration, because the suction cup was not FDA-approved. Therefore the Thumper was delivered with a bare piston shaft with a groove at the end, enabling Alcor to push-fit the suction cup on its own initiative. Together with other features, this created what Darwin referred to as the “ACDC Thumper,” referring to its ability to administer Active Compression and Decompression. In Figure 9-11, Darwin is shown setting up the ACDC Thumper, probably during his time as president of Biopreservation, Inc, a service provider that contracted with CryoCare Foundation.

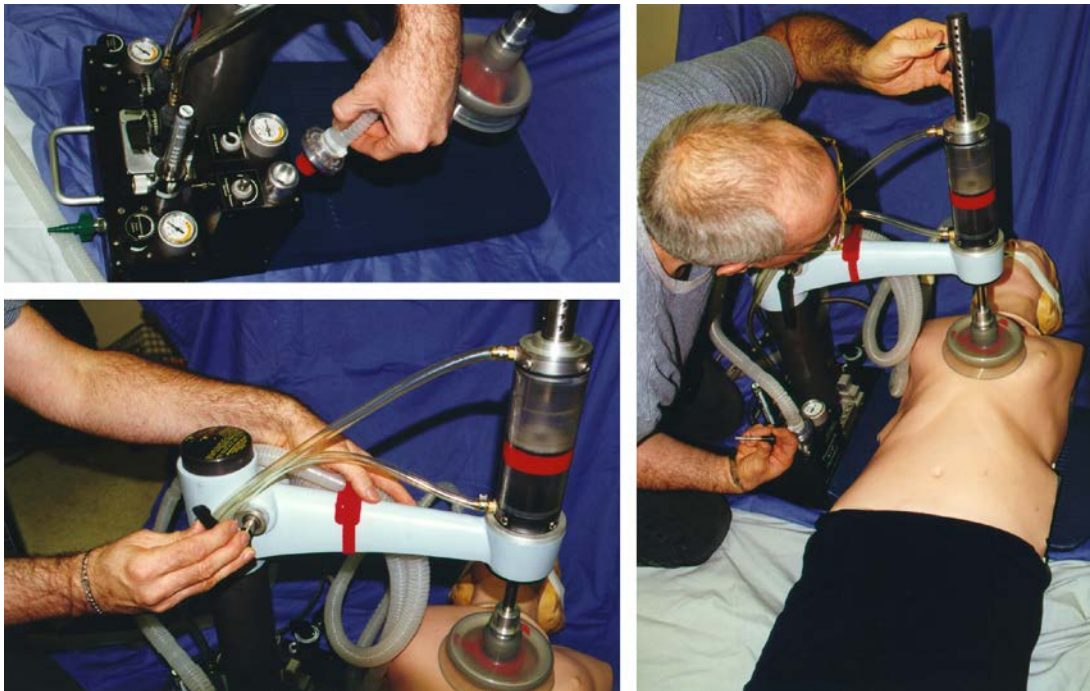

*Figure 9-11. Michael Darwin setting up the ACDC Thumper built to his specifications.*

Michigan Instruments never did add a suction cup to any of their mass-produced models, but it has been included on the LUCAS system and on the Suspended Animation Thumper (both described below).

## **Suspended Animation Thumper**

In 2003 David Shumaker, David Hayes, and Mike Quinn developed a new portable, collapsible ice bath which had legs raising it to waist height when fully assembled. They commissioned Michigan Instruments to build four Thumpers custom-designed to clamp across the rails of the new ice bath. The aluminum base of the ice bath eliminated the need for a base plate for the Thumper, and the increased length, width, and depth of the bath made it suitable for obese patients.

Figure 9-12 shows the Suspended Animation Thumper on an accessory stand that could be used if the Thumper was not straddling an ice bath. In Figure 9-13, the oxygen intake is visible above an outlet for ventilating the lungs via endotracheal tube. In Figure 9-14, controls can be seen for making independent adjustments to compression depth, decompression force, and ventilation volume. The system is switchable between continuous compressions (no ventilation) and 5:1 ratio of compression cycles to ventilation cycles. All of these features were implemented mechanically, powered by gas pressure. The unit did not contain any electronics.

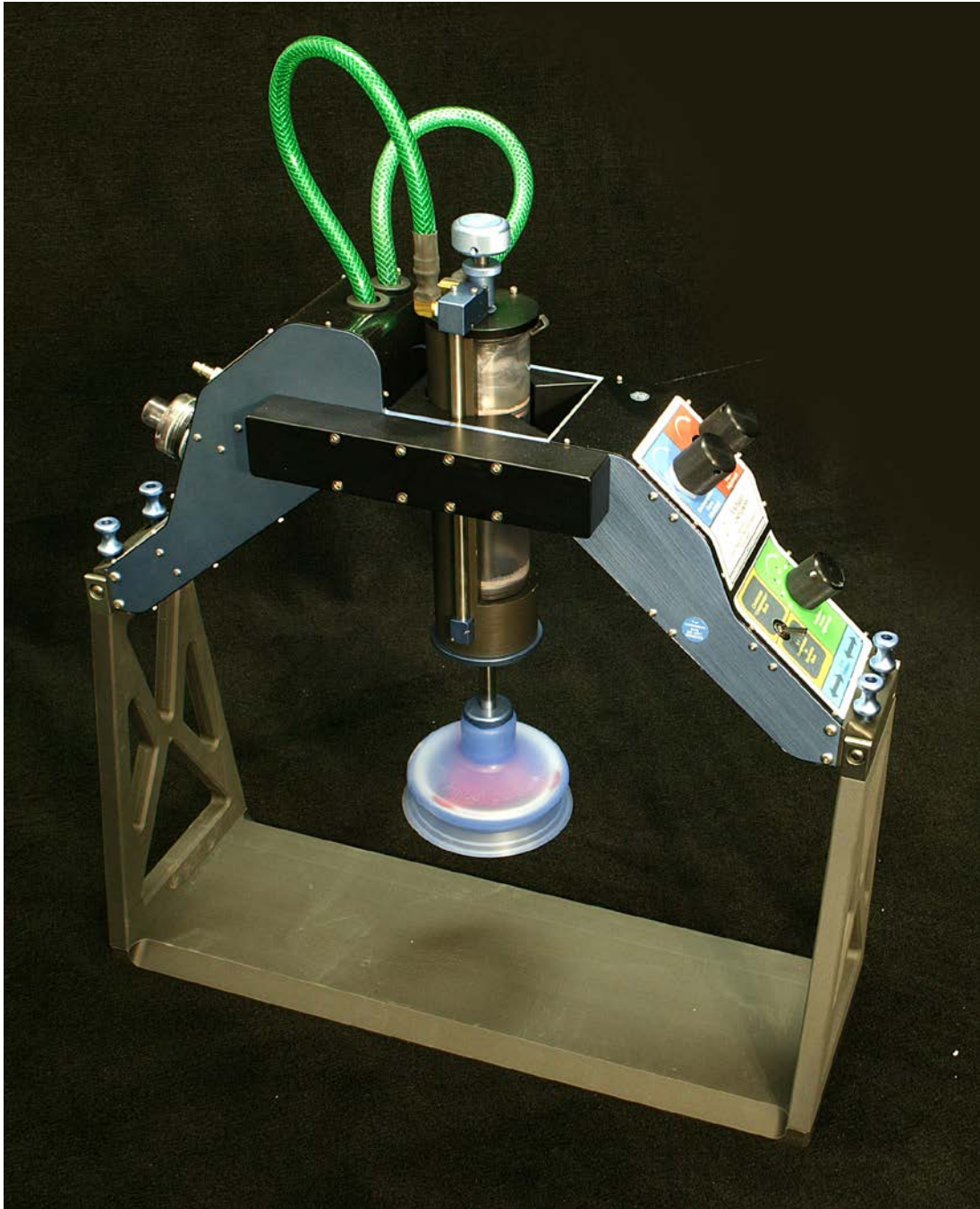

*Figure 9-12. The variant of Darwin's ACDC Thumper commissioned by Suspended Animation, Inc, shown here on an accessory stand.*



Figure 9-13. Gas intake and outlet on the Suspended Animation ACDC Thumper.



Figure 9-14. Controls on the Suspended Animation ACDC Thumper.

Michael Darwin was a consultant for Suspended Animation while this device was developed by Michigan Instruments. Only four were built. Darwin fully understood the various adjustments, but other operators had trouble with their complexity, especially in stressful situations. The device was used in two cases managed by Suspended Animation before it was superseded by the Autopulse (described below).

Eventually one of the Suspended Animation Thumpers was sold to the Cryonics Institute. It was still featured on the company web site as of 2017.

## **LUCAS Manufactured by Jolife**

LUCAS is an acronym derived from Lund University Cardiopulmonary Assist System. It was developed by Jolife, a Swedish company that has since been acquired by Physio-Control, Inc.

In 2002, at Alcor, Mathew Sullivan ran across a reference online to the LUCAS, which was being launched in Europe. Photographs and sales literature showed that it was equipped with a suction cup and suggested that it would be lighter and simpler than the Thumper, while its small detachable baseplate would allow it to be used in an ice bath without requiring a lowered section in the side rail.

The LUCAS was not yet FDA-approved, and its future in the United States was uncertain. Charles Platt, who was then Director of Cryopreservation Services for Alcor, contacted the manufacturer in Sweden and negotiated the sale of one unit to Alcor for \$20,000, after he signed an agreement that it would not be used on any living person.

The LUCAS turned out to be elegantly designed and easy to use, and was Alcor's CPS device of choice for many years. It did not include any provision for ventilating the lungs, but the manufacturer claimed that chest compressions alone provided sufficient passive ventilation. A view of the LUCAS that Alcor acquired is shown in Figure 9-15.



*Figure 9-15. The first LUCAS purchased by Alcor.*

The primary disadvantage of the LUCAS was that it was still a gas-powered device, requiring heavy oxygen or compressed air cylinders that were



difficult to transport and not always available in remote locations. In addition, the frame of the LUCAS appeared to prevent its use on obese patients. When the manufacturer was queried about this, a representative responded with a humorous and unhelpful comment about the average body weight of Americans vs. Scandinavians.

Late in 2006, the LUCAS finally received FDA approval. It was followed in 2009 by the LUCAS 2, which closely resembled the first model but was electrically powered. It was lighter, quieter, and could run from its own battery, or from a car battery or 110VAC via external adapters. It also allowed a little more vertical room between its suction cup and baseplate, as a concession to obese patients. A photograph of the LUCAS 2, alongside its soft carrying case, is shown in Figure 9-16.



*Figure 9-16. The LUCAS 2 became a standard item in Alcor standby work.*

The LUCAS 2 included a provision to operate in 30:2 mode, meaning that it would provide chest compressions for 30 cycles, followed by a pause for 2 cycles during which the operator could supply ventilation manually. Unlike the electrically powered Autopulse (see below), the LUCAS 2 could be used in an ice bath without modification, as its electronics were at the top of the unit, a safe distance from water in the bath.

Using the LUCAS 2 is relatively simple compared with early versions of the Thumper (and is almost identical to the procedure for the LUCAS 1). The baseplate, referred to as a back support and colored yellow in Figure 9-16, is placed under the patient. After the operator has checked that the suction cup is fully retracted, the upper portion of the LUCAS is lowered until it clicks into place with the back support. The operator presses the Adjust button, which allows the suction cup to be lowered manually into contact with the chest above the xiphoid process. The operator now presses the Pause button. Internal electronics readjust the height of the cup optimally, if necessary. The user now presses either the Active button for continuous compressions or the Active 30:2 button for compressions that pause to allow manual ventilation.

The operator must check the LUCAS frequently to make sure that its position remains correct, and to monitor the battery charge indicator. Otherwise, the device is designed to run itself without further intervention, and supposedly optimizes its own depth of its own compressions.

A stabilization strap may be added behind the patient's neck while the LUCAS is running, anchoring it so that it is less likely to shift during operation. If the patient will be relocated (which is likely during a cryonics case), the wrists can be anchored to the support struts of the LUCAS using Velcro straps that are provided.

The LUCAS 3 was introduced in 2017 and stores detailed data from each use, which can be downloaded via a Bluetooth connection and printed in nicely formatted charts. This feature would be useful for case report writing and quality control, especially in cases where chest compressions may have been omitted or interrupted. The device is sold in a hard-shell polycarbonate case, unlike the soft case of the LUCAS 2. It also has provision to be recharged without removing it from the case. See Figure 9-17.



*Figure 9-17. The LUCAS 3 is supplied with a hard-shell carrying case.*

By 2017, an active market had developed for second-hand LUCAS 2 devices. Alcor bought seven of them, and it is now a standard item in Alcor standby kits.

When former Alcor Medical Response Director Josh Lado was asked about the issue of accommodating obese patients, he responded that in his experience, seeing LUCAS devices being used in conventional medicine, the only patient who turned out to be incompatible was a body-builder. Heavy musculature prevented the LUCAS from functioning, but adipose tissue would conform with the shape of the LUCAS frame. A LUCAS document claims that the device can be used on patients weighing up to 350 lbs, and includes a photograph to prove it, shown in Figure 9-18. The document points out that that the LUCAS is designed to encircle the chest—not the belly, where more fat typically tends to accumulate. Literature from Michigan Instruments claims that their equipment will accommodate a patient weighing more than 600 lbs, but no photographic documentation has been provided.

The LUCAS 3, which is no longer being marketed as an active compression-decompression device, was not being used by any cryonics organization as of mid-2019.



*Figure 9-18. The LUCAS 3 being applied to a patient who is stated to weigh 350 lbs.*

## **Autopulse**

The Autopulse is an all-electric device consisting of a thick backboard containing batteries, motor, and electronics. The patient is strapped into place on the backboard, and a nylon belt is wrapped around the chest. The belt administers chest compressions as it is tightened and released by a motor-driven pulley in the backboard. The Autopulse is shown in Figure 9-19.

A sophisticated system of control electronics includes pressure sensors in the backboard to gauge the tension of the belt, and accelerometers that measure the rate of compressions. However, the Autopulse includes no

provision for ventilating the lungs, and is incompatible with an ice bath, because its motor, power supply, and electronics would be submerged under water.



*Figure 9-19. The Autopulse. Its chest compressions are administered by a wide nylon belt that slides through the wrapping visible in the photograph.*

Suspended Animation made two attempts to modify the Autopulse for use with an ice bath. Figure 9-20 shows a plan by Charles Platt in which the device would be turned upside down and supported on the side rails of an ice bath, with two aluminum struts extending downward and terminating in pulleys. The chest-compression belt would become a serpentine belt, wrapped around the pulleys and the patient. A prototype, shown in Figure 9-21, was constructed but never worked reliably, as the modifications caused the elaborate built-in system of fail-safe sensors to generate error messages.

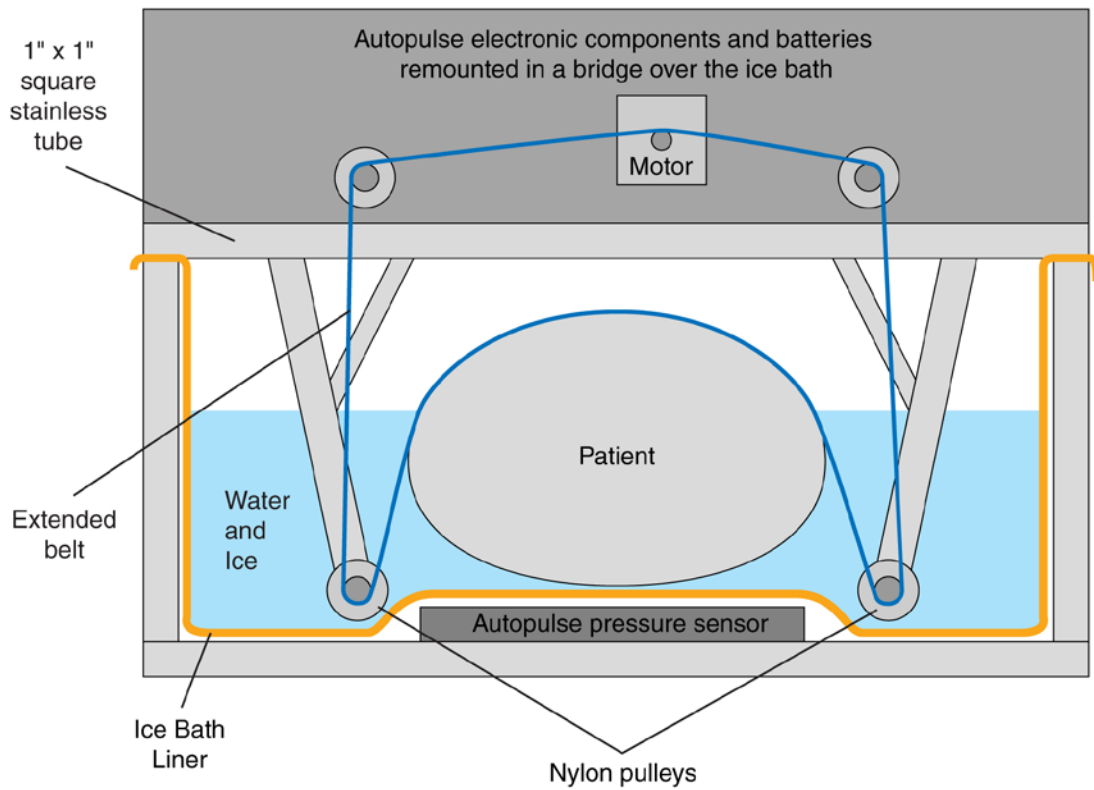

Figure 9-20. A plan for mating an Autopulse with an ice bath.



*Figure 9-21. A prototype built from the plan in Figure 9-20.*

Gary Battiato at Suspended Animation developed a different modification in which the Autopulse was placed under the ice-bath liner, and its chest-compression belt extended upward through two vinyl sleeves that were glued to the liner to prevent water from reaching the device. This design was used with mixed results.

Suspended Animation was still using an Autopulse during 2017. Based on field work that was done on cases shipped to Alcor, two employees at Alcor believe the Autopulse can inflict damage, such as broken ribs, when used on an elderly person for a long period of time. If the ribs perforate organs or vessels in the chest, this kind of damage will interfere with subsequent whole-body perfusion.

We are not aware of any study making a formal comparison between the force administered by LUCAS and Autopulse. Possibly either of the devices can cause significant damage during prolonged use. They were never really intended for the very long periods of compressions that may occur during transport of a patient in a cryonics case.

## **Cautions Regarding Mechanical Chest Compressions**

- Injury. Regardless of whether a chest-compression device is driven electrically or by compressed gas, it is sufficiently powerful to cause injury to the patient or even to the operator if used incorrectly.
- Small patients, including children, may be unsuitable. Using the Thumper, the operator has discretion to reduce the chest compression depth in ratio with the thinness of the body. Using the LUCAS, the system may refuse to enter the “pause” mode or “active” mode after the suction cup has been positioned. Three quick beeps indicate an error state.
- Large patients are unsuitable for the LUCAS if the frame of the device cannot be closed around the body without compressing the suction cup.



- Correct position on the chest is essential. Read instructions provided with the device, and do not proceed if you are uncertain. If a patient has any kind of lubricant on the chest (such as is used by ultrasound technicians), this must be removed to prevent the suction cup from sliding around.
- Chest fatigue occurs while any chest-compression device is running. The resilience of the chest gradually diminishes, so that it doesn't "bounce back." Consequently, compressions become less effective.

## **Other Mechanical Devices for CPS**

Three devices have been found that seem to have been developed to compete with Jolife and Michigan Instruments. They are summarized briefly below. As of mid-2019, none of them had been adopted or tested by a cryonics organization, and their relative advantages are unknown.

The **Brunswick Heartsaver** was demonstrated in 2016 at the EMS World Convention. YouTube videos are online, but the device may not have been marketed. It is driven by compressed gas and provides ventilation as well as chest compressions.

The **Lifeline Arm** was introduced by Defibtech, which already markets defibrillation products. It appears to be a copy of the LUCAS, at a lower price. The unit is battery-driven. It uses a pad to apply chest compressions, not a suction cup. See Figure 9-22.



*Figure 9-22. The Lifeline Arm appears to be a LUCAS imitation.*

---

The **Corpuls CPR** was developed by a German company that has been making defibrillators since 1982. Their web site provides no specifications, but the unit appears to be electrically powered. It uses a disc to apply chest compressions, not a suction cup. See Figure 9-23.



*Figure 9-23. The Corpuls CPR, developed in Germany.*

During 2006, at Suspended Animation in Florida, Charles Platt designed and fabricated a simple, unpowered device using two levers to reduce the strength needed for manual chest compressions. A prototype made from ABS plastic is shown in figure 9-24. It was never tested extensively, and was abandoned when company management was unwilling to finance further development.

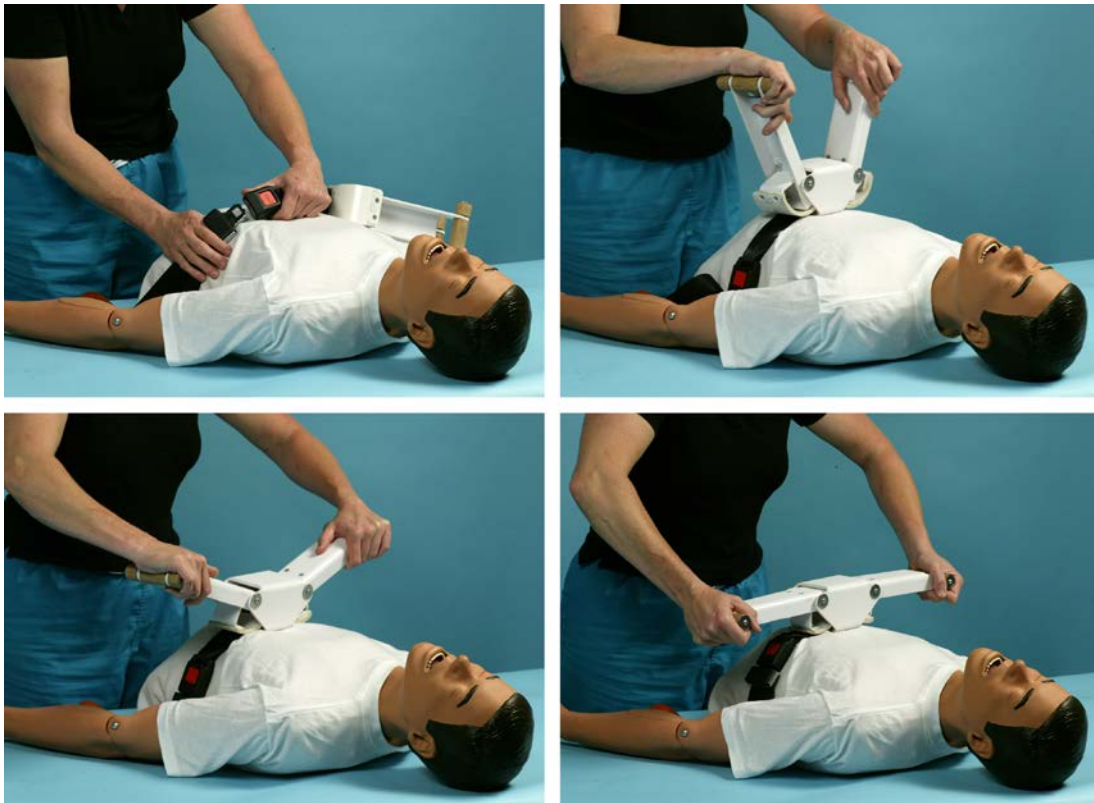

*Figure 9-24. This prototype of a device to reduce the strength needed for chest compressions was envisaged as being mass produced and commercially available for less than \$30. It could be kept in the homes of cryonics organization members and people with a high risk for cardiac arrest.*

## Sources

Information about specific products was derived from manufacturers' web sites.

PDFs of the following printed materials describing the history of chest compressions can be found online:

“Cardiac Massage: A Method Rescued from Oblivion” by Philippe Juvin and Jean Marie Desmonts. *Anesthesiology*, the Journal of the American Society of Anesthesiologists, Inc, September, 1998.

“The Introduction of Closed Chest Cardiac Massage” by Steven F. Bolling MD. *Annals of Thoracic Surgery*, 49:154-6, 1990.

## **10: Cardiopulmonary Support: Ventilation**

As discussed in Section 9, (mechanical) chest compressions can provide benefits, such as circulation of (neuroprotective) medications and enhanced cooling, without ventilating the patient. But the most fundamental objective of circulation is to oxygenate the blood to meet the metabolic demand of the human body. In theory, if compressions were adequate to meet the metabolic needs of the brain, there would be no need for other interventions to mitigate cerebral ischemia; but this situation rarely, if ever, occurs in cryonics.

Despite its obvious benefits, ventilation is among the most contested issues in human cryopreservation. To understand this controversy, picture the conditions under which cryonics patients are ventilated along a continuum. At one end is the ideal situation of cryonics as an elective medical procedure. The patient would be artificially ventilated while extracorporeal perfusion is used to lower body temperature until metabolic demands have diminished to a point where ventilation can be omitted without causing hypoxia. At the other end of the spectrum are cases where the patient has been in circulatory arrest for such a long time, starting ventilation would no longer confer any benefits.

What distinguishes these two polar opposite scenarios is that we do not require additional research to conclude that ventilation for a living patient is mandatory. If there is any research in this area to be done, it is to establish the optimal ventilation regime for such patients as they are cooled. Unfortunately, in patients who have suffered extensive periods of warm ischemia, there is no such obvious answer available. We cannot just argue that we should always ventilate because the patient will benefit if it works, and will not be worse off if it does not work. Under certain conditions, initiating ventilation can actually make things worse.

## Reperfusion Injury

During the last fifty years there has been increasing recognition in biomedical literature and clinical practice that simply restoring circulation and ventilation to a patient suffering from an ischemic insult (i.e., cardiac arrest or stroke) can have adverse effects on the outcome of the patient. The evidence for this perspective is corroborated in ultrastructural studies where organelles (such as mitochondria) that were subjected to transient ischemia (ischemia plus restoration of circulation) look worse than organelles where the ischemic insult is permanent.

There is an extensive literature about the biochemical mechanisms and pathophysiology of reperfusion injury which reflects a growing consensus that such reperfusion injury is multi-factorial in nature. Reperfusion injury is of great interest to the practice of cryonics because it can interfere with two important objectives of cryonics procedures: securing viability of the brain during stabilization procedures, and eliminating ice formation during long-term care. Reperfusion injury can interfere with both of these objectives by producing additional injury to the brain during cardiopulmonary support (and blood substitution) and contributing to perfusion impairment during cryoprotective perfusion.

In the context of ventilation there are two (proposed) mechanisms of reperfusion injury that matter: oxidative damage and apoptosis. Apoptosis is an energy-dependent form of cell death that may not be of great concern in cryonics because lowering the temperature of the patient, which defines the practice of cryonics, will inhibit the completion of apoptotic cell death. Of more concern is the potential for generating oxidative damage upon restoring circulation and ventilation.

To illustrate the challenge of making an informed decision about whether to ventilate a patient, consult the simplified graph in Figure 10-1. When ischemia is at zero, the benefit of ventilation is maximized with no reperfusion injury (there is no *re*-perfusion). When ischemic time is maximal there are no benefits to ventilation and only reperfusion injury. As is clear, there is a point where these two lines intersect; the benefits of ventilation are completely offset by the adverse effects of reperfusion injury.

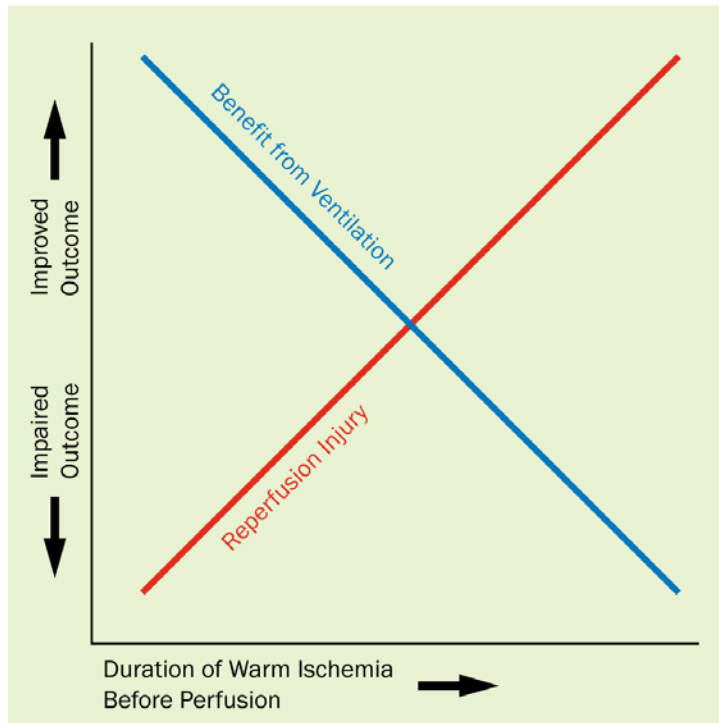

*Figure 10-1. The benefits of ventilation must be balanced against the penalties of reperfusion injury, which will increase with prior warm ischemic time.*

One of the simplifying assumptions in this figure is that it omits two of the defining elements of stabilization procedures: the administration of medications to mitigate reperfusion injury, and the induction of hypothermia. The existence of such interventions further complicates the question of when to omit ventilation during a cryonics case. In the absence of realistic cryonics research models that can capture these complexities, the existing biomedical literature is of little benefit in giving specific guidelines about ventilation in cryonics.

## **A Hard Criterion Against Ventilation**

In absence of detailed understanding of when the negative consequences of ventilation exceed the benefits, it would be reasonable to posit that there are no benefits to ventilation when mitochondria in the brain are so injured that

biological respiration has been irreversibly damaged. At that point, all one would do is to supply oxygen to generate oxidative damage without meeting the metabolic needs of the tissues. Such knowledge would at least be capable of putting an evidence-based categorical prohibition on ventilation of certain categories of cryonics patients.

The search for such a firm criterion may be more complicated than imagined because mitochondrial dysfunction is, not unlike many other biochemical processes in the body, a matter of degree. Experimental research into the effects of cerebral ischemia on mitochondria indeed indicates a time-dependent loss of function. Recent investigations reveal that ATP production is still possible in mitochondria isolated from human brains for up to 8.5 hours postmortem. What reduces the usefulness of such studies for making determinations about ventilating cryonics patients is that mitochondrial viability should be expected to correlate strongly with temperature, and the conditions under which these samples have been obtained and stored can greatly vary.

A further complication is that the ability of mitochondria to generate ATP is a necessary but not a sufficient criterion to endorse ventilation. If the overall state of cells is of such a nature that degradation will not be halted, there is still no benefit to supplying tissues with supplemental oxygen. In light of all these uncertainties, we cannot document an existing body of knowledge about reperfusion injury and ventilation in cryonics that allows for unambiguous recommendations. Since the stabilization medications that Alcor uses have been effective in recovering dogs from at least 15 minutes of warm ischemia without neurological deficits, ventilation should not be withheld from cryonics patients with less than 15 minutes of warm ischemia. It can also be argued that if ventilation is attempted after longer periods of warm ischemia that it should always be accompanied by rapid induction of hypothermia and administration of cerebroprotective medications to ensure the benefits of oxygenation while mitigating the potential adverse effects of ventilation.

Although the brain should be given priority in assessing the need for ventilation, it is also important to recognize that red blood cells have metabolic needs. When red blood cells run out of ATP they will become more



rigid and liable to block small vessels. Under such circumstances, the absence of ventilation will contribute to perfusion impairment during cryoprotective perfusion.

A final complicating factor is the role of ventilation in removing carbon dioxide. If carbon dioxide is allowed to accumulate, aerobic and then anaerobic metabolism will exhaust pH buffering capacity of the body. The resulting respiratory acidosis (low pH) is itself damaging to tissue.

## **Contra-Indications for Ventilation**

Despite our poor understanding of reperfusion injury in cryonics, there are a number of circumstances that constitute contra-indications for ventilation:

1. In the absence of qualified personnel, ventilation is contra-indicated because of the risk of poor placement of airways.
2. In the absence of a sufficient number of personnel and mechanical chest compression equipment, a standby team may be forced to alternate between chest compressions and ventilations. In such circumstances the patient will benefit more from uninterrupted vigorous chest compressions; such a protocol will still permit some degree of ventilation and will prevent cardiac output to decline over the course of CPS.
3. The presence of pulmonary edema. Pulmonary edema interferes with effective gas exchange and absent specific measurements to overcome the cause and/or symptoms of pulmonary edema, ventilation is contra-indicated.
4. A determination is made that the adverse effects of ventilation outweigh the benefits of ventilation. This is generally the case when Alcor expects ventilation to mainly contribute to oxygen-mediated vessel damage instead of meeting metabolic needs. There is at present no consensus about when this time is, except that it is likely measured in hours rather than minutes.

## **Anoxic CPS**

Because circulation expedites cooling and is necessary to circulate medications, there can be circumstances where it is preferable to restore circulation without exposing the patient to air or oxygen. Conducting anoxic CPS is not the same as eliminating ventilation because vigorous chest compressions are still effective in generating some degree of ventilation.

A further complication is added by the fact that, for most patients upon circulatory arrest, there is still a significant amount of oxygen in the large vessels. Upon restoration of circulation without ventilation such residual amounts of unutilized oxygen can still contribute to free radical damage. During reperfusion, high amounts of superoxide convert available nitric oxide to peroxynitrite—a highly damaging oxidant to (cerebral) vessels.

For rigorous anoxic CPS it may therefore not be sufficient to omit ventilation and other measures would have to be initiated such as occlusion of the airway or initial measures to desaturate residual oxygen in the vessels such as ventilation with an inert gas like nitrogen. Anoxic CPS may also require complimentary pharmacological interventions to mitigate the effects of anoxia such as metabolic imbalances and red cell aggregation and inflammatory vascular damage.

## **Airway Access Options**

After the patient has stopped breathing and is pronounced legally dead, stabilization procedures require prompt restoration of breathing using positive-pressure ventilation. There are a number of manual and mechanical techniques to accomplish this objective:

### *Mouth-to-Mouth Breathing*

Mouth-to-mouth (or mouth-to-nose) breathing is a common emergency ventilation technique for cases of sudden cardiac arrest or respiratory failure. This technique is not efficient and because of its associated fatigue and risk for transferring disease by direct contact with the patient's mucous membranes, this is not recommended for cryonics stabilization procedures. A

related technique is mouth-to-mask ventilation. Unlike mouth-to-mouth ventilation, this mode of manual ventilation does not require direct physical contact between the stabilization team member and the patient. Like mouth-to-mouth breathing, the use of this technique is not likely in cryonics because it is hard to perform on a moving patient during transport and if a team has access to a facemask it usually has access to a bag-valve-mask.

### *Bag-valve-mask*

The bag-valve-mask (BVM, also known as an “Ambu bag”) is the most common basic aid to perform positive-pressure ventilation in emergency medicine. The design of bag-valve-masks can vary. Some have a port for mechanical oxygen administration, but the most basic versions consist of a face mask that is pressed against the patient’s mouth to create a seal in conjunction with manual squeezing of the bag to ventilate the lungs, as shown in Figure 10-2. The bag and valve can also be used in combination with an airway such as an endotracheal tube or the Combitube.

In cryonics stabilization procedures, the BVM can be used to restore ventilation while the patient is prepared for lifting into the ice bath. It may also be a permanent means of ventilation when no equipment or expertise for mechanical/automated ventilation is present. Because the use of a bag and mask in absence of an airway can lead to gastric inflation (and associated vomiting and aspiration), the recommended protocol in cryonics is to place a (basic) airway. Placement of an airway also prevents breaking of the seal during ventilation, fatigue, and interruptions associated with transport-induced movement of the patient. It may also allow more ice to be placed around the patient’s head and face.



*Figure 10-2. A typical adult-size bag valve mask, by Lightning X EMS*

### *Endotracheal Tube*

Ventilation through a properly placed endotracheal tube, often referred to as an ET tube, is the “gold standard” for paramedics and anesthesiologists. Endotracheal intubation has been in common practice in cryonics and was the preferred method for facilitating ventilation in cryonics until the introduction of easier devices such as the Combitube and the King airway (see below). In emergency medicine, endotracheal intubation is classified as an advanced skill for paramedics, usually not permitted for EMTs. A basic ET tube is shown in Figure 10-3.

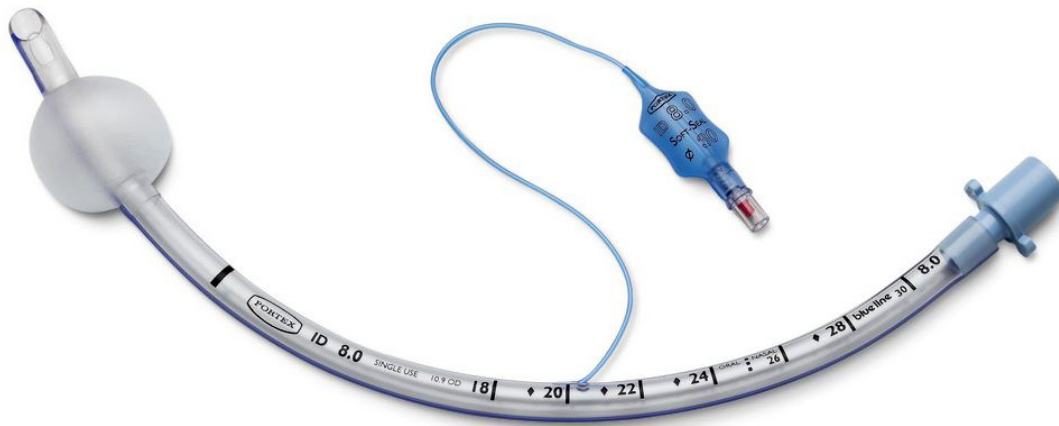

Figure 10-3. A typical endotracheal tube.

Endotracheal intubation presents a formidable challenge for non-skilled persons because it requires the placement of a tube directly into the trachea of a patient. Since the natural angle for placing a tube in the mouth of a supine patient is to place it in the esophagus (a feature that is exploited by easier equipment such as the Combitube) a laryngoscope is necessary to ensure that the tube is inserted through the vocal cords. Reportedly, in cryonics cases where there is a (lengthy) delay between cardiac arrest and placement of the endotracheal tube, the difficulty of this procedure increases.

If there are qualified medical professionals on the case, endotracheal intubation remains a valid means of establishing an airway for ventilation of the patient, although the availability of easier devices have made some cryonics organizations decide to stock standby kits without endotracheal intubation kits.

### *Tracheotomy*

A tracheotomy is an invasive surgical procedure in which an incision is made in the neck of a patient to insert an airway directly into the trachea. There are a number of variants of this procedure but due to its invasive nature it is uncommon in cryonics. At the time of writing, cryonics organizations no longer equip themselves to perform this procedure.

### *Combitube*

In the absence of exceptional emergency medicine skills for “blind” intubation, the natural angle is to place a tube in the esophagus. The Combitube is a device that takes advantage of this fact by utilizing esophageal placement to ventilate the patient. This feat is achieved by closing the distal end of the tube to re-direct room air or oxygen to the trachea and lungs of the patient. Distal and proximal balloons secure the tube in place. The dual-lumen tubing that defines the Combitube permits conventional ventilation in the rare case where the tube is placed in the trachea after all. A Combitube is shown in Figure 10-4.

Aside from its ease of use, one interesting feature of the Combitube is that it allows administration of fluids that into the stomach of the patient, such as Maalox, through the distal end of the tube. If this option is utilized, it is of the essence that placement of the tube in the trachea is ruled out to prevent introducing fluid into the lungs.

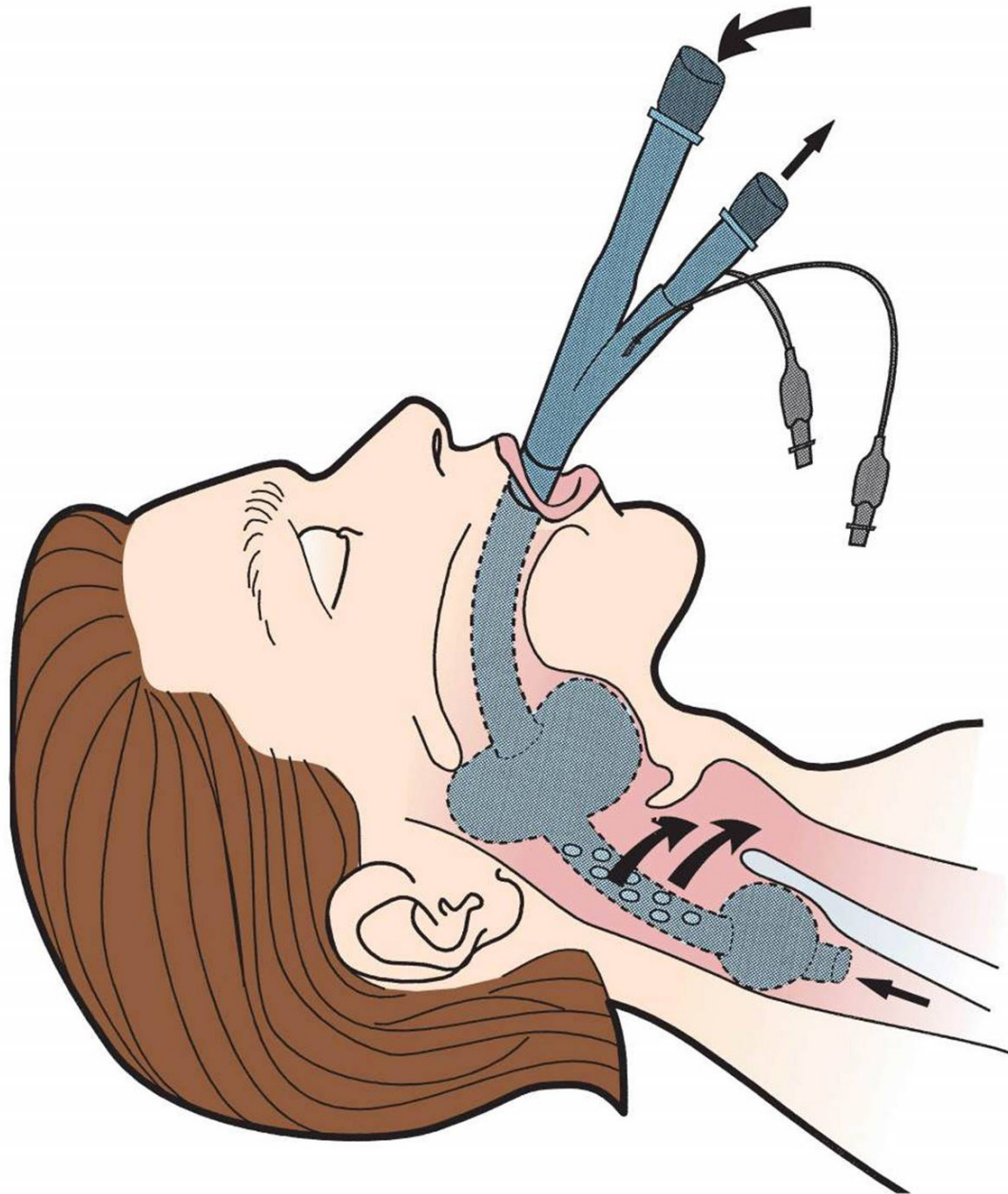

Figure 10-4. Placement of the dual-lumen Combitube. Note the perforations through which ventilation takes place while the tube is anchored in the esophagus. From *Trauma, seventh edition*, by Toschlog, Sagraves, and Rotondo.

The Combitube can be used for manual ventilation or mechanical ventilation. Its relative ease of use has led to its progressive replacement of the

endotracheal tube (or related airways) in cryonics since the mid-2000s. Prior to the introduction of the Combitube, the Esophageal Gastric Tube Airway (EGTA) had been included in standby kits and its placement was taught in cryonics transport courses. Like the Combitube, the EGTA prevents stomach contents from entering the trachea and the placement of the tube in the esophagus eliminates the need to visualize the vocal cords. The EGTA can also be used for administration of medications (such as Maalox) to the stomach. Unlike the Combitube and KING airway, the EGTA comes with a face mask with two ports for ventilation and stomach suctioning tubes. In contemporary emergency medicine, devices such as the Combitube have all but replaced the EGTA.

### *The King Airway*

This is another supraglottic airway device that delivers air/oxygen to the patient above the level of the vocal cords. Unlike the Combitube, the King airway is a single lumen device with a single inflation port that eliminates the learning curve associated with the dual-lumen method of the Combitube. The King airway comes in a number of versions, the preferred version for cryonics being model LTS-D which allows passing of a gastric tube through a second channel of the airway to administer Maalox. The King airway is available in a number of color-coded sizes for infant, child, and adult use.





*Figure 10-5. The King LTS-D Disposable Laryngeal Tube.*

### *Liquid Ventilation*

In liquid ventilation the lungs are directly oxygenated by cyclic introduction and withdrawal of an oxygen-carrier liquid, typically a perfluorocarbon. Liquid ventilation can be used to provide oxygen in situations where routine or emergency ventilation are not feasible or desirable, such as in cases of cardiac or lung trauma. In cryonics, liquid ventilation is envisioned as a means to rapidly cool the patient through the lungs without the necessity of surgical access. This concept is explored in Section 12.

Liquid ventilation (or cyclic lung lavage) can be achieved via a standard endotracheal tube.

### *Cardiopulmonary Bypass*

Emergency cardiopulmonary bypass can be used either during the initial stages of stabilization to restore circulation and oxygen or at a later stage of stabilization as means to internally cool the patient. Since putting a patient on cardiopulmonary bypass requires invasive surgery and cannulation (such as femoral-femoral cannulation), it cannot be considered a substitute for other means of restoring oxygen. Even if rapid emergency surgery is performed to

put the patient on bypass within minutes it is still necessary to ensure adequate circulation and ventilation before the procedure can be started.

Since cardiopulmonary bypass is mainly used as means to substitute an organ preservation solution for the blood, and to expedite cooling, it has been invariable practiced as strategy for blood washout and inducing hypothermia prior to shipping. As a matter of fact, with the exception of a small number of cryonics cases (brief review below) that involved the participation of cardiothoracic surgeon Jerry Leaf and cryonics researcher Michael Darwin, oxygenation during cardiopulmonary bypass in cryonics has been all but abandoned.

In ideal cases, it could be beneficial to continue oxygenation during cryoprotective perfusion, but cryonics cases in which this approach was pursued are even rarer than cases with cardiopulmonary bypass where oxygen was introduced during the procedure.

Cardiopulmonary bypass as a means of meeting oxygen demand stands apart from all other means of ventilation (including liquid breathing technologies) in that it does not require access to the patient's airway (although it could be combined with conventional ventilation). Oxygenation during cardiopulmonary bypass does not tie a cryonics team to a specific surgical protocol provided that the site chosen for cannulation allows for meeting the oxygen demands of the body. In practice, cryonics organizations prefer not to use the aorta (median sternotomy) in the field because it requires more skill than alternatives such as femoral-femoral bypass and it ensures that the heart and associated vessels are not damaged prior to cryoprotective perfusion.

## **Methods of Ventilation**

In cryonics there are four distinct modes of providing oxygen or air to the patient: manually, mechanically (automated), cardiopulmonary bypass, and through oxygen-carrying solutions (which can be conducted in a manual or automated fashion). One of the great challenges of ventilation is to determine the right volume, frequencies, and pressures in the absence of physiological breathing. In ideal circumstances, blood gases and expired air would be

continuously monitored to match oxygen demand and oxygen needs. In a typical cryonics case, team members usually have to rely on emergency ventilation conventions and occasional feedback such as oxygen saturation and end-tidal CO<sub>2</sub> measurements.

The most common method of ventilating the cryonics patient in recent years involved the use of a bag-valve mask, either through securing the mask or through connecting the bag to an airway like the endotracheal tube or Combitube. The typical bag has a volume of approximately 1600 ml of air. Two hands should be used to completely squeeze the bag – observe chest rise and repeat after 5 seconds.

Some mechanical cardiopulmonary support devices support automated ventilation, as described in Section 9. Unlike manual bag-valve ventilation in which the patient is ventilated by room air, such devices can introduce 100% oxygen, if that is being used to power the piston of the device. Of the three major mechanical CPS devices that are used in cryonics—the Michigan Instruments Thumper, the LUCAS, and the AutoPulse—only the Thumper has a built-in ventilator.

With the rise in popularity of mechanical CPR devices without an integrated ventilator there has been an increased need in cryonics to identify affordable stand-alone mechanical ventilators. This need has not been met in many cases, but there have been a number of exceptions in recent years.

The Surevent SV2 is a unique device which does not require electrical power but does use a source of pressurized oxygen. It consists of a pressure regulator which delivers cycles of oxygen from a source of up to 50psi. It is light and easy to set up, is only a fraction of the cost of hospital mechanical ventilators, and ventilates until a specific pressure is reached, the peak inspiratory value being 20cm H<sub>2</sub>O (although this can be adjusted). Flow rates range from 10 to 40 liters per minute. The ventilation rate can be set based on chest rise or ETCO<sub>2</sub> readings. One interesting feature is that the surevent allows for integrated PEEP. A battery-powered manometer is included in the SV2+. See Figure 10-6.

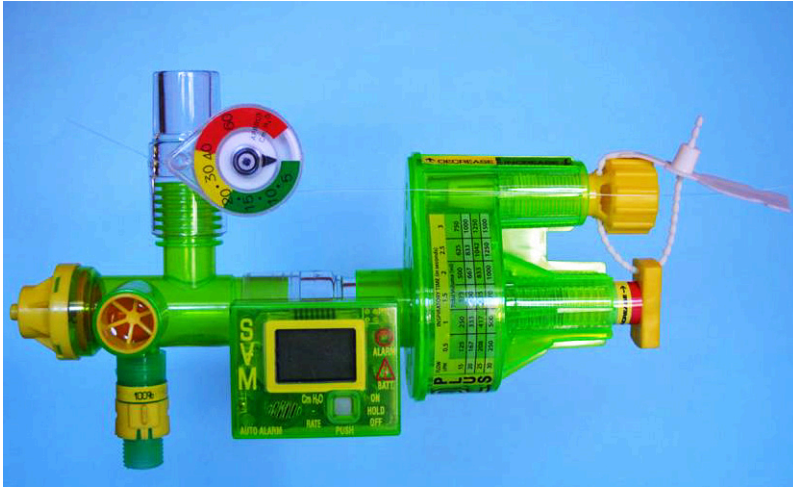

*Figure 10-6. The Surevent SV2 attaches to an oxygen source and delivers metered inspirations to the patient. The SV2+ includes a battery-powered manometer, shown in this photograph.*

## **Pulmonary Edema**

One of the most notable problems in cryonics is the presence of pulmonary edema. This can be present prior to pronouncement of legal death as a consequence of terminal illness or acute insult, but is also a typical consequence from prolonged (mechanical) chest compressions. Pulmonary edema is also often associated with blood washout and cryoprotective perfusion, in particular under conditions of prolonged circulatory or respiratory arrest.

The most basic treatment for pulmonary edema is to supply oxygen. Other conventional treatments include PEEP, medications to reduce preload and afterload, suctioning, and diuretics that remove fluid from the circulatory system.

The most practical treatment in cryonics is negative pressure drainage of fluid from the lungs. Although Alcor standby kits have usually included inexpensive manual suction devices, the consensus among experienced cryonics practitioners has been to recommend more powerful portable machines such as the one displayed in Figure 10-7.



Figure 10-7. A Laerdal suction unit. It allows the option of battery power.

Another powerful treatment for pulmonary edema is liquid ventilation. Although the concept was not developed in cryonics with the intention of treating pulmonary disorders, it can remove fluids from the lungs by exploiting the fact that perfluorocarbons are heavier than water. As the perfluorocarbon liquid descends to the bottom of the lungs, water-based fluid rises above it and can be suctioned out.

## Hypothermia and Oxygen Requirements

As the brain temperature of the patient decreases, so will oxygen demand. As a rule of thumb, a decrease of 10 degrees C in temperature will reduce cerebral

oxygen demand by 50%. A further drop of 10 degrees will reduce oxygen demand by a further 50%, and so on. This rule allows a cryonics stabilization team to interrupt chest compressions and ventilations at a temperature of approximately 20 degrees C to perform surgery and prepare the patient for remote blood washout or cryoprotective perfusion procedures.

In theory, as the temperature decreases, ventilation frequency should also decrease proportionately with decreased oxygen demand. In practice, such a linear protocol is hard to achieve using manual ventilation or the ventilation function on the Thumper. A more practical protocol would be to reduce ventilations by 50% when a temperature of 27 degrees C is reached. Oxygen saturation measurements and end-tidal CO<sub>2</sub> measurements can be used to time and review changes in ventilation.

## **Ventilation Adjuncts**

There are a number of ventilation adjuncts to improve emergency ventilation or to deal with specific pathophysiological circumstances. In this chapter I will briefly review the use of the ResQPOD and PEEP.

The ResQPOD is an Inspiratory Impedance Threshold Device that is used in conjunction with chest compressions to improve cardiac output. While the aim of this adjunct is to improve blood flow its mechanism of action is to prevent positive-pressure ventilation during the decompression phase of chest compressions.

PEEP stands for positive end-expiratory pressure. This is the pressure in the lungs above atmospheric pressure that exists at the end of expiration. PEEP can be used to keep the lungs inflated and decrease intra-alveolar water accumulation (edema) during CPS. Although PEEP valves and bag-valve masks with PEEP have been included in cryonics standby kits, there is no documented history of deliberate use of PEEP in cryonics.

## **Monitoring Ventilation**

A detailed review of monitoring options is provided in Section 14, but a brief review is included below.

**Observation:** Signs of good ventilation include breathing sounds, consistent chest expansion, and change of skin color (in the case of prior hypoxia, skin color should change from blue to pink).

**Pulse Oximetry:** Pulse oximeters can be attached to a finger (or ear lobe) to monitor pulse rate and oxygen saturation levels and are usually included in the standby kits of cryonics organizations for monitoring the patient prior to pronouncement. Its use during CPR is controversial because of the lack of a good signal and erratic readings. This situation may be aggravated in cryonics as a result of aggressive vasopressor use, hypothermia, and splashing of water. But bearing in mind the ease of taking pulse oximetry readings, pulse oximetry may be worthwhile when looking for trends.

**End-Tidal CO<sub>2</sub>:** A good, and non-invasive indicator of cardiac output and oxygenation during CPS is end-tidal CO<sub>2</sub>. This is the partial pressure of carbon dioxide (CO<sub>2</sub>) at the end of an exhaled breath. In emergency medicine, disposable colorimetric ETCO<sub>2</sub> detectors are often used. More recently, compact numeric field capnometers have become available such as the Capnocheck. Normal ETCO<sub>2</sub> levels are between 35 and 45 mmHg. End-tidal CO<sub>2</sub> readings can also be used to validate proper endotracheal intubation. In the case of poor placement (in the esophagus), readings will be low or negligible.

## Case Report Examples

Although ventilation and oxygenation of patients has been a standard procedure in the history of cryonics, cases in which ventilation procedures were described in detail and analyzed have been relatively rare. The following table identifies cryonics cases where ventilation and oxygenation were carried out in other procedures than CPS (as documented in the report) and where other ventilation/oxygenation challenges are described in some detail.

A-1068 (1985)	CPB oxygenation, CPA oxygenation, and blood gas analysis
A-1133 (1987)	Pulmonary edema, suctioning, CPB oxygenation, CPA oxygenation, and blood gas analysis
A-1165 (1988)	CPB oxygenation

A-1036 (1988)	CPB oxygenation
A-1169 (1998)	Blood gas analysis
A-1049 (1990)	ETCO2 monitoring, CPB oxygenation, <i>Nitrogen</i> CPA perfusion, and blood gas analysis
A-1312 (1991)	ETCO2 monitoring
A-1260 (1992)	ETCO2 monitoring, discussion of airways and suctioning, and (low flow) CPB oxygenation
A-1184 (1992)	Pulmonary edema
A-1871 (1995)	Pulse oximetry, ETCO2 monitoring, CPA oxygenation, and blood gas analysis
A-1110 (1997)	Blood gas analysis
A-1876 (2002)	Pulmonary edema, ETCO2 monitoring, perfluorocarbon cooling
A-2020 (2003)	Pulse oximetry
A-2024 (2005)	ETCO2 monitoring, administration of medications through endotracheal tube
A-2071 (2005)	CO2SMO (Capnograph/Pulse Oximeter)
	CO2SMO and SUREVENT Emergency Transport Ventilator
A-2420 (2009)	Mechanical ventilator, ETCO2 monitoring, and blood gas analysis
A-1556 (2010)	CO2SMO for patient assessment

As can be seen from this table, the practice of CPB oxygenation and CPA perfusion oxygenation have been abandoned since the early 1990s with only one case of CPB oxygenation in 1995, executed by BioPreservation, Inc. under contract with CryoCare Foundation. As a general rule, oxygenation of the patient since that period has been confined to ventilation during cardiopulmonary support.

Blood gas analysis has also been all but abandoned with only a recent exception in a recent (2009) case performed by Suspended Animation under contract with Alcor.

The 2000s continued to see occasional cases with end-tidal CO<sub>2</sub> monitoring and the use of more sophisticated capnography equipment such as the CO<sub>2</sub>SMO. Since mechanical CPR devices such as the Lucas and the Autopulse do not support ventilation, a number of cases have seen the use of automated emergency ventilators. One Alcor case, A-1049 in 1990, shows the addition of nitrogen to the perfusion circuit during cryoprotectant perfusion to



protect the patient against oxygen-induced reperfusion injury. To our knowledge, such a protocol has never been repeated in cryonics.

## 11. Induction of Hypothermia

Human metabolism is supported by biochemical processes that require a minimum temperature to function normally. When body temperature falls below that level, the person enters a state of hypothermia. If the temperature continues to fall, neurons in the brain will be unable to maintain their function and the person will eventually lose consciousness.

The following classifications of body temperature correspond with terminology often used in experimental and clinical literature:

- Mild hypothermia: 32-36 degrees Celsius
- Moderate hypothermia: 28-32 degrees Celsius
- Deep hypothermia: 18-28 degrees Celsius
- Profound hypothermia: 5-18 degrees Celsius
- Ultra profound hypothermia: 0-5 degrees Celsius

While hypothermia is hazardous and potentially fatal to human beings, during cardiac arrest it can provide a therapeutic benefit. When the heart stops beating, lack of blood flow deprives cells of oxygen and glucose, leading to a toxic cascade of reactions that can ultimately result in destruction of the cell. Metabolism now becomes a life-threatening process instead of a life-sustaining process, and hypothermia can delay cellular injury by slowing the metabolic rate.

For this reason, when a standby team intervenes following legal death, the first priority is to cool the patient. *Unlike some other stabilization procedures, induction of hypothermia is not optional.* The primary goal of a standby team, after death is pronounced, is to reduce the patient's temperature as quickly as possible to a theoretical optimum approaching 0 degrees C.

Care must be taken not to go below that temperature until the patient has received cryoprotection, as ice formation will cause serious injury.

Figure 11-1 shows a comparison between different methods of cooling during an Alcor case. Surface cooling is much less effective than intravenous cooling, but it is still very important, especially because it can begin immediately and requires no surgical skills. Intravenous cooling, which typically occurs during blood washout, will be discussed in detail in Section 16.

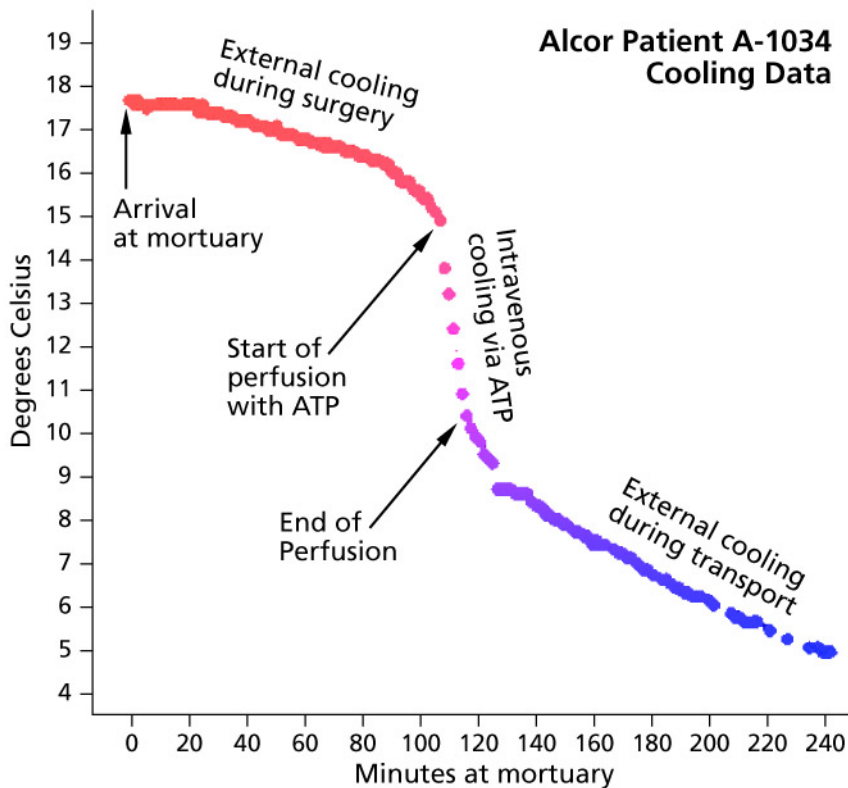

Figure 11-1. External cooling vs. intravenous cooling during an Alcor case. ATP refers to the Alcor Transportable Perfusion equipment that was used for many cases in the 1990s through 2000s.

## The Physics of Cooling

To cool a patient effectively, team members must understand what cooling really means. When we “make something cold,” what we are really doing is creating pathways for heat to flow out of the object.

If the object is warmer than its environment, heat from the object will tend to flow into the environment. The object will become cooler and the environment will become warmer until they reach thermal equilibrium. Heat always tends to flow from a warmer place to a cooler place, just as water tends to flow from a higher place to a lower place.

The flow of heat can occur in three ways:

- Convection (heat is picked up by a circulating gas or liquid)
- Conduction (heat travels through a solid object or liquid)
- Radiation (heat radiates from a warm object into its surroundings)

Imagine a patient resting on a bed in a room where the air temperature is 20 degrees Celsius. The patient's body temperature is 36 degrees, so heat will be transferred from the patient into the room. Currents of air will take some heat away through convection, and the patient's skin will lose some heat by radiation. Additional heat will be lost by conduction into the mattress of the bed, although this will not be very efficient, since a mattress is not a good thermal conductor.

All of the processes in this scenario will be relatively slow. Thus if a patient dies unexpectedly and remains undiscovered without intervention, the toxic cascade of harmful reactions in the brain will proceed in the absence of significant hypothermia, and will do a lot of damage.

A simple way to intervene is by immersing the body in very cold water. The patient will now cool faster, because

- The temperature difference between the body and the water is greater than the temperature difference was between the body and the air.
- Water conducts heat faster than air, by thermal conductivity.
- Water can also absorb more heat with less temperature rise, as it has greater heat capacity.

In fact, the ideal scenario for external cooling would be to arrange that every square inch of a patient's skin is chilled with water at a fraction above 0 degrees Celsius.

As heat in the patient's body is conducted into the water, the water will become warmer, especially in areas close to the skin. We can improve cooling by circulating the water with a pump, so that the warm boundary layer around the patient is disrupted and replaced with colder water.

We can also add ice. *As ice melts, it absorbs heat without increasing its temperature.* The heat that ice absorbs, known as the latent heat of fusion, loosens the atomic bonds that maintain its crystalline structure. Melting 1 gram of ice requires 80 times as much heat as raising the temperature of 1 gram of water by 1 degree Celsius.

A mixture of ice and water is ideal for a cryonics patient as it automatically maintains a temperature slightly above 0 degrees Celsius until all the ice has gone, and provides the fastest method of external cooling that is also consistent with safety. The patient cannot freeze, because the melting ice cannot make the patient colder than itself.

Note that the core of the patient will still contain heat, and this heat must travel outward through the patient's brain and body to the skin before it can be taken away. In fact the thermal conductivity of a person puts a limit on the effectiveness of external cooling, and a larger patient will take much longer to cool than a smaller one.

In some cases, the cooling process has been accelerated by introducing cold liquids inside the body. Internal cooling is more efficient than external cooling (as shown in Figure 11-1) because it reduces the distance that heat in the core of the body must travel to reach the cooling agent. On the other hand, all methods of internal cooling require some preparation or medical skill, while external cooling can be applied almost immediately by people with minimal training.

## **Deploying an Ice Bath**

Ice and ice-cold water are usually administered by immersing the cryonics patient in a portable ice bath while using a pump to recirculate ice-cold water

over exposed skin areas through perforated tubes. The portable ice bath is often referred to as a PIB, and the surface-cooling device may be referred to as an SCCD (Surface Convection Cooling Device) or, more often, a “squid.” Additionally, a helmet or face mask may be used with the SCCD to apply water to the head and face of the patient through perforations.

Figure 11-2 shows a mannikin that has been placed in an ice bath for training and demonstration purposes. The ice bath has a steel frame with a gray vinyl watertight liner. A battery-powered LUCAS device has been installed to apply chest compressions, the small gray box at right is an air compressor ventilating the patient, and the black helmet is cooling the head via recirculated ice water.



*Figure 11-2. A mannikin in an ice bath at Alcor Foundation.*

Many ice-bath designs are illustrated at the end of this section, all sharing the same design goal: to enable a patient to be cooled with at least 40 kg ice (about 100 lbs) and 20 liters of water (about 5 gallons) while cardiopulmonary support circulates blood and ventilates the lungs, and medications are administered. (Sections 9 and 10 have explained cardiopulmonary support. Section 13 will discuss medications.)

Some ice baths have been designed to collapse into a package that can be transported as baggage on an airline; others are noncollapsible, for deployment in a ground vehicle. Some have legs, for easier access to the patient; some rest at floor level, and can be transported in a vehicle where there is limited head room.

At the beginning of a standby, an ice bath should be placed as near to the patient as circumstances permit. This may require diplomatic negotiation with medical staff or relatives. Once the team has received permission for deployment, they must assess the area carefully to make sure that the ice bath can be removed when the patient has been moved into it with water, ice, and equipment. Stairs should be avoided, as they will require tipping the ice bath, which can release a flood of water. Elevators must be able to accept the full length of the bath, and it may have to negotiate corners in hallways. A few ice-bath designs have telescopic or hinged end sections that can reduce the length of the bath temporarily to make it more maneuverable.

A fully loaded ice bath generally requires at least three people to move it safely, especially if it must be lifted over steps or a curb.

After the ice bath has been placed near the patient, ice should be kept nearby in insulated picnic chests. Some melting is acceptable, but during a protracted standby an accumulation of water should be drained from each picnic chest and the ice should be refreshed once each day. As much as one-quarter of the ice will melt inside a picnic chest during each 24-hour period, if the chest is in a warm environment.

## **Using the Ice Bath**

Any clothing on the patient should be removed after pronouncement, as it will inhibit cooling and may interfere with other procedures. If a lifting sling is available to facilitate transfer, the patient should be rolled onto one side, the sling should be spread out on the bed, and the patient is then rolled back onto the sling.

The patient will be most easily moved if the ice bath can be positioned end-to-end with the bed (not alongside the bed), and team members can line up on each side to raise the lifting sling.

An ice bath containing a lifting sling is shown in Figure 11-3.



*Figure 11-3. A lifting sling fabricated from nylon webbing and netting is shown in an ice bath at Suspended Animation, Inc.*

Do not place any ice in the ice bath before moving the patient. You do not want ice under the patient during cardiopulmonary support.

As soon as the patient is in the ice bath, all available ice should be added, together with approximately 5 gallons of water, which should be sufficient to cover the base of the submersible pump that supplies the SCCD (assuming the ice bath is on a level surface).

Ice should be placed around the patient's head first, but be careful not to allow ice or ice-cold water to interfere with temperature readings from thermocouple probes that are inserted into the ears or nostrils.

Ice in bags is "less messy" than loose ice, but will not cool as effectively. Air pockets tend to exist inside the bags, and will act as an insulator. Also, water tends to gather inside the bags, and since the water will remain there without circulating, it too will slow the cooling process.



Bagged ice is necessary for packing patients when they are prepared for shipping, to reduce the risk of water leaking from a shipping container. But bagged ice is not appropriate for initial cooling.

Cover the patient as thoroughly as possible. When in doubt, add more ice! Shaved or crushed ice may cool more effectively than cubed ice, but is not so widely available. Regardless of the form of ice that it used, team members should break up any large chunks before adding them to the ice bath. The contents of ice bags can be broken up by banging the bags against the floor before opening them.

As soon as the ice has been added, the SCCD tubing should be distributed over the exposed (upper) skin surfaces with a preference for head, neck, axilla, and groin. The submersible pump that supplies ice-cold water through the tubing should be placed under water at the foot of the ice bath, and should be switched on. Figure 11-4 shows a battery-powered SCCD kit that was developed at Suspended Animation, using sections of perforated tubing that are color coded to aid in plugging them together.

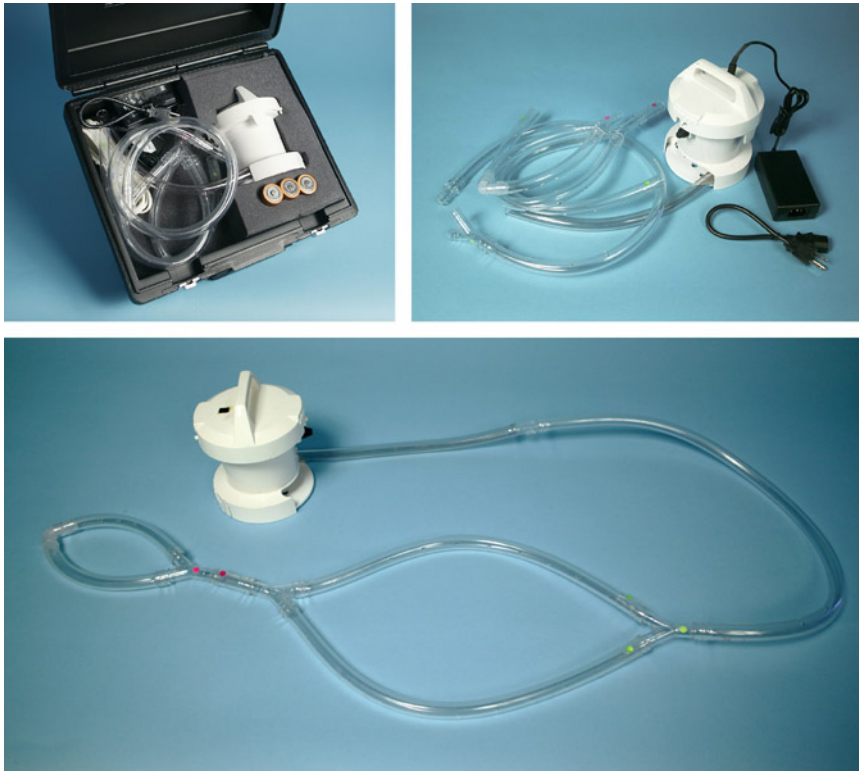

*Figure 11-4. An SCCD device consisting of sections of perforated tubing that are supplied by a submersible pump. Although the pump is battery-powered, a socket for an external power supply has been added. The loops in the tubing are for the patient's head and chest, the larger loop fitting around the plunger on a chest-compression device.*

A recent design of face mask is shown in Figure 11-5. It is a hollow shell with perforations in the interior surface.



*Figure 11-5. A mask to promote cooling of the head. Water is introduced in the threaded bushing and is released via perforations underneath the mask.*

The relative efficiency of different methods of external cooling is illustrated in Figure 11-6, which shows cooling curves for three Alcor patients. Patient A-1133 weighed 56.8 kg, patient A-1169 weighed 57.3 kg, and patient A-1049 weighed 36.4 kg. A smaller patient will naturally tend to cool faster than a larger patient, but still the use of an SCCD appears to have made a positive difference.

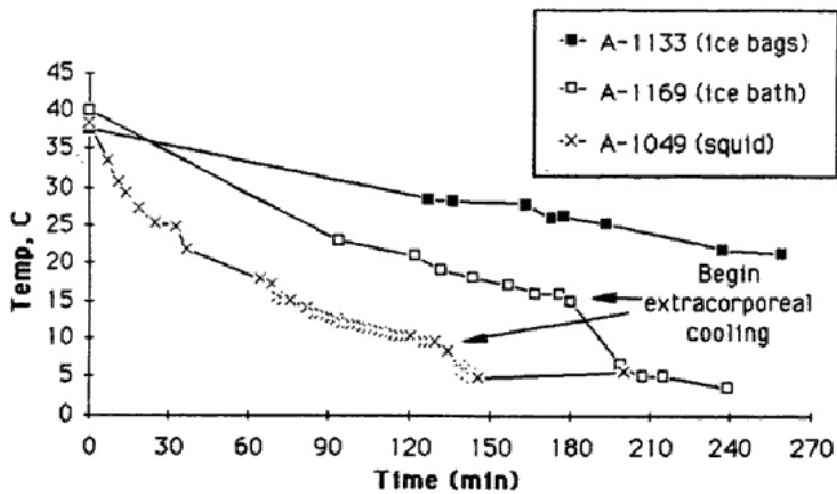

Figure 11-6. Comparison of cooling methods..

Chest compressions also accelerate the cooling rate, by circulating warm blood from the core of the patient to the capillaries near the skin where heat will be removed. Chest compressions should usually continue actively while external cooling is being applied.

## Improvised External Cooling

If an ice bath cannot be used or is unavailable, team members may improvise a substitute by placing the patient inside a body bag (if one is available) before adding ice and water. Note that the bag will become difficult to move after large amounts of ice and water are added.

Body bags come in different weights, depending on their purpose. Lightweight bags are often found in mortuaries, and are not designed to hold heavy weights of ice and water in addition to the patient. However, this type of bag may be usable if it rests on a lifting sling.

If no body bag is available, the patient may rest on any hard, level surface, and under these circumstances ice may be applied in ziploc bags. Once again, cover the head first followed by areas where large vessels are close to the surface, such as the anterior neck, the axilla, and the groin. If only a limited quantity of ice is available, it should be applied to the head. Be sure

to shift and turn the ziploc bags frequently, to maximize contact with unmelted ice.

To avoid the drawbacks of bagged ice, the patient's head can be immersed in a basin with water ice. Such a device can be made by cutting a neck-size groove in a picnic chest.

A major disadvantage of cooling only the head is that if chest compressions are applied, cooled blood will circulate from the brain down to the body, and warm blood from the body will circulate up to the brain. Since the need for chest compressions may vary depending on factors such as the patient's medical history, the availability of medications, and the time that has elapsed since pronouncement, the team should consult a medical advisor before reaching a decision regarding chest compressions when insufficient ice is available to cool the whole body.

Inducing even a relatively small drop in temperature (around 2 or 3 degrees Celsius) is worthwhile. This means that if a standby team is not present, a patient may still benefit if relatives or friends pack the head and, ideally, also the body in ice. Unlike other stabilization procedures, external cooling with water ice entails little risk of error—provided, of course, no one should attempt to intervene until after the patient has been pronounced.

Remember that while hypothermia is very desirable after pronouncement, it is dangerous to anyone who is still alive.

## **Internal Cooling**

Methods of internal cooling include:

- Chilling large-volume medications before they are infused.
- Infusing chilled saline solution or ice slurry into the circulatory system.
- Gastric, colonal, or peritoneal lavage.
- Ventilating the lungs with a chilled breathable liquid (“liquid ventilation”).

- Placing the patient on extracorporeal bypass and passing the blood (or a blood substitute) through a heat exchanger before it recirculates throughout the patient.

### *Chilled Medications*

Unless this cooling method is complemented with others, the temperature drop that can be achieved is minimal.

Note that mannitol, which is used to prevent and reverse swelling of the brain and to protect brain cells from harmful free radicals, should not be cooled below room temperature as this will result in the formation of crystals. This is discussed in Section 13.

### *Infusions*

Suppose we make a gross approximation, assuming that the patient possesses about the same specific heat as a saline solution (i.e. they both require the same amount of heat to increase their temperature by the same amount). Suppose we infuse 1 liter of fluid, weighing approximately 1 kg, into a patient weighing 70 kg with a body temperature of 36 degrees. In this example, a drop in temperature of 0.5 degrees in the patient will be sufficient to raise the temperature of the infused liquid by about 35 degrees. Therefore, even if a saline infusion is near 0 degrees Celsius and the patient is near normal body temperature, and even if the saline is circulated uniformly throughout the body, the most we can expect to achieve, from a one-liter infusion, is to cool the patient by half a degree.

If an ice slurry is used it will be much more effective, because the ice will absorb latent heat in the process of melting. However, the salinity of the slurry must be comparable to that of the body (i.e. pH and osmolality must be comparable). If pure water is introduced to the veins of the patient, the result will be edema—swelling of organs such as the lungs and the brain, and bursting of the cells

Ice slurries have not been used in any cryonics case at the time of writing.

Care should be taken to insure that the patient is not overloaded with fluids. The human body can accommodate some variations in fluid-to-mass

ratio without harm, but the team leader should consult the cryonics organization's medical advisor before attempting intravenous saline infusions.

### Lavage

Derived from the French word for "washing," the term "lavage" is used in medicine to describe introducing a cold fluid into an organ of the patient. In gastric lavage, fluid is introduced to the gastrointestinal system; in colonic lavage, the colon is used; and in peritoneal lavage, fluid is introduced under the lining of the abdominal cavity. In a landmark CryoCare case in 1995, peritoneal and colonic lavages were used in conjunction with circulating ice-cold water to achieve unprecedented cooling rates. This is illustrated in Figure 11-7.

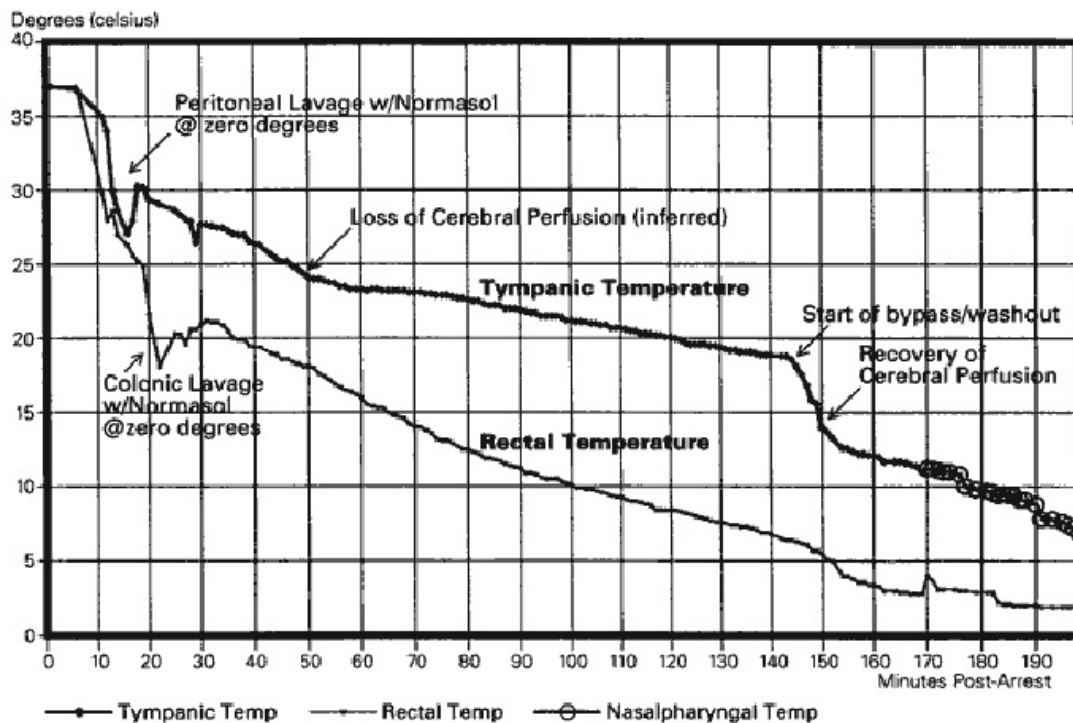

Figure 11-7. The effects of multiple cooling strategies on a CryoCare patient under the care of Biopreservation, Inc.

Lavage procedures should not be attempted by most team members because they require invasive techniques such as gastric intubation or surgery.

For example, during peritoneal lavage, a catheter is used to introduce a chilled solution to the peritoneal cavity through a small incision below the umbilicus. In gastric lavage, a gastric tube is used to introduce a chilled fluid to the stomach of the patient.

### *Liquid Ventilation*

A special case of lavage is the infusion of a chilled breathable liquid into the lungs. Although commonly referred to as liquid ventilation, this procedure may or may not include oxygen dissolved into the liquid that enters the lungs.

See Section 12 for a detailed presentation on liquid ventilation.

### *Extracorporeal Bypass*

In conventional medicine, during operations such as heart surgery where the patient must enter a state of cardiac arrest, a surgeon accesses the circulatory system so that blood can be piped through an external pump before being returned to the body. This procedure is known as extracorporeal bypass, and is often referred to as “placing the patient on bypass.” The process of introducing liquid into the circulatory system is known as perfusion, and the person who runs the bypass equipment is a perfusionist.

Since the blood can pass through a heat exchanger in addition to the pump, bypass is a very efficient way to reduce the temperature of a patient. In fact, it can achieve faster cooling rates than any other method. In a cryonics case, bypass is also used to substitute an organ preservation solution or, if neuro-vitrification is the chosen strategy, a vitrification solution.

Typically in a whole-body cryonics case, access is obtained via femoral vessels in the upper thigh. Raising and cannulating these vessels requires surgical skill and may take half an hour or more, during which external cooling should continue. Almost always, the patient will be moved from a hospital, hospice, or home setting to a suitable location where surgery can be performed, such as the prep room of a mortuary or a specially equipped vehicle. For these reasons, other cooling interventions should be used initially, and bypass should be reserved as the last step before transport of the patient to the cryonics organization.

If neuro-vitrification is done, access is via the carotids.



## **Other Methods of Cooling**

Just as ice absorbs heat in the process of melting, water absorbs heat in the process of evaporation. In fact, the quantity of heat that will change a liter of water into vapor is about seven times the quantity required to melt a kilogram of ice. In military medicine, patients suffering heat stroke have been cooled by spraying them with water which is then evaporated by fans or helicopter rotors. However, body temperature and ambient temperature must be high for this procedure to be effective, and it is generally not practical in cryonics applications.

Non-invasive brain cooling techniques include cooling through the sinus cavity. Although these techniques could slightly increase the cooling rate of the patient, the practice of placing the patient in circulating ice water and surrounding the head with ice should incorporate most of the benefits of such cooling methods.

One approach that is gaining in popularity in contemporary medicine is the use of endovascular cooling, in which the temperature of a patient is dropped by directly cooling the blood through an endovascular catheter. Instead of circulating the blood outside of the body (as in extracorporeal cooling), a catheter with circulating coolant (cooled saline) is placed into the patient's blood stream through central venous access. The efficiency of such endovascular cooling catheters can be increased by careful attention to design, materials and operating principles. For example, heat exchange can be increased by circulating the coolant countercurrent to the flow of blood. Despite the encouraging advances of these technologies for the induction of hypothermia in a clinical setting, these technologies are not practical during cryonics stabilization because they invariably come with a bulky control and heat exchange unit.

## **Temperature Measurement**

Measuring and recording temperatures during stabilization procedures is important, because the rate of cooling is an excellent indicator of success in protecting the brain from injury. It also yields data that we can use to compare the effectiveness of different cooling techniques in different cases.

The skin temperature of the patient is of little interest, since the skin should be covered in ice or ice-cold water and therefore should be near 0 degrees Celsius. Our primary concern is the “core temperature” of the patient. To obtain this noninvasively (i.e. without inserting a probe into the brain itself) we have two options:

- Nasopharyngeal probe: A thermocouple wire inserted into the sinus cavity.
- Tympanic probe: Measures the temperature of the ear drum.

Swimmer’s wax is used to secure these probes and prevent ice-cold water from entering the nostrils or the ears.

In addition, for comparison, it is useful to have another record of internal body temperature, and for this purpose we use a thermocouple wire mounted in a rectal plug. The plug is inserted into the rectum as soon as the patient is placed in the ice bath, and an inflatable collar around the plug prevents it from being dislodged. The collar also helps to prevent leakage of fecal matter into the ice bath, and should prevent ice-cold water from entering the rectum and creating a false temperature reading.

The output from each thermocouple probe is plugged into a temperature logging device, which should be enclosed in a waterproof box that will accompany the patient through subsequent stabilization procedures and during transport to the cryonics organization. This is especially important when the patient is shipped before cooldown has been completed, or when the patient travels as air cargo during summer or winter months and may be in a high-temperature or low-temperature environment for sustained periods.

## **Quantifying the Benefits of Cooling**

Regrettably, if we assess case histories during the past decade or more, we find that good temperature data often have not been recorded. Typical problems include:

- Probes were incorrectly placed.
- Probes were not securely placed, and became dislodged.
- Probes were contaminated with ice-cold water.
- Probes were never plugged in to a data logger.
- The data logger was not set up properly.
- The data logger was never started.
- The data logger was left out of the shipment.
- The batteries in the temperature logger failed.

These errors are understandable in that personnel may be fully occupied with procedures for intervention, during which data logging may seem a low priority. Still, data is essential to evaluating the outcome of a case.

Let us suppose that we do obtain good temperature data showing the rate of cooling during the stabilization. To make sense of this data, we need to know:

- What is an acceptable cooling rate?
- What would be an optimal cooling rate?
- What conclusions can we draw regarding brain preservation?

In ideal circumstances we want to cool so fast that energy will not be depleted and the brain remains viable by contemporary criteria. In reality, such cooling rates cannot be achieved through external cooling. However, one of the authors (de Wolf) has found that a cooling rate of about 0.18 degrees Celsius per minute is sufficient to inhibit the development of the so called

“no-reflow phenomenon” in the rodent model. This cooling rate is within reach when aggressive external cooling is combined with vigorous cardiopulmonary support.

Because there are no known adverse effects of high cooling rates, there is no limit on the rate that cryonics organizations should strive for. The faster the patient is cooled, the better. The calculation of an optimum cooling rate, using very conservative assumptions, is shown below.

Even the combination of rapid cooling and mechanical cardiopulmonary support may not be sufficient to prevent energy depletion of cells, especially when stabilization is followed by long transport times (cold ischemia). In such cases the best that can be hoped for it to prevent structural injury to the brain so that there will be little guesswork necessary as to the patient’s memory and identity in the future.

### **The Q10 Rule**

A very simple rule suggests an approximate relationship between temperature and metabolic rate. This is the “Q10 Rule,” which states:

**For every 10 degrees Celsius drop in temperature,  
the metabolic rate decreases by 50%.**

We can think of this as meaning that the rate of damage to cells in the brain decreases by a factor of 2 for every reduction by 10 degrees. A simple table will show this more clearly:

Patient Temperature (degrees Celsius)	Metabolic Rate (1=normal)
35	1
25	1/2
15	1/4
5	1/8

This rule may vary between species and in different organs and cells, and may not tell the complete story, because even modest reductions of brain temperature can have profound neuroprotective effects. Still, the Q10 rule is very useful for evaluating the benefits of cooling in cryonics because of its simplicity and its conservatism.

## **Other Systems of Measurement**

Two authors have attempted to develop formulas to evaluate brain injury more accurately when hypothermia is induced.

In *Cryonics* magazine (2nd Quarter, 1996) R. Michael Perry contributed an article titled “Toward a Measure of Ischemic Exposure.” Perry’s Measure of Ischemic Exposure (MIX) calculates how long the patient has been at a given temperature, with a higher weighting used for higher temperatures. For example, using an exponential rule, one hour at 0 degrees Celsius corresponds to a MIX of 1, 1 hour at 10 degrees Celsius corresponds with a mix of 2, 1 hour at 20 degrees Celsius corresponds with a MIX of 4, and so on.

Steve Harris, MD has proposed a similar metric, the Equivalent Homeothermic Ischemic Time, which he abbreviates as the “E-HIT.” In an incomplete and unpublished manuscript, Harris uses the E-HIT formula to calculate the equivalent normothermic ischemic time for different cryonics case scenarios and real cases.

Unfortunately neither Harris nor Perry reached a final, definitive conclusion, and the development of a formula to express brain injury as a function of temperature reduction over time remains a work in progress. The issue is complex because in an ideal cryonics case, pronouncement of legal death is followed by three interventions, all of which may contribute simultaneously to the inhibition of injury:

- Restoring oxygenated blood flow to the brain via cardiopulmonary support.
- Administration of neuroprotective drugs.
- Induction of hypothermia.

Moreover, in some cases these procedures may begin very soon after cardiac arrest, while in others, an hour or more may elapse before legal death has been pronounced and intervention may begin.

An ambitious program of research would be required to establish the degree of brain damage that is likely to result from different combinations of these factors—for instance, if cooling is applied but medications are unavailable, or if medications are administered rapidly but for logistical reasons, an ice bath cannot be used.

Another complicating factor is that oxygenation in combination with low perfusion pressures might produce more injury than “anoxic cardiopulmonary support” (chest compressions without ventilation).

In an effort to reach some tentative conclusions, one of the authors (de Wolf) has collaborated with R. Michael Perry. They began with the following simplifying assumptions:

1. The patient is not ischemic prior to pronouncement of legal death.
2. Cooling is initiated immediately after pronouncement of legal death.
3. There is no cardiopulmonary support or administration of neuroprotective agents.
4. Brain injury starts at 5 minutes of warm ischemia.
5. We assume that the Q10 rule is valid.
6. No other forms of injury occur, other than ischemic injury.
7. Ischemic injury is completely eliminated at the glass transition temperature of the vitrification agent M22 (-123.3 degrees Celsius).
8. A constant cooling rate is assumed.

With these assumptions, Perry calculated that to stay ahead of the brain injury that would normally begin after 5 minutes of warm ischemia, a cooling rate of 2.89 degrees Celsius per minute is necessary. Such a rate cannot be achieved by any known intervention. Therefore, cooling alone is insufficient to enable optimum brain preservation. This strengthens the case for

administering cardiopulmonary support (CPS) to maintain metabolism and homeostasis as best as possible during cooling rather than ischemia or anoxia.

Even so, it may not be possible to maintain complete viability of the brain in a cryonics case, even under optimal circumstances. However, we must emphasize that complete protection should not be necessary.

Numerous case studies describe successful resuscitation of patients who have endured an hour or more of accidental hypothermia in “natural” conditions, such as immersion in snow drifts or ice-cold river water. Even more impressively, hospital patients have been revived successfully after half an hour of hypothermic surgery during which there is no pulse, no respiration, and no measurable brain activity.

We may reasonably hope that cryonics patients can be revived in the future at a time when ischemic injury is much better understood than it is today, and injury can be reversed either pharmacologically, or by nanotechnology, or both. Since this issue remains speculative, we must simply try to do the best we can to minimize injury, and rapid cooling is the most important method to achieve this.

## **Thermoregulation in Cryonics Patients**

Even after cardiac arrest and the pronouncement of a patient, the human body may attempt to resist the induction of hypothermia via reflexes that would constitute a survival strategy under normal circumstances. This is known as *thermoregulation*.

### *Vasoconstriction*

By constricting blood vessels near the skin, the body attempts to retain as much heat as possible at its center. This, of course, is precisely the opposite of what we wish to achieve during cooling. Chest compression-induced vacuum vasodilation of the surface capillaries of the arms and legs may be effective in reversing this vasoconstriction

### *Shivering*

The purpose of shivering is to sustain metabolism via rapid muscular contractions. This phenomenon is controlled by the hypothalamus, and is the body's second line of defense, after vasoconstriction has occurred. If we achieve some success in protecting the brain, it may induce shivering after death, leading to the paradoxical conclusion that the more effectively we intervene, the more likely we are to find the patient's reflexes attempting to defeat our efforts.

Shivering is highly undesirable during patient stabilization as it consumes the remaining reserves of energy in the body. Fortunately, general anesthesia impairs thermoregulation, and thus can be mitigated by the administration of propofol.

Shivering can also be inhibited by neuromuscular blockers. One major disadvantage of using such agents is that their ability to depress spontaneous respiration can make a cryonics organization vulnerable to suspicions of hastening death prior to pronouncement. Another limitation of such agents is that their ability to inhibit shivering may not necessarily prevent the increase in metabolic rate that precedes shivering. Most importantly, the need for additional agents to inhibit shivering in cryonics patients should be reduced, if not eliminated, when general anesthetics are used to depress cerebral metabolism and to prevent the recurrence of consciousness during cardiopulmonary support. It should be reiterated once more that concerns about defeating thermoregulatory defenses may be only applicable to a small portion of "ideal" cryonics cases that do not feature age related, agonal, and ischemic-induced impairment of thermoregulation.

### **Benefits of Hypothermia**

One of the strengths of rapid induction of hypothermia in cryonics patients is that its benefits resemble those that can be gained by employing more complex interventions such as active compression-decompression cardiopulmonary support and multi-modal medications administration. As has been discussed in the section about quantification of cooling, very rapid core cooling rates would be able to prevent injury associated with ischemia even in



the absence of cardiopulmonary support and administration of medications. In this section we will review some of the technical benefits of hypothermia on the ischemic brain.

The finding that even mild decreases in brain temperature can confer long term benefits during ischemic insults raises the question of whether hypothermic neuroprotection can buy delays in energy depletion (depolarization) alone. For example, ischemia induced at hypothermic temperatures can inhibit the release of excitatory amino acids like glutamate into the extracellular space. At normal body temperature, ischemia produces a significant increase of these neurotransmitters; initiating glutamate receptor activated intracellular calcium influx and the start of a series of harmful consequences. Hypothermia can attenuate these excitotoxic events to a degree that exceeds what would be expected based on reductions of metabolic rate alone. Conversely, even modest cases of hyperthermia (about 39 degrees Celsius) increase the release of harmful neurotransmitters many times over what would be expected based on metabolic rate calculations alone. For this reason, the temperature of terminal cryonics members should be carefully monitored and, if possible, attempts should be made to persuade hospital staff to control the temperature of the patient to avoid hyperthermia.

Similar observations have been made about other elements of the ischemic cascade such as the formation of free radicals, inflammatory molecules, altered gene expression, apoptosis, proteolysis, and disruption of the blood brain barrier (BBB). Since increased permeability of the BBB is associated with increased edema during cryoprotective perfusion, maintaining the integrity of the BBB appears to be preferable in cryonics. As a general rule, progressive cerebral edema is observed in patients with progressive (warm) ischemic down time.

As can be seen from this brief discussion of the benefits of hypothermia, the benefits of rapid cooling exceed simple reduction of metabolic rate alone. From a physics perspective this observation is not completely satisfying because what else is a decrease of temperature than a decrease of average kinetic energy. The findings about the effect of hypothermia on biochemical events such as neurotransmitter release indicate that these processes should not be approached as ruled by a linear relationship with temperature but as

requiring a critical activation temperature. This explains why some adverse biochemical events following ischemia do not just decrease after moderate temperature drops but are inhibited altogether. As our understanding of the effects of temperature on biochemical processes grows we should expect a more individualized classification of how various biochemical pathways are affected by temperature.

## **Hypothermia and the “No-Reflow” Phenomenon**

When we think of the effects of oxygen deprivation on the brain we usually think of the injury to the cells or even the danger of autolysis. There is another risk associated with cerebral ischemia, and that is perfusion impairment in the brain. Researchers dating back to the 1960s have found that successive interruptions of blood flow to the brain result in increased areas of the brain that are never perfused, as evidenced by experiments performed with ink perfusion or modern imaging technologies. The development of no-reflow in cryonics is detrimental for a number of reasons including:

1. Incomplete circulation of cerebroprotective medications
2. Reduced metabolic support of the brain during cardiopulmonary support
3. Reduced cooling of non-perfused areas in the brain
4. Incomplete washout during remote blood substitution
5. Sub-optimal perfusion of the brain with cryoprotective agents

To mitigate the development of no-reflow the most important consideration is to establish immediate metabolic support of the brain through cardiopulmonary and vasoactive medications. Laboratory experiments have shown that the no-reflow phenomenon can be mitigated through high perfusion pressures and the administration of volume expanders with rheological effects such as Dextran 40.

There is in an ongoing debate between scientists and clinicians about the mechanisms involving no-reflow, but the correlation between energy

depletion, cerebral edema, and the development of perfusion impairment points in the direction of vessel constriction produced by ischemia-induced water movement. This is further evidenced by the finding of many researchers that drugs that prevent or dissolve blood clots, such as heparin and streptokinase, are not able to prevent or reverse the no-reflow phenomenon.

Further evidence for the hypothesis that energy depletion (as opposed to blood coagulation) is the main factor behind the no-reflow phenomenon comes from the finding that rapid induction of hypothermia after cardiac arrest eliminates the no-reflow phenomenon. No gross indications of cerebral no-reflow have been observed in rodent brains that have been rapidly cooled (~ 1 degrees C per minute) down to zero degrees Celsius. As mentioned earlier, experiments with cooling rates that can be achieved in human cryopreservation cases (~ 0.18 degrees C per minute) showed the same result. If these results hold, this means that the development of perfusion impairment in the brain can be prevented in cryonics by a combination of prompt cardiopulmonary support and placing the patient in an ice bath with circulating ice water.

Induction of hypothermia can slow down energy depletion and its consequences but cannot eliminate it. This applies to the development of no-reflow during cold ischemia as well. Research in rodents shows that the beneficial effects of hypothermia on no-reflow start to disappear around 5 hours of cold circulatory arrest (without blood washout). Since the tolerable limits for the benefits of hypothermia to prevent perfusion impairment fall in the same range as the documented records for whole body hypothermic resuscitation and isolated brain resuscitation (3-5 hours) attempts should be made to keep the time between pronouncement of legal death and start of cryoprotectant perfusion under 5 hours until there is conclusive evidence that viability and vascular potency can be maintained for longer periods of time. Successfully cryoprotectant perfusions of humans have often been performed after longer than 5 hours of cold ischemia, sometimes even after 24 hours or more. However this is clearly not desirable, and the effects on brain structure of such long delays are not well-understood.

## **Adverse Effects of Hypothermia**

Unlike other cryonics interventions such as cardiopulmonary support and administration of medications, the lowering of temperature constitutes the essence of cryonics. Therefore, if there are any disadvantages associated with cooling per se (as opposed to ice formation), attempts can be made to mitigate them, but cooling cannot be avoided. What can be done is to reduce the time that a patient must spend at hypothermic temperatures, prior to cryoprotection, by increasing the cooling rate and decreasing transport time. Strictly speaking, long transport times do not constitute an adverse effect of hypothermia, but it is important to be aware of the fact that extended periods of cold ischemia (more than 5 hours) will lead to energy depletion-induced movement of fluids between the vessels, the interstitial space, and cells, which can produce perfusion complications during cryoprotectant perfusion. The ideal non-technical solution to these problems is to minimize the time between pronouncement of legal death and start of cryoprotectant perfusion by good logistical planning and encouraging members that are critically ill to relocate to areas that are close to cryonics facilities while they are still alive.

Some of the adverse effects of hypothermia are not important in cryonics. Examples of such adverse responses include physical discomfort associated with lower core temperatures or the development of arrhythmias and cardiac arrest at low temperatures. Other effects are of a mixed nature such as the vasoconstriction associated with cooling of the extremities. Vasoconstriction improves blood flow to the core organs but decreases the rate of cooling of the core of the body.

The adverse effects of hypothermia pertain to the effect of low temperatures as such on the structure and functioning of cell membranes, proteins, energy generation and membrane-embedded pumps that regulate fluid balance.

Of greatest concern in cryonics is the fact that, as temperatures decrease, biochemical reaction rates decrease more than physical diffusion rates. As a consequence, cold-induced inactivation of cellular pumps can lead to an undesirable influx of water into cells. To prevent or delay such cellular edema, the blood of the patient can be replaced with a universal organ preservation

solution such as MHP-2 which includes impermeant agents designed to prevent such passive water movement.

Another adverse effect of hypothermia is increased viscosity. Increased viscosity will limit the speed at which cryoprotective agents can be equilibrated with cells. As a general rule, cryoprotective agents are perfused at temperatures close to zero to decrease toxic effects. In the case of cryoprotective agents like glycerol, however, such temperatures are highly impractical because permeability of glycerol at zero degrees Celsius is negligible, necessitating perfusion at higher temperatures, resulting in increased dehydration of the brain. It is important for team members to be aware of the effects of temperature on viscosity and permeability of cryoprotective agents and the trade-offs of perfusing at higher temperatures.

As a general rule, decreasing core body temperature produces increasing adverse effects in human beings. Unlike some hibernating organisms, decreasing the temperature in humans will not produce a corresponding drop in heart beat and respirations until the danger of ice formation presents itself. The human heart will stop beating toward the lower end of the deep hypothermia spectrum. In clinical medicine, however, induction of deep hypothermia is utilized for complicated surgical procedures that require complete cessation of circulation. In these procedures great care is taken to protect patients against the adverse effects of lower temperatures. Despite the obvious advantages of rapid cooling to the temperatures of water ice, it should be kept in mind that currently no human beings are routinely resuscitated from profound or ultraprofound hypothermic temperatures as an elective procedure in contemporary medicine.

## **A Pictorial History of Portable Ice Baths**

### **The MALSS**

The Mobile Advanced Life Support System (MALSS) was designed for Alcor Foundation by Jerry Leaf and Mike Darwin during the 1980s. Its objective was to enable rapid cooling, femoral cutdown, and blood washout in remote locations such as a mortuary or even a private residence. It utilized an ice bath consisting of a vinyl liner supported by a frame of PVC pipe, mounted on top of a Ferno-Washington collapsible gurney. Hugh Hixon of Alcor recalls that the longitudinal frame was reinforced with chrome-molybdenum 4140 tubing, while a DC power system was added to drive a 24-volt Sarns roller pump for perfusion. Provision was included for a side-mounted Michigan Instruments Thumper, and the unit was still in use as late as 1995 in a case performed by Biopreservation, Inc. for CryoCare Foundation.

The MALSS was extremely important conceptually, since it introduced the concept of an all-in-one device for rapid cooling and blood washout. It was not air-transportable, and its weight made it difficult to move in any vehicle lacking a lift gate.

### **The Pizer Bath**

In collaboration with Mike Darwin, long-time Alcor member David Pizer conceived of a simplified ice bath, similar in construction to the bath on top of the MALSS. A vinyl liner was supported by a frame of PVC pipe mounted on a sheet of 3/4" plywood, with wheels enabling the bath to trundle along at floor level. The vinyl liner was supplied by Pizer, who at that time owned a business selling replacement automobile seat covers.

The Pizer Bath allowed use of a Thumper but offered no capability for blood washout. It satisfied the need to carry a patient securely with at least 100 lbs of ice, and was used in several cryonics cases. Its great advantages

were low cost and simplicity, enabling regional groups to make their own copies. For many years, a Pizer bath was part of the standard equipment in the New York chapter of Alcor Foundation, and was stored at the home of cryonics pioneer Curtis Henderson in Sayville, Long Island. Henderson is shown beside the ice bath in Figure 11-8.



*Figure 11-8. Curtis Henderson with a Pizer Bath.*

The Pizer Bath could not be disassembled for air transport, and its choice of materials gave it a home-made look which would not help team members seeking respect and acceptance from medical personnel.

An SCCD was added, consisting of a 115-volt AC sump pump circulating water from the bottom of the ice bath through lengths of perforated hose that were draped over the patient. Figure 11-9 shows a couple of loops of hose with Henderson, who enjoyed posing for photographs of this type.



*Figure 11-9. Curtis Henderson with the SCCD.*

## **The MARC**

Hugh Hixon developed the Mobile Alcor Rescue Cart, or MARC, at Alcor in the early 1990s, using lessons learned from the MALSS. Hixon's design was highly ambitious, incorporating not only the pumps needed for blood washout but also a pair of oxygen cylinders, everything being installed in a custom-welded frame of gray-painted square-section steel tubing. In Hixon's words: "It was designed to be completely autonomous; all you had to do was get it there."



The MARC was used in several cryonics cases but was not air-transportable, and was so heavy, merely raising it to traverse a curb at the side of the road was a challenge. It could not be moved up or down a flight of steps, and could not be taken across soft ground. Two photographs of it are shown in figures 11-10 and 11-11.

The ambulance owned by Alcor for many years was fitted with a lift gate capable of raising or lowering the MARC, and a similar lift gate was installed for the same purpose on Alcor's rescue vehicle purchased in 2003. The MARC remains at Alcor but its future remains uncertain, since an intermediate-height ice bath was installed in the rescue vehicle in 2009.

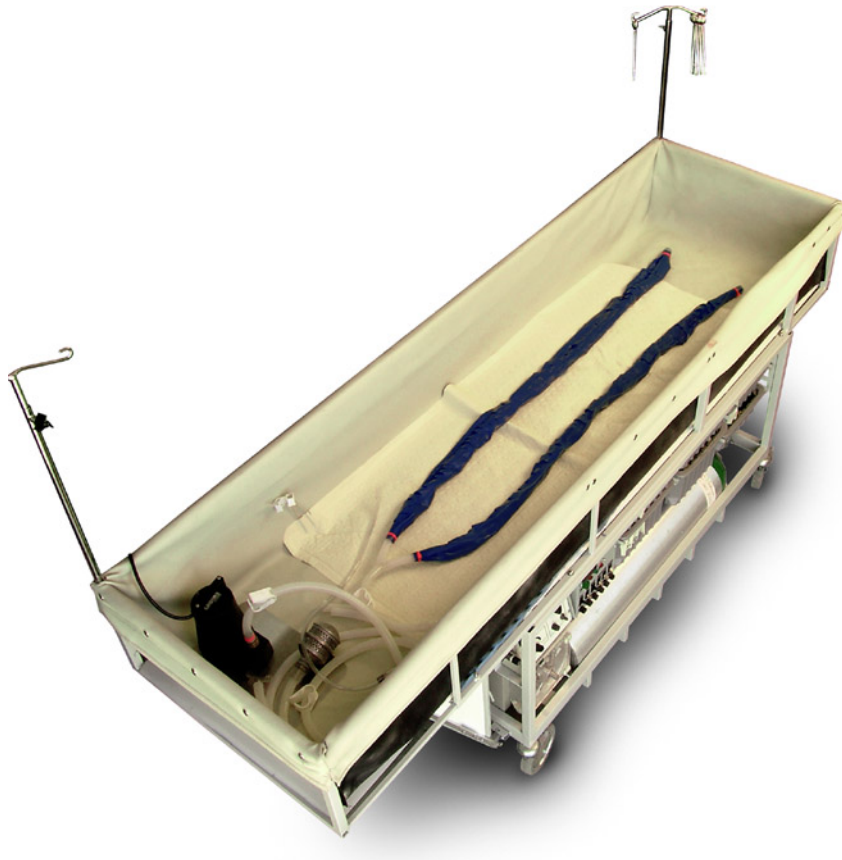

*Figure 11-10. Hugh Hixon's MARC viewed from above. The tubes inside it are a SCCD device.*



*Figure 11-11. Another view of the MARC, showing roller pump, data display, storage drawers, and one of two aluminum oxygen cylinders.*

## **The First Platt Design**

When Michael Darwin left Alcor and started Biopreservation Inc. as a service provider for CryoCare Foundation, he expressed interest in a new design of ice bath that would be fully collapsible for air transport. Charles Platt created a scale model of a concept which was approved by Darwin, but Platt lacked a workshop in which to build the final version, and commissioned this from Julian LaVerdiere, a New York artist who had a personal interest in cryonics. LaVerdiere used 1"x1" aluminum tubing and honeycomb-core plastic panels that formed a baseplate in the bottom of the bath. This was the first portable ice bath to have a “designed” look.

Like the Pizer Bath, Platt’s bath was intended to roll at floor level. Unfortunately Darwin failed to supply a detailed specification. Consequently, no provision was made for an IV pole, and Platt was unaware of the weight of

ice that the bath would have to carry. There were doubts about the stability of its zig-zag structure under full load, and during a test one of the honeycomb panels that La Verdiere had chosen cracked, apparently because it was weakened by prolonged exposure to zero-degree temperature. Engineer Mark Connaughton salvaged the design by installing a very strong stainless-steel baseplate, but the bath became too heavy for transport as checked baggage on commercial airlines.

The zigzag folding design is shown in Figure 11-12, while the opened bath is in Figure 11-13, with LaVerdiere beside it.

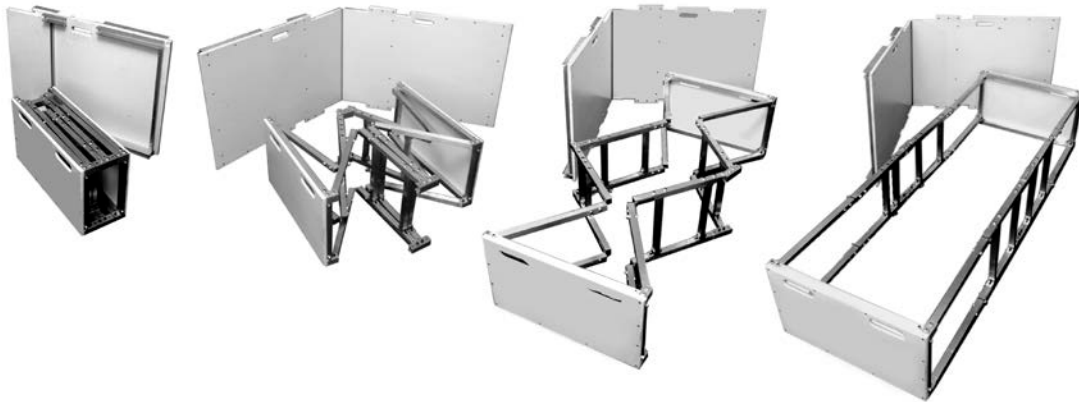

*Figure 11-12. The ice bath designed by Charles Platt and built by Julian LaVerdiere for Biopreservation, Inc.*



*Figure 11-13. New York artist Julian LaVerdiere beside the ice bath that he built.*

## **The Chamberlain PIB**

When Fred and Linda Chamberlain acquired a significant role at Alcor in the late 1990s, they introduced yet another ice-bath design, this one intended to be so minimal, multiple copies could be created very cheaply and distributed to

regional groups. It consisted of two thin, X-shaped folding tubular frames which were designed to support the opposite ends of a heavy-duty body removal bag. Instead of an SCCD, two rows of shower heads were clipped along each long edge of the body bag to spray ice-cold water over the patient inside it. This was necessary since the bag was not capable of holding much ice.

The assembled bath fulfilled its objective for being cheap to build and easy to store, but it had very little structural strength. It could be used only by placing it on the floor or a table, although Hugh Hixon suggested that if it was used on a gurney in a hospital, probably no one would notice if the gurney was rolled out of the building while cooling was in progress.

There was concern that the tubular frames could collapse during use, dumping ice water out of the body bag, although we can find no reports of this actually happening. In addition the shower heads were deemed impractical for many cases as they would be spraying recirculated water from inside the bag, which might contain fecal matter or blood. Mist from the spray would be an infection hazard when a patient was infected with hepatitis-C or similarly easily transmissible pathogens. No surviving examples of the Chamberlain ice bath appear to exist.

## **The Sinclair Design**

In England, cryonics activist Alan Sinclair created his own ice bath for use in an ambulance that he purchased personally. Sinclair used pieces of plastic pipe, similar to the design of the Pizer Bath, but he preassembled the pieces into modular sections and color-coded them for quick assembly. The Sinclair bath is probably the best compromise that has been achieved between simplicity, cheapness, and performance. At the time of writing, it has not been used in a cryonics case. Its drawbacks are that it is an exclusively floor-level design, and retains some of the nonmedical, “home made” look of the Pizer Bath.

Figure 11-14 shows the bath in sections that are assembled on the floor of Alan Sinclair’s living room.

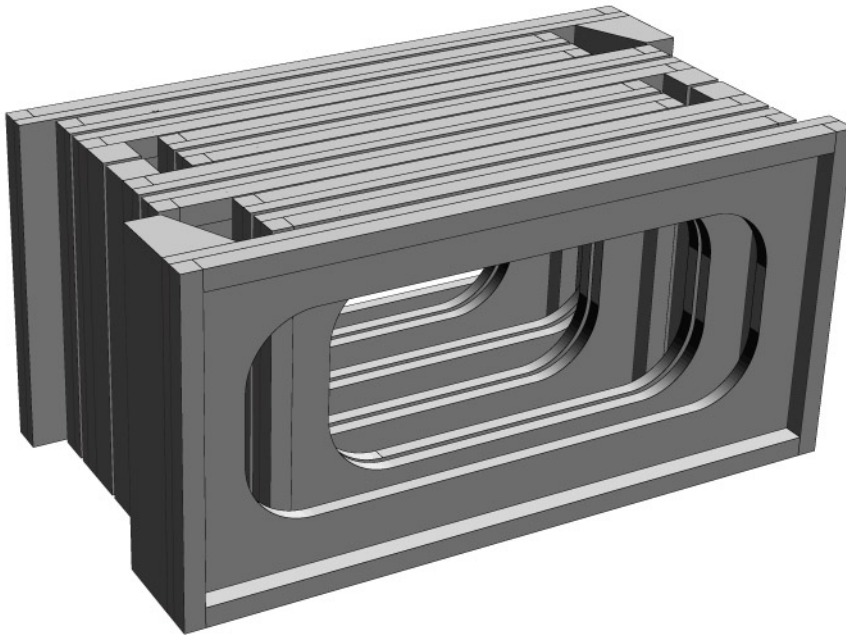

*Figure 11-14. Alan Sinclair's PIB design at his home in East Sussex, UK.*

## **The Second Platt Design**

In 2002 David Shumaker at Suspended Animation, Inc. asked Charles Platt to come up with another ice-bath design. Platt still liked the idea of sides that would unfold rapidly so that the bath could be easily deployed and would not

have any loose pieces that could get lost. He imagined fabricating it from Formica-clad half-inch plywood, for lightness and ease of construction. Two renderings that he prepared are shown in figures 11-15 and 11-16.



*Figure 11-15. A proposed design by Charles Platt would have been fabricated from Formica-clad plywood. It was never built.*



*Figure 11-16. The design shown in Figure 11-16, partially unfolded.*

## **The Shumaker-Quinn Design**

In 2003, while Michael Darwin was doing consulting work for Suspended Animation, Inc. in Florida, he and David Shumaker suggested a major revision of the portable ice bath concept. They wanted a bath that would allow procedures to be carried out at chest height (like the original MALSS) yet would be fully collapsible for air transport.

The finished design was built by Michael Quinn, who worked for Suspended Animation at that time. It used an aluminum baseplate, hinged in the middle and turned down at the edges to provide structural stiffness. Sockets were welded into the baseplate to accept lengths of 3/4" stainless-steel tube. They could be assembled on-site, using pins and screws, to form wheeled legs and a side rail. When all the sections of tube were disassembled, they would just fit inside the baseplate, which folded around them like a clamshell. The liner of the bath was a single, unstitched vinyl rectangle which



was inserted in the frame with its end corners turned inward, like an Origami fold. Strips of velcro on the liner held it in place. An SCCD was included, using a submersible marine pump that could be powered by a 12-volt battery.

This design was a radical step forward in many ways. An example is shown in Figure 1-17 with Darwin's ACDC Thumper installed (see Section 10 for a detailed description of Thumper variants).



*Figure 1-17. The PIB created by David Shumaker and Michael Quinn for Suspended Animation.*

The major defect of the design was its assembly time. Quinn claimed he could put all the sections of tubing together within half an hour, but when Ben Best at the Cryonics Institute took delivery of a bath and tried to assemble it, he said he gave up after two hours. In theory, many of the parts were interchangeable; in practice, small errors in the placement of holes drilled through the tubes forced a series of trial-and-error assembly attempts, and a rubber mallet was essential. The pins to secure the tubes were easily lost, and the complete package exceeded size and weight limits on some airlines. While the bath was conceptually important, it was not practical.

David Shumaker subsequently commissioned a completely new Thumper design from Michigan Instruments. This straddled the ice bath by using clamps on the side rails, and together with the depth and width of the ice bath itself, would accommodate very large patients. A privacy cover was included, completely concealing the patient while allowing continuing Thumper use through a zippered slit in the center, as shown in Figure 1-18.



*Figure 1-18. The final version of the Shumaker-Quinn ice bath included a redesigned Thumper chest-compression device, and a removable zippered privacy cover secured with Velcro.*

## **The Third Platt Design**

After Charles Platt joined at Suspended Animation, he tried to retain the most popular aspects of Shumaker's design while simplifying the assembly process. Platt still believed it should be possible to have a design that would unfold as one piece. At this point he had the luxury of working with Piotr Ruk, a master welder.

Platt maintained the same bath size as the Shumaker-Quinn design, so that the redesigned Thumpers could still fit across the rails. He borrowed from Hugh Hixon's MARC the idea of end sections that could be retracted if the cart had to fit inside a small elevator or traverse tight turns in a hallway. The baseplate of the bath was made from expanded stainless steel mesh, welded to the stainless-steel frame.

Figure 1-19 shows then-employee Kelly Kingston demonstrating how the completed ice bath could be unfolded within a few minutes. Six steel pegs were required to maintain it in its unfolded mode, but they were retained on two-inch lengths of stainless steel braided wire, welded to the frame. Thus, there were no separate metal pieces other than the wheels and an IV pole, all of which would fit inside the bath when it was folded and stowed in a nylon bag. The design was heavy, being entirely made from stainless steel, but it was within airline weight limits, and Platt successfully took it on an airline from Florida to Arizona and back.



*Figure 11-19. The collapsible ice bath designed by Charles Platt for Suspended Animation. After assembly, each end section could be tilted upward to fit into small elevators or navigate tight turns in hallways.*

The bath was criticized primarily for its weight and cost of fabrication. For a second copy of the bath, Platt substituted thinner, 18 gauge square tubes instead of the 16 gauge that had been used previously, and he simplified the folding end sections. Three copies were made altogether.

Because Shumaker's idea of an ice bath that could be raised to chest height with detachable legs still seemed desirable, Platt created a set of legs that could be plugged into his ice bath design. These are shown in Figure 11-20. Like the ice bath, they were all in one folding assembly, with no loose

parts. The legs plugged into the same sockets in the underside of the bath that were used to retain the wheels. The wheels were then transferred to the bottom ends of the legs.



*Figure 11-20. A foldable set of legs for the ice bath shown in Figure 11-19.*

The same dimensions of this ice bath were used to make two additional noncollapsible copies with nonfolding legs to go into the vehicles being converted by Suspended Animation. This design is shown in Figure 11-21, and in Figure 11-22 with its ends turned upward to reduce the length for use in tight spaces.



*Figure 11-21. A noncollapsible variant of the Suspended Animation ice bath.*



*Figure 11-22. Ends of the noncollapsible ice bath in Figure 11-22 could be turned upward to reduce the length when necessary.*

One of the folding baths and one of the nonfolding baths have each been used in cryonics cases. A lowered version of the nonfolding bath is currently in Alcor's transport vehicle.

### **The Cryonics Institute Variant**

A variant of the final Platt ice bath was built for the Cryonics Institute at the request of their mortician, who wanted legs that would flip up so that he could slide it into his Chevy Suburban. This ice bath would never be deployed by air, as the Cryonics Institute did not run its own standbys. Therefore, the legs could be permanently attached, and the bath itself did not have to be collapsible. It is shown in Figure 11-23, and the design of the legs is illustrated in Figure 11-24.

The design was similar to that of a gurney of the type used by paramedics, but was heavier and stronger, being fabricated from stainless steel to carry a patient with large quantities of ice and water.



*Figure 11-23. This variant of the Suspended Animation ice bath was built for the Cryonics Institute.*





*Figure 11-24. The variant for the Cryonics Institute featured legs that could be retracted by pulling a lever, so that the bath would slide into a vehicle with limited head room, such as a Chevy Suburban. The bath was not air-transportable.*

## **10. The Van Sickle Design**

Alcor expressed interest in Platt's folding ice bath, but decided it was too expensive. While Steven van Sickle and Tanya Jones were developing new equipment for Alcor in 2007, they created an ice bath of their own, shown in Figure 11-25. This consisted of a slightly modified aluminum stretcher of the type used by rescue teams in mountainous areas.



*Figure 11-25. The ice bath designed by Steven van Sickle for Alcor.*

The advantages of this design were that it was light, cheap, and compact. The sections could be disassembled and stowed in a back pack, as shown in Figure 11-26. Unfortunately, the design also had one major disadvantage: it wasn't big enough. The bath could not accommodate tall or obese patients, and didn't have enough room for necessary volumes of ice and water. While it could be used with a side-mounted Thumper, its rounded bottom made it unsuitable for a LUCAS chest-compression device.

The design was used in one cryonics case, during which it sustained some minor damage. We are not aware of any cases where it has been used subsequently.



*Figure 11-26. The van Sickle ice bath was very compact.*

## **The Graber Ice Bath**

Steve Graber, at Alcor, developed a less compact but more robust ice bath to replace the van Sickle version. This is made from sections of painted steel that plug together. Graber is shown assembling the bath in figures 11-27, 11-28, and 11-29. This is the default ice bath used by Alcor at the time of writing. Its primary limitation is the number of separate parts. It is also smaller than the Shumaker-Quinn ice bath.



*Figure 11-27. Steve Graber at Alcor begins to unpack the ice bath that he designed.*



*Figure 11-28. Step two in unpacking the Graber ice bath.*



*Figure 11-29. The frame of Graber's ice bath, attached to its baseplate.*

## **Desirable Features for Portable Ice Baths**

The hypothetical ideal ice bath may still not exist, and may never exist, as its desirable features conflict with each other. They are summarized below.

### **Strong**

When loaded with a patient weighing up to 250 lbs, with 100 lbs of ice, 5 gallons of water, a chest-compression device, and ancillary items, an ice bath must still be strong enough to be lifted either by its base or by its side rail, from opposite ends and with no support in the middle. We cannot expect team members to follow special, restrictive instructions for handling the bath.

### **Transportable**

A portable ice bath should fold or disassemble to a size compatible with airline regulations for checked baggage. It must be sufficiently robust to withstand airline baggage handling.

### **Easy to Assemble, With No Loose Pieces**

An untrained person should be able to put it together. There should be no possibility of a person under stress losing pieces that are necessary.

**Not Too Heavy**

One person of average strength should be able to lift the folded bath, or its separated subsections (if any).

**Affordable**

Materials and fabrication time should be reasonable. No exotic materials should be necessary.

**Easy to Build**

No special skills needed.

**Compatible With CPS Devices.**

This requirement is less taxing than it used to be, as LUCAS devices have become widely used and fit in almost any ice bath except for the discontinued van Sickle design.

**Able to Accommodate Large Patients**

While we recognize that any piece of medical equipment must have design limits that exclude some patients, we feel that 6 feet 6 inches is a reasonable requirement. For obese patients, the bath should be 2 feet wide. To enable submersion of most of the skin area, the bath should be more than 1 foot deep.

**Retractable End Sections**

An ice bath of the size described above may not fit into small elevators or go around tight corners in hallways. Hugh Hixon's decision to use a retractable end section was prescient. This feature is not often needed, but can make the difference between an ice bath being usable and unusable in some cases.

**Convertible for Use With or Without Legs**

The bath should slide into a van or SUV but should also be usable at (or near) gurney height for surgical procedures. If removable wheels are used, they should be easy to plug in and unplug, but should never fall out accidentally.

**Usable With an IV Pole**

An IV pole should be easily attached to the ice bath, and height-adjustable to fit into vehicles.

**Usable With Medications**

Ideally, a tray should fit across the side rails so that meds can be laid out prior to being administered.

**Safe in Transport Vehicles**

When installed in a vehicle, the bath should be easily clamped and unclamped. When clamped in position, it must be secure against longitudinal, lateral, and vertical forces. The heavy load in an ice bath can cause it to injure personnel if it rolls around.

**Professional in Appearance**

The look of cryonics equipment may not be relevant to its function, but may play an important part in establishing credibility during standby/stabilization procedures. Credibility, in turn, can encourage cooperation from medical professionals.

## **12. Liquid Ventilation**

### **Introduction**

We use the term “liquid ventilation” here to describe multiple rapid infusions of the lungs with a breathable liquid capable of introducing oxygen and removing carbon dioxide. In cryonics applications, the liquid will be chilled for the purpose of rapidly cooling a patient.

Although boluses of cold perfluorocarbon liquid have been delivered to the lungs of at least one cryonics patient,[1] liquid ventilation by our definition has not been employed in a cryonics case at the time of writing. However, the procedure has been extensively tested in animal studies which initially achieved peak cooling rates of 0.5 degrees Celsius per minute[2] and later 1.0 to 1.3 degrees Celsius per minute (see Figures 12-1 and 12-2). These studies suggest that liquid ventilation has the capability to achieve cooling after cardiac arrest at several times the rate attainable by immersion in ice and water alone, and may cool the body more rapidly than any procedure other than extracorporeal bypass (ECB)[3] while being minimally invasive and appropriate for field deployment.



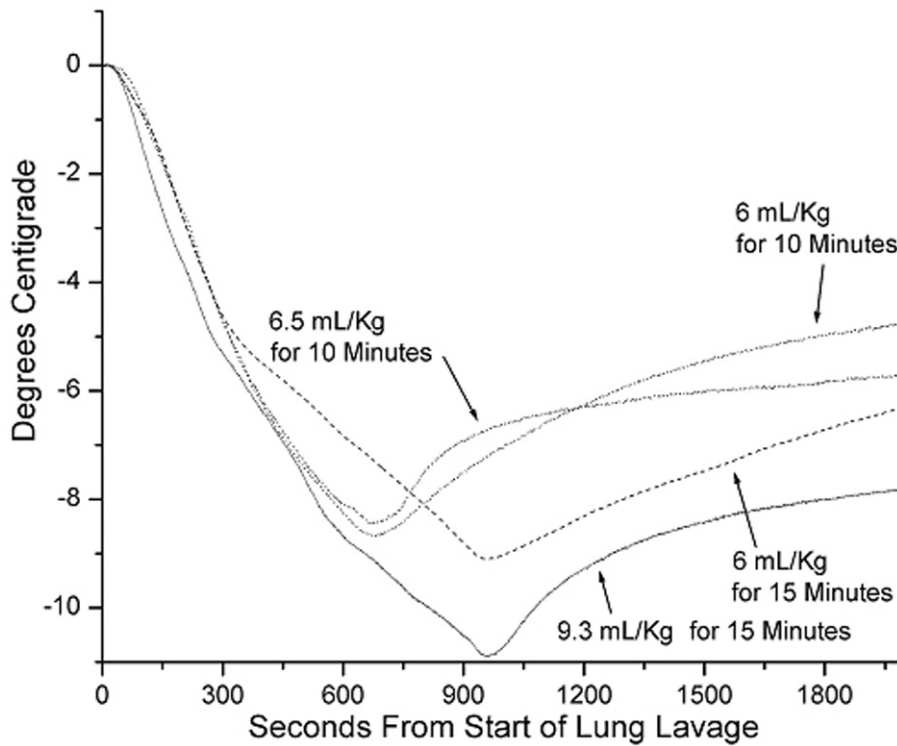

*Figure 12-1. Cooling curves from experiments with liquid ventilation devices. These curves were submitted with an international patent application in 2008. A peak cooling rate of greater than 1 degree Celsius was achieved repeatedly, and even at the lower temperature range of 9 to 11 degrees below normal body temperature, the lowest of the curves shows that a rate of approximately 2 degrees in 5 minutes was recorded (0.4 degrees per minute). Temperatures were measured tympanically.[3]*

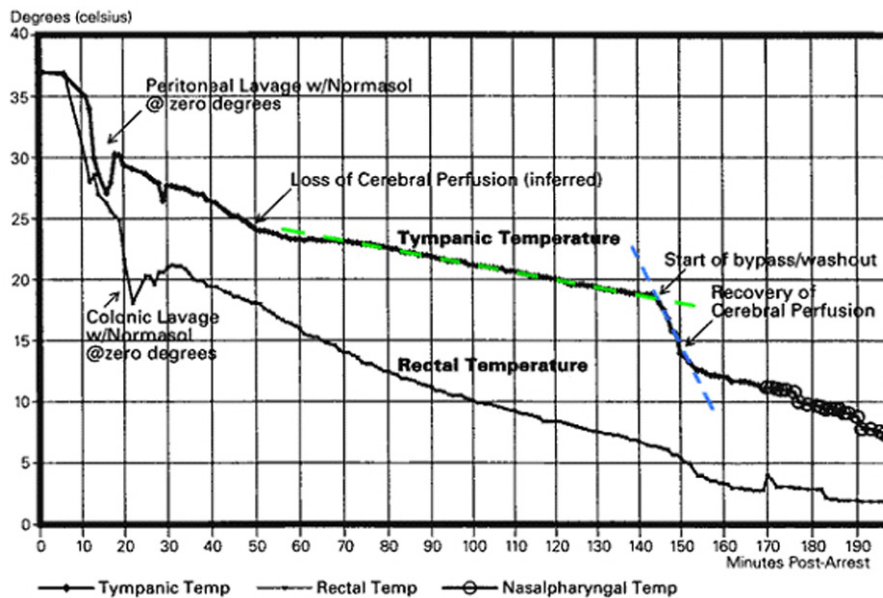

Figure 12-2. Cooling curves from a cryonics case show the approximate cooling rate when the patient received only surface cooling in an ice bath (green dashed line, about 0.06 degrees per minute) and was subsequently cooled via extracorporeal bypass (blue dashed line, about 1.3 degrees per minute).[3]

Because liquid ventilation requires no surgical procedures (only intubation), we may expect that it should be usable in many environments after pronouncement of legal death. By comparison, ECB usually entails removing the patient from the place where death was pronounced, loading the patient into a vehicle, and moving the patient to a location such as a mortuary where perfusion of the circulatory system with chilled organ preservation solution can be initiated. Relocating the patient, setting up and debubbling the perfusion circuit, and obtaining vascular access via femoral cutdown can impose a total delay of 2 to 3 hours, during which the patient typically receives nothing more than surface cooling in a portable ice bath while chest compressions continue.

Gravity-fed perfusion with stepped concentrations of cryoprotective solution has been introduced by Alcor for field neurovitrification, but this too requires relocating the patient to (usually) a mortuary where femoral cutdown

is performed. If it is preceded by liquid ventilation, cooling will be achieved more rapidly.

In both of these scenarios we believe that a portable liquid ventilation device can be located at the bedside for use within minutes after a patient has been pronounced.

A liquid-ventilation prototype with the theoretical capability of cooling a human patient was completed and animal-tested successfully during 2011, but required manual adjustments and a skilled operator, and was never used outside of a laboratory. Several liquid ventilation prototypes were developed during 2011 through 2019 by Suspended Animation, Inc., but none has been tested with complete success. For more information, see the section titled Subsequent Developments, below.

## Origins and History

Fluorocarbons can have very low viscosity and low surface tension, are capable of dissolving oxygen and carbon dioxide, but are generally nonreactive and nontoxic. Certain fluorocarbons do not mix with either water or fats, so they can come into contact with cells and tissues without interacting with them chemically. These properties make them suitable as a substitute for air in the lungs.[4]

A *fluorocarbon* is a chemical compound containing carbon and fluorine atoms. A *perfluorocarbon*, or perfluorinated compound, sometimes referred to as a PFC, is a fluorocarbon containing only carbon and fluorine atoms. The two chemical terms now tend to be used interchangeably, but in this text we prefer *perfluorocarbon*, as it is the more accurate term to describe liquids currently being used for infusion of the lungs.[5]

The first successful experiments to ventilate the lungs with a liquid were described in a paper by Leland C. Clark, Jr. and Frank Gollan published in 1966.[6] The authors reported experiments with mice and cats that breathed perfluorocarbon liquids for up to one hour and were revived afterward without significant signs of injury.

Prior to 1966, experiments in liquid breathing had been pursued at the State University of New York at Buffalo by Johannes Kylstra, who reported

his work in 1962.[7] He used a saline solution which he managed to load with oxygen under high pressure, but the saline could not remove carbon dioxide fast enough, and severe respiratory acidosis was the unfortunate result. Unlike perfluorocarbons, saline can also cause lung dysfunction by dissolving surfactant that is naturally present inside the lungs to prevent alveoli from collapsing.

Kylstra later became familiar with the work by Clark and Gollan, and adopted perfluorocarbons in new research that he began in May, 1969 at Duke University Medical Center, with funding from the U. S. Navy's Office of Naval Research. The Navy was interested in the possibility of using a breathable liquid to address the problem of decompression sickness among divers, commonly known as "the bends." Because a significant pressure differential can cause the lungs to collapse, deep-sea divers must breathe air that is pressurized. However, nitrogen, found naturally in the air, tends to dissolve in tissues under pressure. When the diver resurfaces, the nitrogen returns to a gaseous state, forming bubbles that can cause pain and, in extreme cases, death. Because liquids are effectively noncompressible, and need not contain any dissolved nitrogen, Kylstra hoped that filling the lungs with a breathable liquid could eliminate the problems associated with decompression.[8]

The research at Duke continued until 1975, after which it was summarized in a report titled "The Feasibility of Liquid Breathing in Man." [9][10] Kylstra stated that dogs and rats had recovered fully, with little or no detectable lung damage, after one hour of breathing an oxygenated perfluorocarbon known as FC-80. While he admitted that the solubility of carbon dioxide in pure perfluorocarbon remained less than ideal, he claimed that the solubility could be enhanced by adding sodium hydroxide, to the point where divers would be able to perform active work while breathing the mixture.

Despite his recommendation, liquid ventilation was never widely implemented and remained a curiosity. Many people today are aware of it because they have seen James Cameron's motion picture *The Abyss*, in which a live rat is supposedly shown immersed in perfluorocarbon liquid and the protagonist uses the same technique to survive at an extreme depth. Cameron

has stated that he picked up the idea when he was a 17-year-old high-school student. Supposedly, he attended a science lecture in which a deep-sea diver described his experience breathing saline solution after volunteering for one of Kylstra's experiments.[11][12]

## **Medical Applications**

In addition to the possible use of liquid ventilation for deep-sea divers, Kylstra suggested that breathable liquids could be used in the treatment of respiratory problems. This idea attracted renewed interest in the late 1980s and early 1990s, at which time Alliance Pharmaceutical marketed perfluorooctyl bromide (a fluorochemical also known as perflubron) under the brand name *Liquivent*. This was used experimentally to treat premature infants who suffered acute respiratory distress syndrome (ARDS). Because perflubron was added to a flow of air or oxygen, and because the volume of liquid was usually no greater than residual lung capacity, the procedure was referred to as *partial* liquid ventilation (PLV), distinguishing it from Kylstra's earlier experiments which may be described as *total* liquid ventilation (TLV).[13][14] (Residual lung capacity is defined as the amount of air that remains in the lungs after expiration.)

ARDS cases had been traditionally treated with positive-pressure ventilation using oxygen, which can contribute to the development of lung disease. PLV promised to eliminate this risk, encouraging the FDA to allow "fast track" status, which permitted clinical trials. However, when additional trials suggested that the use of high-frequency oscillating ventilation with oxygen improved outcomes as much as using PLV with ordinary ventilators, the FDA chose not to approve perflubron, and Alliance discontinued it.[15]

In 1996, Mike Darwin and Steve Harris, MD started to develop an idea that had been proposed in 1984 by Thomas Shaffer, although he had never succeeded in making it work successfully.[16] If a perfluorocarbon is chilled before using it in liquid ventilation, it can lower the temperature of a human patient rapidly. A chilled liquid is far more effective for this purpose than a cold gas, because an equal volume of liquid is capable of removing many times more heat.

Infusing a chilled liquid would induce the lungs to function as an endogenous heat exchanger, taking advantage of their huge internal surface area, typically estimated to be about 160 square meters. Blood would be cooled as it flowed through the network of capillaries embracing the lungs, and would then circulate up to the brain, cooling it from within.[17] Such rapid cooling would be especially valuable for patients resuscitated after cardiac arrest, because mild hypothermia after resuscitation is known to reduce reperfusion injury.

Harris and Darwin also saw that if ventilation of the lungs with a chilled liquid continued for an extended period, it could induce deep hypothermia, making it ideal for cryonics patients, provided that some blood circulation could be maintained by chest compressions. The circulation would be required not only to continue oxygenation of the patient (if this was appropriate under the circumstances of the case) but also to convey warm blood from the brain the lungs, where it would be cooled before returning to the brain.

## **Cryonics Applications**

The first design tested by Darwin and Harris involved pumping perfluorocarbon liquid through pre-chilled cartridges containing highly permeable filters, as shown in Figure 12-3. Darwin described this work initially in a cryonics magazine, and coauthored a patent under the name Michael Federowicz.[18][19]

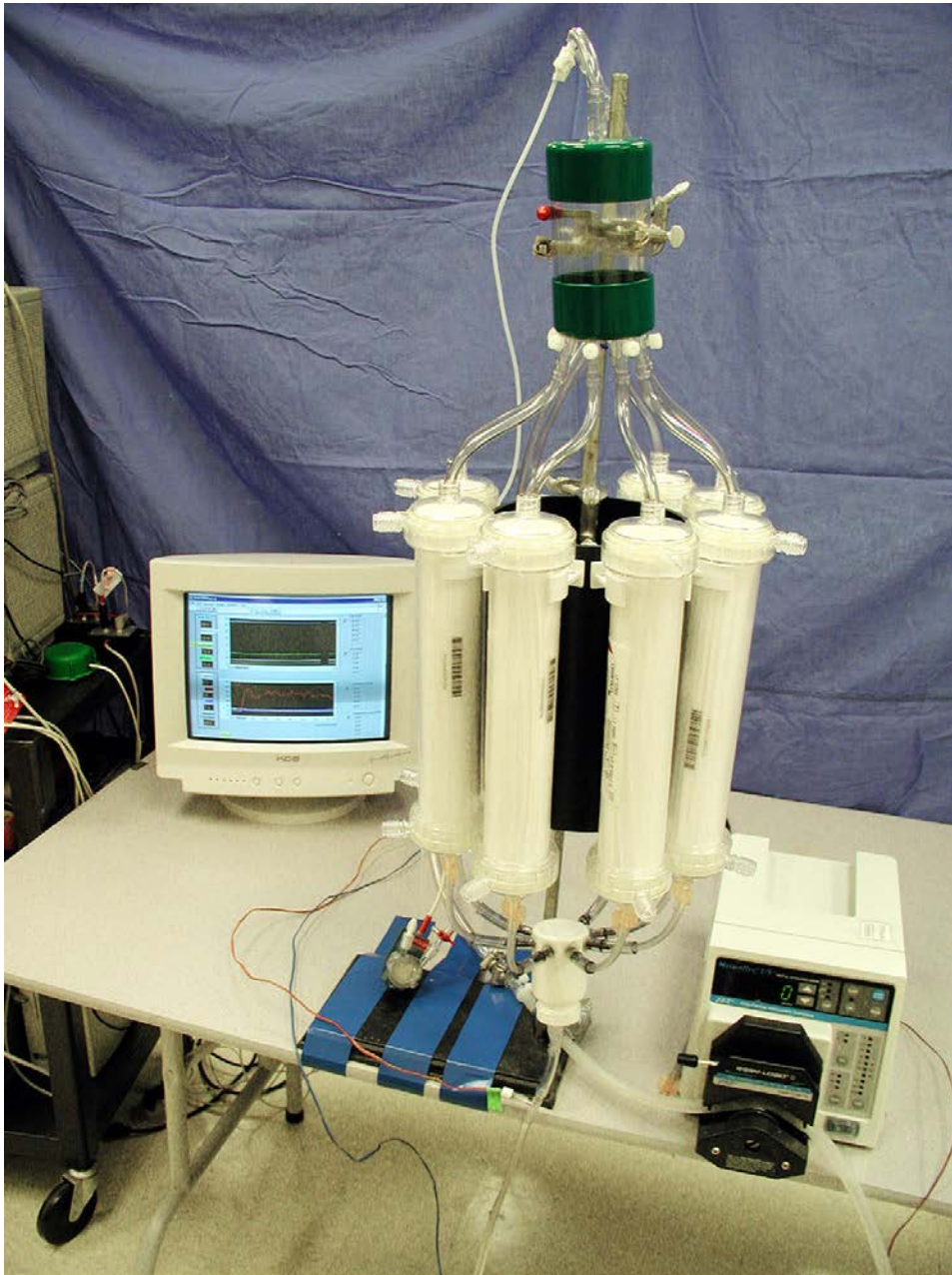

*Figure 12-3. This cartridge system for cooling and oxygenating perfluorocarbon liquid was used experimentally for total liquid ventilation in 1996.*

However TLV (using fluid but no gas) entails problems. While perfluorocarbon liquid has a low viscosity, it is still about 80 times that of air, limiting the number of infusions per minute. Moreover, no way has been

found to improve the removal of carbon dioxide that Kylstra identified as a problem several decades ago. More significantly for cryonics applications, Harris and Darwin were unable to achieve cooling rates which basic physics suggested should be available. They speculated that “thermal equilibrium is not reached between blood and liquid in small airways at high TLV ‘alveolar ventilation’ rates. Thus, there appears to be a heat-diffusion limitation to TLV.”[20]

To address these concerns, they developed a form of partial liquid ventilation which they described as *mixed mode*, adding gas in conjunction with perfluorocarbon liquid. They wrote: “We believe that the mixing of PFC and gas disrupts laminar liquid (PFC) flow in small airways by introducing turbulence to the fluid, thereby improving the small-scale (small airway) convection necessary for maximal heat transfer rates.” In a patent that was issued in 2004 they claimed that mixed mode liquid ventilation had achieved a cooling rate of 12 degrees C in 30 minutes—a net drop of 10 degrees after equilibration, representing an average of about 0.3 degrees per minute. Graphs included in the patent suggested a peak rate of about 0.5 degrees per minute.[20]

An engineering company was retained to create a portable version of this system. When the results were considered unsatisfactory, a second engineering company was brought in. Meanwhile, the laboratory version of the apparatus evolved and became simpler as a result of in-house improvements, but was not portable, which made it unsuitable for cryonics field work or deployment with paramedics in conventional medicine.

## **Designs by Suspended Animation**

In 2006, following unsatisfactory results from the second engineering company, Suspended Animation, Inc. in Boynton Beach, Florida developed a radically simplified, portable design. Charles Platt and Gary Battiato initially built a downsized replica (identified here as LV1) of the most recent laboratory version, as a proof-of-concept. This incorporated Battiato’s creative suggestion to use a Pelican brand transportable container not only to transport the equipment but also as an icewater reservoir, with a perfluorocarbon tank



located in the center. The tank was entirely surrounded by ice and water, which not only helped to cool the tank but also insulated it actively from its surroundings—so long as ice remained in the water to absorb heat via latent heat of fusion. Heat incursions through the sides and bottom of the Pelican container were overcome simply by adding more ice, and thus this configuration eliminated bulky insulation. The nested-reservoir configuration also made the device simpler to deploy and more portable. See Figure 12-4.

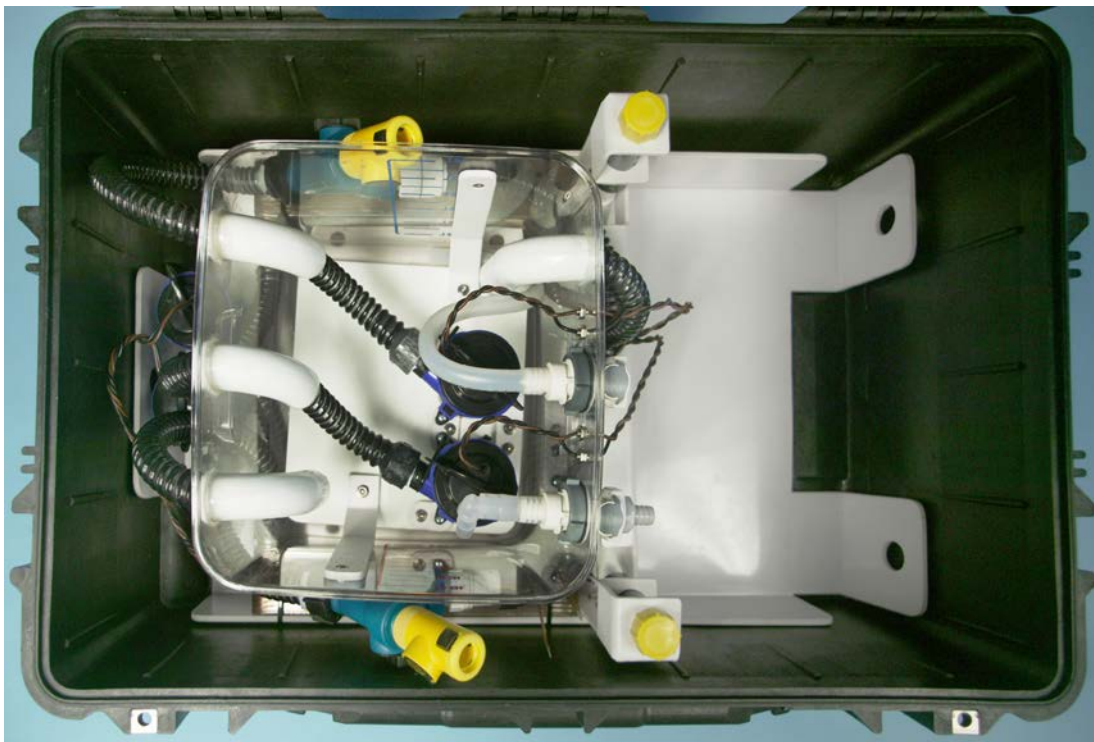

*Figure 12-4. The first liquid ventilation device, LV1, developed at Suspended Animation. In this very simple design, small 12-volt submersible, centrifugal marine pumps were used to cool the perfluorocarbon through a heat exchanger, and to deliver perfluorocarbon via an infusion tube (not shown). A diaphragm pump created suction to return perfluorocarbon liquid to the central reservoir. Infusion and suction tubes were inserted in the yellow quick disconnects. The device could be controlled either manually or via a single 555 timer chip.*

Shortly after the development of LV1, Darwin suggested that since liquid ventilation is likely to be used in conjunction with a portable ice bath, the heat exchanger in a liquid ventilation device could be cooled with water from the ice bath to avoid maintaining two separate reservoirs. While this suggestion seemed superficially attractive, it ignored several factors.

- The water in a portable ice bath may be contaminated with bodily excretions. Maintaining separation of the liquid ventilation system seems desirable for this reason alone.
- Provision would have to be made to avoid the risk of either overflows or a low level in the Pelican container, if water was pumped in or out.
- While the availability of a portable ice bath in conjunction with liquid ventilation is likely, it cannot be guaranteed. Various factors, such as damage to the bath or loss of the bath by airline baggage handling, may interfere. In some patient locations, moving a portable ice bath to the bedside may be impossible. The absence of an ice bath should not preclude the use of liquid ventilation.
- The design of LV1 used a pump to circulate water through a heat exchanger while simultaneously promoting circulation of water around the perfluorocarbon reservoir. Thus, one small pump served two purposes. Using water from a portable ice bath would require an additional pump to raise the water to the liquid ventilation system, and probably a second pump to return the warmed water to the ice bath, since a gravity feed might not be sufficiently rapid or reliable. Adding two pumps would increase the weight of the equipment and its power consumption, while also increasing the risk of equipment failure.
- Tubing to connect the liquid ventilation equipment with the portable ice bath would be vulnerable to kinks and accidental displacement during activity surrounding the ice bath. The tubing

would have to be insulated on the input side, which would add to its bulk and inconvenience. Even with insulation, the tubing would allow some heat incursion.

- Because of the large size of the portable ice bath, and the presence in it of a warm human body, “hot spots” would be likely in the bath. There would be no way to guarantee that water drawn from any particular location in the bath would be close to 0 degrees Celsius. Team members working under time pressure could easily make the mistake of drawing water from the ice bath in a location close to the patient’s body.
- The need for a portable ice bath would probably preclude the liquid ventilation equipment from being applied in conventional medicine.

Summing up, sharing water from a portable ice bath would add many problems while providing few benefits. By comparison, adding ice and water to the liquid ventilation reservoir provides several benefits and is a quick and simple operation.

Afer successful testing of LV1, Platt developed a radically different tubing circuit that was built into LV2, the next prototype to be developed. LV2 was demonstrated at the Suspended Animation open house event in 2007, and was then moved to California where it was animal-tested extensively, achieving an impressive peak cooling rate of approximately 1 degree Celsius per minute. (See Figures 12-1, 12-5, and 12-6.)



*Figure 12-5. The LV2 liquid ventilation assembly designed and fabricated at Suspended Animation and demonstrated in 2007. The control panel in the lower Pelican container could be lifted out so that ancillary items (such as the infusion pump and insulated delivery tube) could be stowed below it for transportation. Lids of the Pelican containers were removable, and the stainless-steel frame was disassembled for shipping in a separate box. The concept of a frame was discontinued in LV3 in favor of a simpler arrangement in which the two Pelican containers were stacked and a small wheeled subframe was added to the lower container. LV2 used a more powerful suction pump than LV1, but infusion was provided by the same small submersible pump as in LV1.*

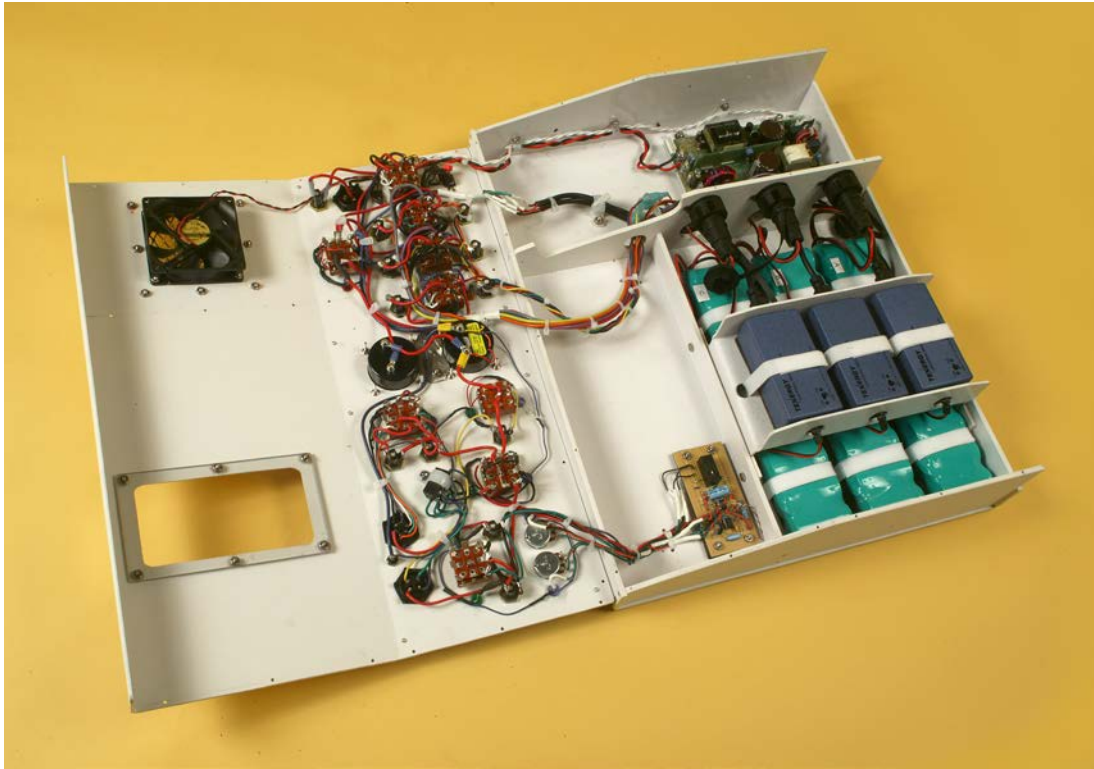

*Figure 12-6. The control panel for LV2, opened to reveal three battery packs and chargers, an AC-DC converter in a separate compartment, and very simple control electronics on a 2x4 inch circuit board.*

Platt relocated to California to work fulltime on design and fabrication of LV3. This new version incorporated suggestions and requests that had emerged during the testing of LV2. A larger suction pump addressed the issue of residual perfluorocarbon remaining in the lungs, and the primary Pelican case was redesigned to rest across the rails of a portable ice bath, above the patient's legs. This configuration was later abandoned as elevation of the suction pump above the patient greatly reduced its efficiency. The tubing circuit for LV3 is shown in Figure 12-7, while various views of the equipment are shown in Figures 12-8, 12-9, 12-10, and 12-11.

Liquid Ventilation System  
Charles Platt  
September 16, 2007

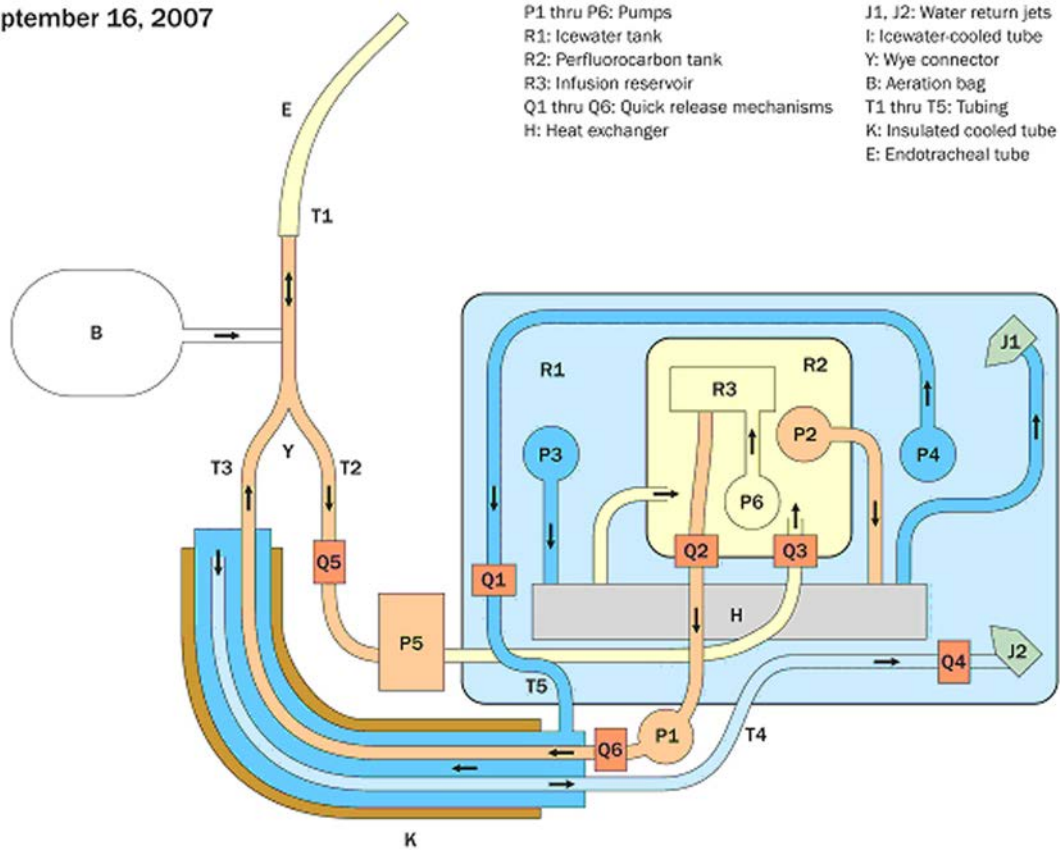

Figure 12-7. This diagram was created in preparation for a patent application filed in 2008. It shows the main components that were planned at that time for LV3, including the insulated delivery tube (K) with an icewater jacket, and external infusion and suction pumps (P1 and P5) to be mounted outside the Pelican container when the equipment was assembled.



*Figure 12-8. In LV3, batteries and chargers were mounted inside the lid of the primary Pelican container, alongside switches and control electronics. A more powerful infusion pump and a more powerful suction pump than in LV2 were mounted in a separate box, together with a small pump that cooled an icewater jacket on the delivery tube (the tube is not shown here).*



*Figure 12-9. The pump box for LV3 was located on a platform that could slide out to allow access to the perfluorocarbon reservoir below. The whole assembly was designed to sit above the patient's legs on the rails of a portable ice bath, but its elevation greatly reduced the efficiency of suction from the lungs..*



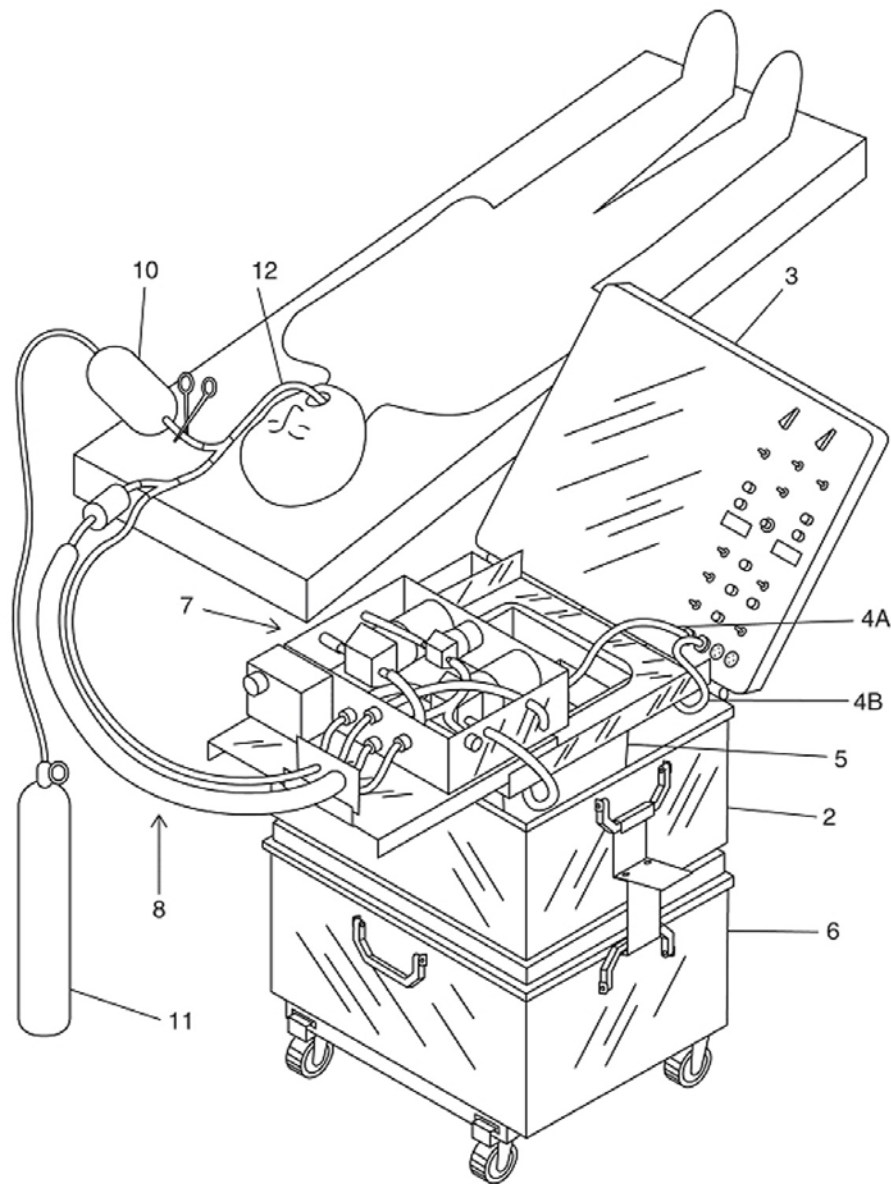
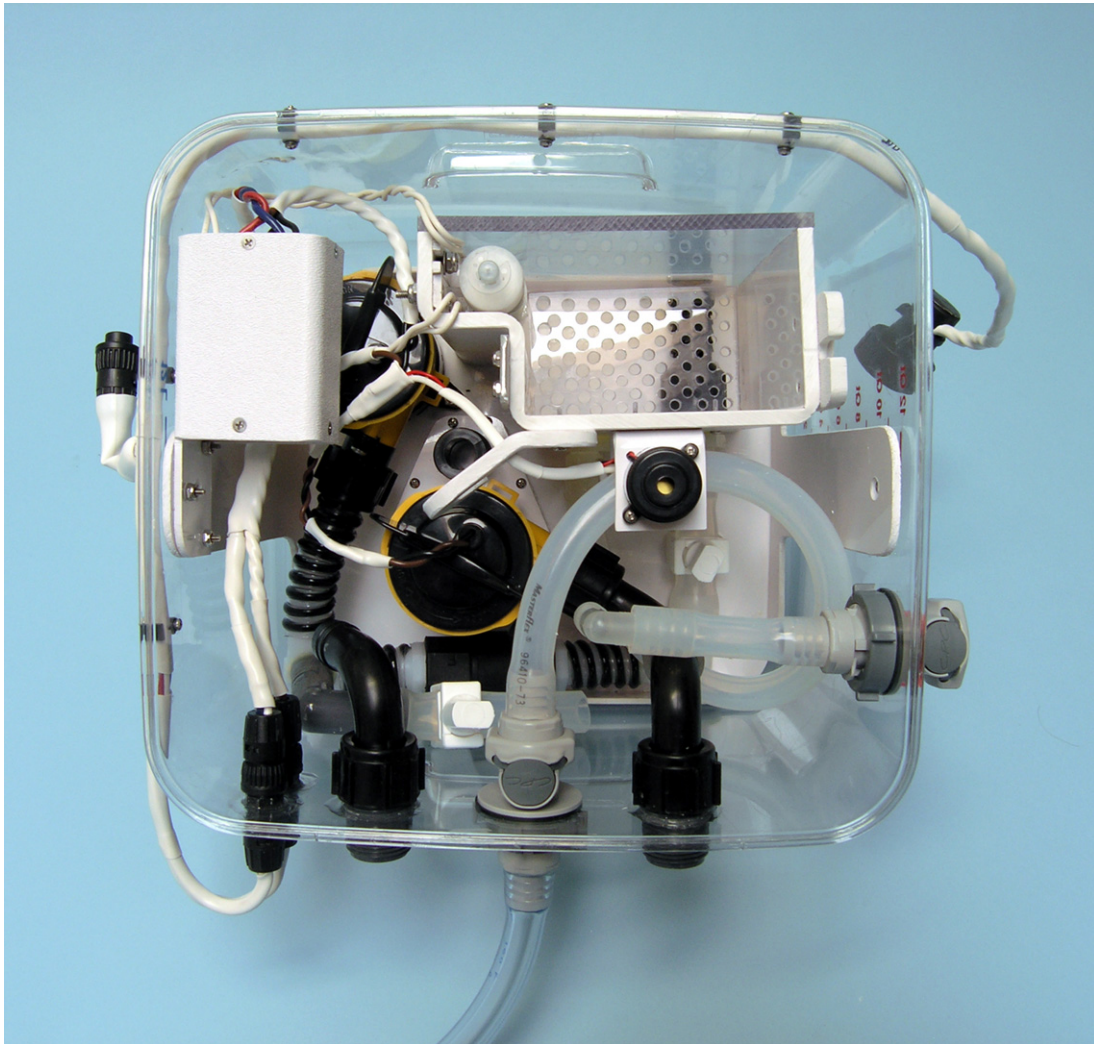

Figure 12-10. A diagram of LV3 that was included in the patent application in 2008, rendered in the style required by the U. S. Patent Office. Electronics in the lid of the primary Pelican container (3) control pumps on the upper tray (7) and in the perfluorocarbon reservoir below (5) via detachable cabling (4A, 4B). The jacketed delivery tube (8) can convey perfluorocarbon liquid to a hypothetical patient via an endotracheal tube (12), with oxygen delivered from a cylinder (11) via a conventional medical bag valve (10). Wheels beneath the secondary Pelican container (6) are on a removable subframe.



*Figure 12-11. Overview of the perfluorocarbon reservoir in LV3. The sub-reservoir at top right was enlarged relative to the infusion reservoir in LV2, to provide sufficient capacity for cryonics cases, although the system was never used for this purpose.*

All electronics were built into the lid of the primary Pelican case of LV3, while infusion and suction pumps were placed in their own module, consisting of box on a sliding tray that allowed access to the perfluorocarbon reservoir. These features were described and illustrated in an international patent application filed in 2008.[19]

In response to requests for a more automated version that would be appropriate for standby-stabilization personnel in cryonics cases, Platt started work on LV4 in 2009, but encountered problems relating to his extensive use of microcontrollers for functions including the display of prompts and error messages, the monitoring of all processes and temperatures, the saving of data at half-second intervals on flash memory, and the update of a realtime display of all experimental parameters. In 2010 Platt suggested passing the project back to Suspended Animation in Florida, and the prototype that he had developing was shipped to Florida later in the year (see Figure 12-12).

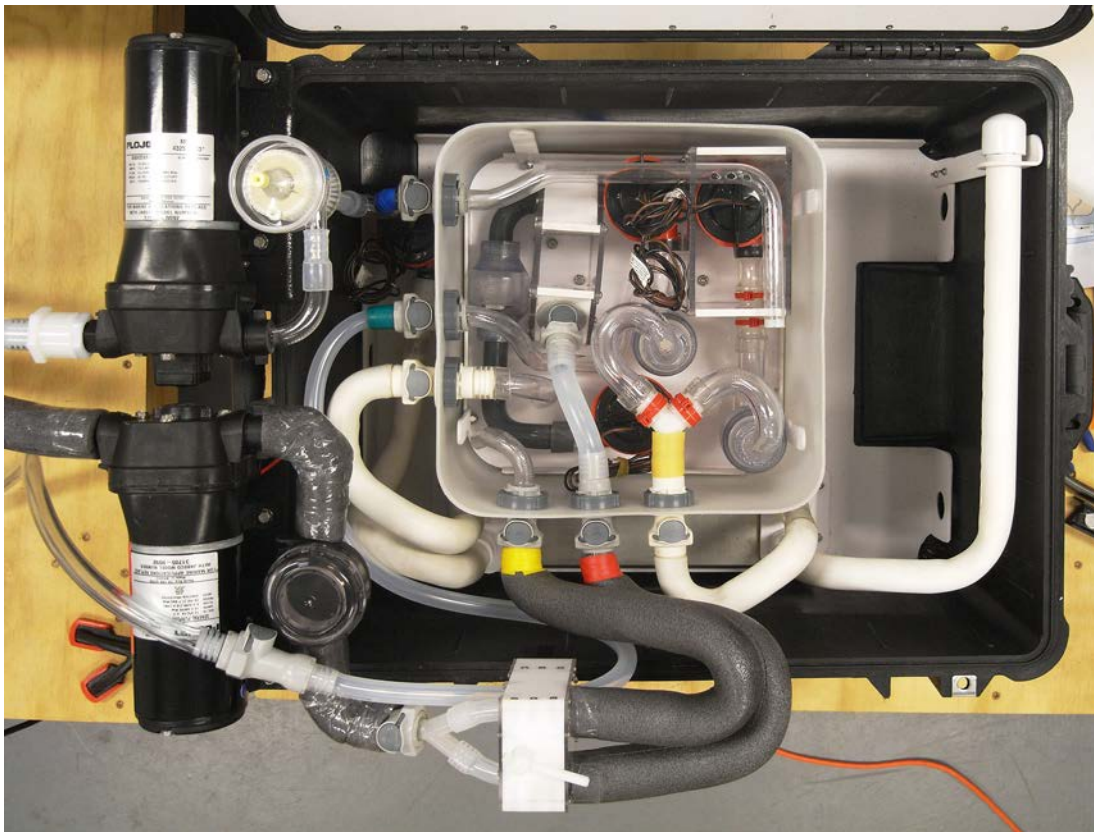

*Figure 12-12. For LV4, a larger perfluorocarbon reservoir accommodated two sub-reservoirs, one to measure infusion volume and a second to measure the returned volume in each cycle, so that a running average could be calculated, indicating whether liquid was accumulating in the lungs. The additional sub-reservoir entailed complications such as a need for check valves and other associated plumbing. To*

*allow maximum flow rates, custom-curved polyethylene and polyvinyl tubing were used instead of elbows and tees throughout. The two black, detachable pumps at left are the suction pump (top) and infusion pump (bottom), with a filter and a strainer alongside them. The empty space at right was to accommodate ice and water. Control electronics had not been installed when this picture was taken.*

Suspended Animation announced its intention to finish and test LV4 with new, LabView-based control electronics by May, 2011. This ambition was only partially fulfilled when an initial test was reported to have failed as a result of a valve malfunction. Later in the year, Suspended Animation reported informally that a subsequent test had been successful using a pig cadaver, with a claimed peak cooling rate of around 1 degree C per minute. No additional information was provided.

## **Design Features**

Some features remained constant throughout versions LV2 through LV4. In particular:

- All equipment was transportable in two model-1620 Pelican-brand cases. The primary case housed reservoirs and cooling pumps. The secondary case stored loose parts and tubing that had to be removed and assembled on-site in conjunction with the primary case, which was stacked above the secondary case during use.
- Ice was used as the cooling agent, because its high latent heat of fusion allows a relatively small weight to absorb large amounts of heat. Ice is readily available in any part of the country and is already required in stabilization procedures. Melting ice is incapable of reducing perfluorocarbon temperature below 0 degrees Celsius, which is considered an advantage, as lower temperatures would be potentially harmful to human tissue.

- Since the lungs are nonsterile, medical-grade peristaltic pumps were considered unnecessary. Peristaltic pumps are heavy, consume a lot of power, and are unavailable in 12-volt versions. A fundamental design goal was to have an all-12-volt system so that it would be fully portable and could be run, if necessary, from internal nickel-metal hydride batteries or an external car battery.
- Low-cost, small, high-volume centrifugal marine pumps were used to circulate perfluorocarbon and icewater through a heat exchanger. Larger diaphragm pumps were used for infusion and for suction in LV3 and LV4, since they are very robust and are able to run dry or pump a mixture of gas and liquid without damage. The diaphragm pumps are much heavier than the centrifugal pumps, but this was considered a necessary tradeoff.
- Three sets of nickel-metal hydride batteries were included, each rated to deliver up to 10 amp-hours, for a theoretical total of 30 amp-hours. The batteries proved capable of powering the system during operation for up to half an hour without a significant voltage drop. A medical-grade AC-DC converter was also included, capable of supplying almost 30 amps.
- In the interests of simplicity, the infusion volume was set by inserting plastic tabs into a small reservoir, to displace some of the liquid volume. This system proved more reliable than other volume-measurement strategies such as using flow sensors, weighing the reservoir, or using pressure-driven or ultrasonic level sensors.
- The equipment was designed for rapid assembly and for easy disassembly to allow cleaning.

Some of these features were upgraded in yet another version of the equipment, LV5, which was built by Charles Platt in response to a request for a system with simpler electronics that would be specifically suited for continuation of lab testing. This version is shown in Figure 12-13. It was

begun in February, 2011 and was completed and delivered in May, 2011. It featured an enlarged perfluorocarbon reservoir and a greatly simplified system for setting infusion volume, using a float-based level sensor mounted on a screw thread. A separate return reservoir was added for assessing volume suctioned from the lungs, and a drain valve allowed easier removal of water accumulating from melted ice. A manually operated pinch valve was included to switch between infusion and suction modes, and several fail-safes were added to simplify setup and reduce any risk of operator error. The control electronics in LV5 consist of a single 40-pin PIC microcontroller which could be reprogrammed via an external port. The system had sufficient capacity for human lungs, but was never used in cryonics cases.

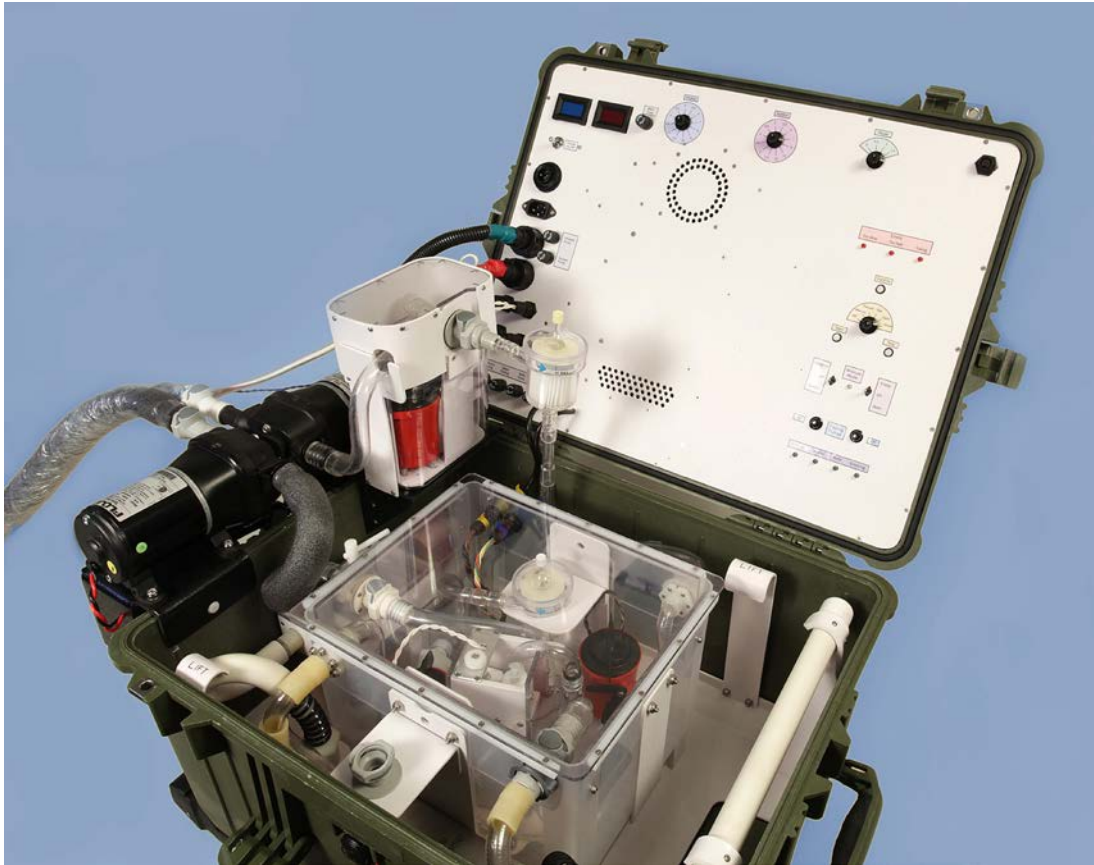

*Figure 12-13. LV5 was developed by Charles Platt in 2011 primarily for laboratory work. It uses a similar tubing configuration to that in LV4, with the addition of an elevated return reservoir (visible here with a red pump inside it), allowing simple visual assessment of liquid volume during suction cycles. The main perfluorocarbon reservoir was increased to the maximum size permitted by available space, and an icewater drain port was added (visible near the front of the Pelican container). Greatly simplified controls are visible at the right-hand side of the lid. Various connectors are visible on the left, allowing disconnection of all components for easy cleaning. A socket at top-right enabled the internal PIC microcontroller to be reprogrammed at any time. As this design was intended for laboratory use, there is no provision for battery power, although a socket at the left side of the lid allows connection of an external 12VDC source if one is available.*

## **Subsequent Developments**

In 2018, a comparison test was performed between LV5 and the most recent prototype developed independently at Suspended Animation, Inc. The comparison was informal, using different animal models at different laboratories, but was useful insofar as some problems became apparent with the SA version.

In 2019, because LV5 was now eight years old, and because there was renewed interest in using liquid ventilation in cryonics cases, Alcor contracted for new equipment, tentatively named LV5.1, to be developed jointly by Steve Graber in Scottsdale and Charles Platt at his own workshop in Northern Arizona. Graber was to build the hardware, while Platt would write the control software.

Later in 2019 it was decided that Graber would commission his own software for LV5.1 while Platt would develop hardware and software for a prototype referred to as LV5a. While LV5.1 was expected to be more innovative, LV5a would be as similar as possible to LV5, to minimize the risk of unexpected problems in development. At the time of writing, neither LV5.1 nor LV5a has been completed. Meanwhile, equipment at SA is undergoing more development.

While the concept of liquid ventilation is extremely easy to understand, building functional prototypes has been surprisingly elusive.

During eight years of testing LV5, the peak cooling rate of slightly more than 1 degree Celsius per minute has been consistent, although this rate inevitably levels off asymptotically as body temperature drops closer to the temperature of the perfluorocarbon. In experiments where animals were not sacrificed, almost all were subsequently revived and showed no signs of long-term injury. All experiments were performed under Department of Agriculture regulations which control procedures in animal laboratories, and general anesthesia was used in all cases.



## **Operation**

Operation of LV3 and LV5 has entailed the following steps. A similar setup procedure is likely in future versions, although several steps will be automated. Additional details are not known at this time.

- **Setup.** Unpack the secondary Pelican case. Attach removable wheels to the secondary case. Stack the primary case on top of the secondary case and use the provided clamps to hold the cases together. Attach the infusion pump, suction pump, and delivery tubing to the tubing assembly in the primary Pelican case. Select infusion time and suction time, for each cycle. In LV3: Insert volume displacement tabs in the infusion reservoir as needed to allow delivery of a selected volume in each cycle. In LV5: Turn a screw that moves a level sensor, to establish the preferred infusion volume.
- **Power.** Make sure that all power switches are off. Select a power source: Batteries, AC, or external 12VDC. Check that batteries are fully charged, if they are to be used.
- **Liquids.** Pour perfluorocarbon liquid into the perfluorocarbon reservoir. Load the icewater reservoir with water and ice. Distilled water is preferred, as it leaves no residues. Cube ice is preferred, as it is less liable to clog the plenum under the perfluorocarbon reservoir.
- **Cooling.** Make sure all pump switches are off before turning the power on. Start the cooling pumps that circulate water and perfluorocarbon through the heat exchanger.
- **Volume check.** After about 10 minutes, the perfluorocarbon liquid should be close to 0 degrees Celsius. Place a graduated cylinder under the ET tube, put the system in manual cycling mode, and run some test cycles to verify that the infusion pump delivers the selected volume within the selected time. Adjust the speed of the

infusion pump if necessary. (This step will almost certainly be eliminated in cryonics cases, where the control of infusion speed should be of less concern, as minor lung injury may be considered of secondary importance to the cooling rate.)

- Standby mode. Top off the perfluorocarbon reservoir if necessary, to compensate for accumulation of liquid in tubing. Run cooling pumps as needed. Add ice if needed. Remove accumulation of water from melted ice, if needed (a secondary pump is used for this, but a simpler method is likely in deployable equipment).
- Cycling. When signalled by the operator, begin infusion-suction cycling, either using automatic control or using manual control, as desired.
- Finishing. When the operator wishes to end the procedure, run the suction pump continuously to clear any residual perfluorocarbon liquid from the lungs.
- Cleanup. Turn power off, disconnect tubing, empty the reservoirs, and recover perfluorocarbon liquid if possible, for subsequent filtration and reuse.

## **Future Development**

During laboratory tests, the infusion volume has been established with reference to the body weight of the animal, because the body weight of lab animals used in the tests is roughly proportional with lung volume. Human patients will require a different methodology.

Kylstra's research in the early 1970s established some basic parameters for moving liquid into and out of the human lungs. He used a recognized medical procedure to infuse saline into one lung of a "healthy volunteer" while the other lung continued to breathe normally. The volunteer remained conscious during the procedure, receiving only a local anesthetic to numb his larynx and trachea, and in Kylstra's sardonic phrase, "did not experience intolerable sensations arising from the flow of saline."

Having determined that 500ml saline could be drained from the lung in a minimum time of 9.4 seconds, while infusion of the liquid under pressure could be faster, Kylstra concluded that the human lungs could be ventilated with liquid at a rate of 3 liters per minute. Liquid ventilation using diaphragm pumps for infusion and suction may achieve a rate slightly higher, but this remains a matter of conjecture until the procedure is used in human cryonics cases.

Several factors limit the infusion rate. A human trachea is of similar diameter to a canine trachea, even though the human lungs have a greater volume. An endotracheal tube must fit inside the trachea, and if liquid spurts from the tip of the tube with excessive force, it may cause mechanical injury to the lungs. The LV systems described in this chapter typically deliver 100 ml of liquid within about 2 seconds. We expect this rate to remain with little change in future versions.

## **Unresolved Issues**

A very significant issue in cryonics cases will be the challenge of applying chest compressions concurrently with liquid ventilation. During the majority of the experiments, cardiac arrest was not induced, and thus the issue of cardiopulmonary support was irrelevant. In the minority of experiments that did involve cardiac arrest, application of CPS was judged to be difficult and inappropriate, because the shape of the canine rib cage was incompatible with mechanical chest compressions.

However, Suspended Animation has reported that its first successful test of LV4, in conjunction with a pig cadaver, was performed in conjunction with chest compressions administered via an Autopulse system. Apparently, there was no conflict between the compressions and the infusions of chilled liquid. It is possible that liquid in the lungs may actually enhance the effectiveness of CPS by transmitting the compressive force more effectively. If necessary, liquid ventilation cycles could be synchronized with mechanical chest compressions to optimize cooling. Much work in this area remains to be done.

The concurrent, simultaneous use of a portable ice bath in conjunction with liquid ventilation should increase the cooling rate compared with liquid

ventilation used alone, although not by merely summing the rates that can be achieved by each method. Cooling will always be more effective initially, when the temperature difference between the coolant and the body temperature is greatest. Beyond this, we are unable to generalize in the absence of experimental data.

Liquid ventilation in its current mode will increase the expenses associated with deployment by requiring transportation of additional equipment and consumables, and additional personnel during stabilization.

LV1, LV2, LV3, and LV5 require an operator to add gas to the liquid flow by using a bag valve during each infusion cycle; LV4 was intended to use an automated system for this purpose. The relative merits of the two approaches have not been evaluated, but if a person is required to handle a bag valve, this task will occupy his whole attention.

Someone will be required to add ice when necessary, drain excess water from the icewater reservoir, and monitor the patient temperature, while supervising the operation of two heat exchanger pumps, infusion pump, suction pump, and two additional pumps associated with the reservoirs. Possibly this role can be intermittent, allowing the same person to perform other stabilization duties such as monitoring cardiopulmonary support.

The need for battery power in a liquid ventilation system remains a matter of debate. In almost any imaginable indoor scenario, AC power will be available. If liquid ventilation is used in a rented vehicle, personnel may use jumper cables to tap the vehicle's battery, although this will actually provide 14 volts or slightly more, and raises the risk of a loose connection resulting in a dramatic (possibly explosive) short circuit. Using batteries built into the liquid ventilation device would undoubtedly be safer, but they raise another problem: We have very little experience regarding the reactions of air transport security personnel when they view an x-ray of checked baggage containing multiple battery packs. Nickel-metal hydride batteries are not controlled by TSA regulations, but lithium-ion batteries are subject to limitations because of their greater potential fire hazard, and we have no way of knowing whether a typical baggage screener can tell the difference.

LV2 was flown successfully from Florida to California as checked baggage, with a large laminated card inside stating that the batteries were

nickel-metal hydride. LV4 was transported from Arizona to Florida via Federal Express. No other experience with long-distance transport of liquid ventilation equipment exists at this time.

The design for LV4 attempted to address the issue of battery transport by mounting the batteries in a separate, external box that could be shipped separately, while the AC-DC converter was mounted inside the lid of the primary Pelican case. Using this configuration, if the battery pack is embargoed, the rest of the equipment can still be used with an AC power source.

A final issue involves conflicting design requirements for laboratory/clinical use and for cryonics patients. The laboratory version of liquid ventilation equipment must be capable of short cycles and smaller volumes appropriate to animal testing, and must be elaborately instrumented for data capture. Researchers want to have manual control over many features, even though this adds to the complexity of the control panel. In the future, we may expect that a simplified cryonics-purposed liquid-ventilation device will be developed using presets with prompts and error messages. LV5.1 and LV5a are being designed with this in mind.

## **References**

1. Three boluses of perfluorocarbon, totalling more than 2 liters, were infused into the lungs of Alcor patient A-1876 by Mike Darwin on March 3rd, 2002 as described in “Fear, Anger, and Hope: The Cryopreservation of Alcor Member A-1876” by Charles Platt. *Cryonics* magazine, Vol. 23:1, 1st Quarter 2002.

2. “Rapid (0.5 degrees C/min) minimally invasive induction of hypothermia using cold perfluorochemical lung lavage in dogs” by Steven B. Harris, Michael G. Darwin, Sandra R. Russell, Joan M. O’Farrell, Mike Fletcher, and Brian Wowk, *Resuscitation* 50, August 2001, pp. 189-204.

3. See cooling curves in Figure 12-1 and Figure 12-2. Figure 12-1 was taken from international patent application WO2009042220 filed on September 26, 2008 by Critical Care Research et al, viewable at

[www.wipo.int/patentscope/search/en/detail.jsf?docId=WO2009042220](http://www.wipo.int/patentscope/search/en/detail.jsf?docId=WO2009042220) (accessed February 17, 2011). Figure 12-2 is from “The Cryopreservation of James Gallagher” by Mike Darwin, viewable at <http://www.alcor.org/Library/html/casereportC2150.htm> (accessed February 28, 2011), originally published in *CryoCare Report* number 6, January 1996. While a comparison between animal studies and a human case is of limited value, and while the curves in Figure 12-1 refer to a temperature range that is more limited than the curves in Figure 12-2, it seems safe to infer that (a) extracorporeal bypass can achieve a radically faster cooling rate than either liquid ventilation or surface cooling, and (b) liquid ventilation is almost certainly more powerful than surface cooling. The figures show that in the temperature range 9 to 11 degrees Celsius below normal body temperature, (probably representing actual temperatures from approximately 28 down to 26 degrees), using a canine model, the cooling rate was about six times as fast as the rate recorded for the human case between 23 to 20 degrees, all temperatures being measured tympanically

4. Fluorocarbon properties described in

<http://en.wikipedia.org/wiki/Fluorocarbon> (accessed February 17, 2011).

5. Chemical definitions found at

[http://en.wikipedia.org/wiki/Perfluorinated\\_compound](http://en.wikipedia.org/wiki/Perfluorinated_compound) (accessed February 17, 2011).

6. “Survival of Mammals Breathing Organic Liquids Equilibrated with Oxygen at Atmospheric Pressure” by Leland C. Clark, Jr. and Frank Gollan. *Science* 24, June 1966: Vol. 152 no. 3730.

7. Kylstra delivered a paper titled “Of Mice as Fish” at a medical conference, as described in “Artificial blood—an emergency air-lift?” by Dr. Michael Rose, in *New Scientist* magazine, November 27, 1980.

8. Overview of liquid breathing at

<http://www.medic8.com/medicines/Perflubron.html> (accessed February 17, 2011).

9. Scanned pages of the typewritten report are archived at

<http://www.dtic.mil/cgi-bin/GetTRDoc?AD=ADA037089&Location=U2&doc=GetTRDoc.pdf> (accessed February 16, 2011).

10. Research summarized at <http://archive.rubicon-foundation.org/4257> (accessed February 16, 2011).

11. Wikipedia entry on “The Abyss” at [http://en.wikipedia.org/wiki/The\\_Abyss](http://en.wikipedia.org/wiki/The_Abyss) (accessed February 16, 2011).

12. Interview with James Cameron at <http://www.ldsfilm.com/directors/Cameron.html> (accessed February 16, 2011).

13. “Liquid Ventilation of Preterm Baby” by Jay S. Greenspan , Marla R. Wolfson , S. David Rubenstein , and Thomas H. Shaffer in *The Lancet*, Volume 334, Issue 8671, November 4th, 1989.

14. “Partial Liquid Ventilation with Perflubron in Premature Infants with Severe Respiratory Distress Syndrome” by Leach et. al., *New England Journal of Medicine*, Volume 335, Number 11, September 12th, 1996.

15. Wikipedia entry on liquid breathing at [http://en.wikipedia.org/wiki/Liquid\\_breathing](http://en.wikipedia.org/wiki/Liquid_breathing) (accessed February 16, 2011).

16. This claim is made in U. S. Patent 6,694,977 filed by Federowicz et al., issued February 24th, 2004.

17. “Here, Breathe this Liquid!” by Charles Platt in *Discover* magazine, vol. 22, No. 10, first published 2001.

18. Darwin’s article was titled “A Bypass on the Way to Bypass” in *CryoCare Report*, number 7, April 1996.

19. U. S. Patent 5,927,273, issued in July, 1999.

20. This statement is made in U. S. Patent 6,694,977, issued in February, 2004.

21. The patent application for LV3 can be viewed at [www.wipo.int/patentscope/search/en/detail.jsf?docId=WO2009042220](http://www.wipo.int/patentscope/search/en/detail.jsf?docId=WO2009042220) (accessed February 17, 2011).

## 13. Medications

### Overview and Purpose

As a general rule, we assume that restoring circulation in a cryonics case will not be sufficient to maintain cellular viability, even in conjunction with hypothermia. (For information on the limits of CPS, consult the chapter on cardiopulmonary support.) We advocate administering medications to cryonics patients, after death has been pronounced, in pursuit of two primary goals:

1. To **promote circulation** by
  - a) improving blood flow
  - b) restoring volume.
2. To **inhibit processes which tend to cause cellular injury** in
  - a) the brain and
  - b) cells in general.

Note that *the first objective must be satisfied in order to achieve the second objective*. The circulatory system must remain open and unobstructed (in particular, free from blood clotting or sludging) to allow other medications to reach the brain. Even more important, the circulatory system must remain unobstructed to enable subsequent cryoprotective perfusion. If perfusion is not possible, all our efforts to avoid cellular injury may be nullified by massive ice damage when the patient is cryopreserved.

Medications therefore are not an “optional extra” to augment rapid cooling and cardiopulmonary support if the team can find time for them.



Whenever team members have access to the patient these two medications (as an absolute minimum) should be regarded as essential:

1. **Citrate**, an anticoagulant that prevents formation of blood clots.
2. **Heparin**, an anticoagulant that prevents formation of blood clots.

Administering medications is a greater challenge than inducing hypothermia or applying cardiopulmonary support. Training is required, and judgment must be exercised. Logistical issues and problems associated with preparation of medications will add to the challenge when the team attempts to administer the full recommended range.

## **Source and Validation**

Dr. Peter Safar, whose book *ABC of Resuscitation* popularized the concept of CPR in 1957, established the International Resuscitation Research Center (now the University of Pittsburgh Safar Center for Resuscitation Research) in 1979. In a series of experiments he demonstrated the effectiveness of high perfusion pressures and hemodilution, in conjunction with mild hypothermia, to restore cerebral circulation and revive animals after periods of ischemia following cardiac arrest.

In 1992, researchers Mike Darwin and Steven B. Harris MD ran a series of groundbreaking medications experiments to inhibit the toxic cascade of biochemical reactions that normally follows cardiac arrest. In some of their work they coupled this approach with the induction of mild hypothermia which Safar had pioneered. They were able to resuscitate dogs without measurable cognitive deficit after more than 14 minutes of arrest, with one animal recovering after more than 15 minutes.

The medications which we recommend for cryonics patients are those which were used in all three series of trials by Darwin and Harris. While the efficacy of each of these medications has not been individually established, we believe there is reasonable evidence that the full set of drugs enabled resuscitation without measurable cognitive deficit after a longer period of

arrest than has been achieved in any other known resuscitation research, using a canine model.

## **Prior History**

Additional medications have been used in cryonics cases in the past, but have been dropped from cryonics protocol. These include neuromuscular blocking/anti-shivering agents, calcium channel blockers, iron chelators, and cell membrane stabilizers. In 2002 cryonics researcher Mike Darwin proposed the protocol which we reproduce below for historical purposes and future research.

### **Proposed 2002 Alcor Stabilization Medications Protocol**

1. Vasopressin
2. Epinephrine
3. K-PEP Phosphoenol Pyruvate(PEP)
4. Propofol
5. Heparin,
6. Vital-Oxy
7. 4-Hydroxy TEMPO (TEMPOL)
8. Cyclotrol (Acetylsalicylic Acid and Ketorolac)
9. SMT (S-Methyl Isothiourea)
10. Dilazep
11. Acetyl-L-carnitine (ALCAR)
12. MIA (5 (N-Methyl-N-Isobutyl)-Amiloride
13. Lidocaine & Magnesium Chloride
14. Tacrolimus (Prograf)
15. Ethyl Pyruvate
16. FBP & DB-CAMP (d-Fructose 1.6-diphosphate & Dibutyryl Cyclic AMP)
17. Streptokinase
18. Trifluoperazine
19. Minocycline Hydrochloride
20. PARP-X (3-amino benzamide)
21. Vecuronium
22. Maalox

23. Tromethamine (THAM) OR Dextran-40 & THAM (Tromethamine)
24. Mannitol-Dextran-40 Injection
25. MicroThrx (Pluronic F-68)

## Current Full Stabilization Medications Protocol

We list the following medications in the sequence which we believe would be optimal during a cryonics case. The rationale for this sequence, and circumstances which may cause the team to deviate from it, are described below.

### *Small Volume Medications*

- 1. Propofol** (200 mg - fixed dosage). Propofol is a general anesthetic and is used for two reasons. The first reason is to reduce metabolism of the brain to reduce oxygen and glucose requirements, and the second reason is to prevent the theoretical possibility of recovery of awareness due to aggressive cardiopulmonary support.
- 2. Sodium Citrate** (10 grams for patients < 40 kg, 20 grams for patients > 40 kg). Citrate is an anticoagulant that prevents the formation of blood clots that can interfere with blood circulation and cryoprotective perfusion. By chelating calcium, it also prevents autoresuscitation of the heart. It is administered as a custom formulation of 20% w/v sodium citrate in water, packaged in 50 mL sterile vials.
- 3. Heparin** (50,000 IU – fixed dosage). Heparin is an anticoagulant that prevents the formation of blood clots that can interfere with blood circulation and cryoprotective perfusion. Heparin loses effectiveness at low pH (pH < 6.7), so control of pH is important during a cryonics stabilization. This is why other anticoagulants are also important.
- 4. Vasopressin** (40 IU – fixed dosage, second 40 IU dose concurrent with Vital-Oxy). Vasopressin is a *vasopressor* that is used to increase blood pressure during cardiopulmonary support. There is no need to

administer vasopressin if the patient's temperature is near or below +20 degrees C at time of administration as it is ineffective at cold temperatures.

- 5. Minocycline** (200 mg- fixed dosage dissolved in 10 mL saline). Minocycline is a broad spectrum bacteriostatic antibiotic and free radical scavenger with good tissue and brain penetration that possesses a broad variety of neuroprotective properties including inhibition of metalloproteinases, iNOS, PARP, mitochondrial cytochrome c release and, apoptosis.
- 6. SMT (S-methyl-isothiourea)** (400 mg – fixed dosage dissolved in 10 mL saline). SMT is a neuroprotectant (iNOS inhibitor) that is used to protect the brain from ischemic injury. SMT also raises blood pressure.

### *Large Volume Medications*

- 7 & 10. Decaglycerol/THAM** (2 x 200 ml- fixed dose). Decaglycerol is a glycerol polymer used to osmotically inhibit cerebral edema similar to mannitol. THAM is a buffer that is used to mitigate acidosis. Decaglycerol/THAM is administered as a custom formulation of 20% w/v decaglycerol and 4.5% w/v THAM (tromethamine) in water, packaged in 2x 200 ml sterile vials. The first 200 ml dose should be administered (I.V. push) after completion of small volume medications administration, and the second 200 ml dose is to be administered upon completion of administration of all other medications.
- 8. Vital-Oxy (formerly known as Oxynil)** (0.7 ml/kg up to 70 mL, dissolved in 150 mL saline). Vital-Oxy is a proprietary mixture of antioxidants and an anti-inflammatory agent developed by Critical Care Research, Inc., each mL of which contains 3.23 mg PBN (alpha Phenyl t-Butyl Nitron), 1.55 mg melatonin, 195 IU d-alpha-tocopherol (vitamin E), and 1.55 mg carprofen in an emulsion of Cremophor EL and 155 mg ethanol in water.

### *Fluids That Require Gastric Administration*

**9. Maalox** (250 ml – fixed dosage). Maalox is an antacid that is used to stabilize the pH of stomach contents to prevent erosion of the stomach wall by hydrochloric acid at low temperatures. Failure to prevent this can lead to contamination of the circulatory system with stomach contents and abdominal swelling during later perfusion.

### *Optional Medication*

**11. Hetastarch** (250 ml – fixed dosage). Hetastarch is a volume expander used to restore volume in dehydrated patients and increase cerebral perfusion during CPS.

### *Washout Medication*

**12. Streptokinase** (250,000 IU – fixed dosage dissolved in 5 to 10 mL normal saline). It's added to washout solution prior to remote blood washout or first cryoprotection flush in the OR).

## **The Importance of Patient Assessment**

Cryonics protocols should not be applied on a one-size-fits-all basis. Medications that are contraindicated for some patients can be a high priority for others. For example, rapid volume restoration with large volume medications is a high priority for patients who have become severely dehydrated. The choice of stabilization medications ideally requires some medical training or experience (see chapter on patient assessment).

## **Abbreviated Stabilization Medications Protocol**

In some cases it may not be possible or practical to administer the full set of medications. A full medication kit may not be available, or non-cryonics personnel may be administering medications. Medications may have to be obtained from a hospital pharmacy on an emergency basis.

Inability to administer the full medication protocol is usually due to absence of a cryonics standby team. It therefore usually coexists with inability to initiate prompt and sustained cardiopulmonary support (CPS) after cardiac arrest. In these cases personnel should focus on prompt cooling and rapid transport, but should still make every effort to administer the following medications in an effort to keep the circulatory system open, protect against free radical damage, prevent cerebral edema and abdominal swelling.

The minimal set of medications to be administered if stabilization procedures cannot begin promptly after cardiac arrest is called the Abbreviated Protocol or Abbreviated Set of Medications. It consists of:

- 1. Sodium Citrate (if available)** (10 grams for patients < 40 kg, 20 grams for patients > 40 kg).
- 2. Streptokinase** (250,000 IU – fixed dosage).
- 3. Heparin** (50,000 IU – fixed dosage).
- 4. Tempol** (if available) (5 g – fixed dosage - dissolved in 20 ml normal saline). Tempol is a low molecular weight superoxide scavenger used to mitigate ischemia-induced free radical damage. It is used only in the Abbreviated protocol.
- 5. Minocycline** (200 mg dose- fixed dosage).
- 6. Decaglycerol** (200 ml- fixed dosage).
- 7. Maalox** (250 ml –fixed dosage for gastric administration).
- 8. Streptokinase** (250,000 IU - fixed dosage - add to blood washout solution prior to remote blood washout or first cryoprotection flush in the OR).

Administration of these medications should be followed by at least ten minutes of chest compressions to distribute the medications, accompanied by surface cooling.

There is no firm time limit of clinical death beyond which the abbreviated set of medications should be administered instead of the full set.

However, as a general guide, the abbreviated set is indicated for patients who've suffered more than one hour of cardiac arrest.

## **Emergency Instructions for Stabilization**

For cases in which a cryonics standby team is not available, but local medical personnel are available to initiate basic stabilization procedures promptly after cardiac arrest, Alcor maintains a set of instructions called *Emergency Instructions for the Stabilization of Alcor Cryopreservation Patients*. The medications in those instructions are:

1. **Propofol** (2 mg/kg). Reduces metabolic demand.
2. **Streptokinase** (250,000 IU). Dissolves existing blood clots.
3. **Heparin** (420 IU/kg). To prevent the formation of new clots.
4. **Epinephrine** (0.2 mg/kg). A vasopressor.
5. **Gentamicin Sulfate** (1 mg/kg). Antibiotic.

Chest compressions and surface cooling are also to be performed as described above for the Abbreviated Stabilization Medications Protocol

## **Evolution of Dosages**

For most of cryonics history transport teams were trained to adjust dosages for medications based on patient body weight. These calculations were difficult for team members who lacked mathematical aptitude, and errors occurred even in training sessions where participants were not under the kind of time pressure that is typical during case work. Also, many team members had difficulty drawing volumes that were specified to a high degree of precision—less than 0.1 ml in some instances. The medication worksheet is reproduced in Figure 13-1 for historical reference.

**Medication Calculation Worksheet**

(Less than 30 minutes ischemic time)  
 (For more than 30 minutes, the order of the medications may change)  
 (Check with CryoTransport Manager for protocol)

Patient: \_\_\_\_\_  
 Alcor #: \_\_\_\_\_ Date: \_\_\_\_\_  
 Scribe: \_\_\_\_\_

Alcor Life Extension Foundation 

\* First Medications to Administer \*

Medication	Bdg	Notes	Package Contents	Package Concentration/mL	Dose (per kg)	A Calculated Dose / 1 kg (cc)	B Calculated Dose (cc)	Date: _____	Date: _____
						Time (Military) Meds Drawn	Time (Military) Meds Administered		
* Administer within 15 minutes of Protocols									
Dextran 1 (Promit)	1	[1]	20 mL	150mg	Give All	0.75	30		
Sodium Heparin	1	[2]	4 mL	10,000 units	420 Units	0.042			
Potassium Chloride	1	[2]	20 mL	2 mEq	1 mEq	0.5			
THAM	IV-1	[2]	500 mL of 0.3M	035 gm	Give All	12.5	500		
Diprivan (Propofol)	1	[3]	20 mL	10 mg	2 mg	0.2			
Streptokinase (Streptase)	1	[4]	5 mL	50,000U	Give All	0.13	5		
Vecuronium (or Norcuron)	1	[5]	10 mL	1 mg	0.1 mg	0.1			
Deferoxamine (Desferol)	1	[6]	500 mg/vial	500 mg/vial	Give All	0.2	8		
Vasopressin	2	[7]	1 mL	20 units	0.5 units	0.025			
Dextran 40 (Rheomacrodex) (I.V.)	IV-2	[2],[12]	500 mL	.1 gm	Give All	12.5	500		
Mannitol	IV-3	[2]	500 mL	.2 gm	2 gm	12.5	500		
Chlorpromazine (Thorazine)	2		10 mL	25 mg	3 mg	0.12			
Methylprednisolone (Solu-medrol)	2	[8]	8 mL	8 mL/vial (1 gm)	Give All	0.2	8		
Bactrim [AND]	2	[9]	10 mL/vial		Give All	0.25	10		
Oxantamycin Sulfate [OR]	2		2 mL	40 mg	1 mg	0.025			
Erythromycin	2	[10]	1 gm	50 mg	Give All	0.5	20		
Maalox	oral	[11]	250 mL	250	Give All	8.25	250		

B = A x Patient kg

The precalculated dosages in column A (and the tables) can only be used if the Package Concentrations are the same as those shown above. If not, then dosages must be re-calculated using the below formula:

Dosage (per kilogram) times Patient's Weight (in kilograms) divided by Package Concentration equals the volume to administer.

[1] Must be administered between 2 and 15 minutes before Dextran-40.  
 [2] Push total Volume  
 [3] Shake emulsion well before use. Use strict aseptic procedures - contains no preservatives.  
 [4] Reconstitute with 5 cc sodium chloride.  
 [5] Dry powder with diluent in package. Diluent is 10 cc of bacteriostatic water for injection. Use it all.  
 [6] Reconstitute with 2cc sterile water per / 500 mg vial. (4 vials needed)  
 [7] Vasopressin replaces Epinephrine as a far superior pressor.  
 [8] 8 cc Actovial (use all)  
 [9] Packaging concentration in each 10 cc vial should be 800 mg Sulfamethoxazole and 160 mg Trimethoprim  
 [10] Reconstitute with 20 cc sterile water / 1 g vial.  
 [11] Administer through gastric tube, using 50 cc catheter tip syringe.  
 [12] Of them all, this absolutely MUST be administered within 15 minutes of Dextran 1.

Alternate Method to Calculate Dosage [8]

Multiply Patient Weight in kg by the calculated dose for a 100kg kilogram patient or the number in [8] times cc to administer. If [8] differs from column A, already filled in with a pre-determined dosage that fits all patients.

1 mL = 1 cc  
 1 cc = 1.2 mg  
 1 g = 1000 mg

Figure 13-1. A medications dosage calculation worksheet formerly used by Alcor. The complexity of the calculations made it unpopular with standby personnel.

In March, 2003, while working for Alcor, Charles Platt initiated a dialogue with Harris that led to a simplification of dosages, using a lookup table instead of calculations. This lookup table is now obsolete but may still be found in some medication kits that were distributed regionally at that time.

Harris also eliminated the following medications, either because the need for them was debatable or because they had not been used in all three series of the Darwin/Harris animal trials: Deferoxamine, Chlorpromazine, methylprednisolone (Solu-medrol), Sulfamethoxazole (Bactrim), and erythromycin. Any team members discovering these medications should mark them DO NOT USE and set them aside.

After further consultation, first with Platt and then with de Wolf, Harris recommended that dosage calculations could be eliminated entirely for almost all the remaining drugs. Most of them are not toxic in large doses, and since a rigorous and proven rationale for converting dosages from the canine experiments to dosages for human patients had never been developed, Harris



felt that it was unnecessary and potentially misleading to pretend that a precise dose existed.

During the years since 2003, other smaller, incremental changes have been made to the medication protocol recommended by Harris and used at Alcor and at Suspended Animation. In particular, the method for preparing Vital-Oxy has changed significantly resulting in better emulsions. (Note that in old training documents, it was referred to as Oxynil. Its name was changed when another drug was marketed under that name, for use in conventional medicine. Any vials containing “Oxynil” should be marked DO NOT USE and should be set aside.)

The medication protocol may continue to evolve, especially in response to practical experience gained during cases.

## **Packing of Medications**

The large number of medications used in cryonics requires a well thought out organization of the many vials, bottles, IV bags, and supplies to facilitate methodical preparation and execution of the medications protocol. In 2003 Alcor introduced the use of Thomas Packs to organize and transport the medications. The reasoning was that medical professionals would feel more familiar and therefore more comfortable with the use of these packs. Figure 13-2 shows a Thomas pack opened for access, and figure 13-3 shows its separate small-meds pouch.



*Figure 13-2. A Thomas Pack of the type commonly used by emergency medical personnel. Equipment is in the main pack while medications are in the separate yellow pouch shown at top-right.*



*Figure 13-3. Medications in the separate pouch that is part of a Thomas Pack. High-volume medications in cryonics cases cannot fit in the pack, and the syringes for administering the meds must be packed separately. For these and other reasons, the Thomas Pack system was eventually discontinued in cryonics cases.*

A major perceived problem associated with Thomas Packs is that the system offers few visual clues as to where medications are located, and their sequence of administration is unclear. Another limitation is that the medications are separated from the supplies to draw and administer them.

To remedy these issues Suspended Animation adopted a medium-sized Pelican case to store its medications and supplies. It is shown in Figure 13-4.



*Figure 13-4. The system developed by Suspended Animation to store medications and supplies. Each transparent tube packed in the lid could be pulled out, and the caps were easily removed. Appropriate syringes were included in each tube. High-volume medications were packed in foam dividers beneath the white tray, which was intended to rest across the rails of a portable ice bath.*

The guiding principles of the Suspended Animation system were:

- 1.** All medications and supplies should be easily visible after opening the case.
- 2.** The small-volume medications were placed in plastic numbered tubes in chronological order of administration.
- 3.** The large volume medications were likewise numbered, while being located in the bottom of the container.
- 4.** Medications and the supplies to prepare and to administer them were combined.

Suspended Animation also introduced a simplified dosage chart, on two laminated pages (shown in Figure 13-5 and Figure 13-6).

 **Suspended Animation**

## LOW VOLUME MEDICATIONS

	Medication	Dosage	Details
<b>1</b>	<b>Propofol</b> Liquid (Diprivan)	<b>200 mg</b> Fixed dosage	1 vial (20 ml at 10 mg/ml). Draw the full amount into a 30 ml syringe. Administer the full amount.
<b>2</b>	<b>Streptase</b> Powder (streptokinase)	<b>250,000 units</b> Fixed dosage	1 vial (250,000 units). Add 5 ml saline or sterile water immediately before use. Shake to dissolve. Draw all of solution into syringe, administer entire amount through filter.
<b>3</b>	<b>Heparin</b> Liquid (sodium heparin)	<b>100,000 units</b> Fixed dosage	3 vials (4 ml at 10,000 units/ml each). Draw all of the first two vials and half of the third vial into a 10 ml syringe. Administer this amount. Discard the remainder.
<b>4</b>	<b>Aspegic</b> Powder (Injectable aspirin)	<b>200 mg (1 ml)</b> Fixed dosage	1 vial (1 g). Add 5 ml sterile water immediately before use. Shake until dissolved. Draw only 1 ml into 5 ml syringe, using a filter. Administer only 1 ml. Discard the rest.
<b>5</b>	<b>Vasopressin</b> Liquid	<b>200 units total</b> Fixed dosage	10 vials (1 ml at 20 units/ml each). Draw all vials into a 10 ml syringe. Administer only 5 ml. Wait 15 minutes, then use remaining 5 ml (until patient temperature is below 25 Celsius.)
<b>6</b>	<b>Epinephrine</b> Liquid	<b>30 mg total</b> Fixed dosage	1 vial (30 ml at 1 mg/ml). Draw entire vial into 30 ml syringe. Administer 1 ml every 3 minutes until none left, or until patient temperature falls to 25 Celsius.
<b>7</b>	<b>SMT</b> Powder	<b>400 mg</b> Fixed dosage Backup dose supplied	1 vial (400 mg) +1 backup. Add 9 ml saline 2 days (max) before use. Shake to dissolve. Administer entire amount using filter. If solution is unused after 2 days, discard it and use backup.
<b>8</b>	<b>Citrate-Dextrose</b> Liquid	<b>100 ml</b> Fixed dosage Backup dose supplied	2 vials (50 ml) +2 backup. Use 100 ml to dissolve NiKy powder 2 days (max) before use. Shake to dissolve. See below.
<b>9</b>	<b>NiKy</b> Powder Keep frozen	<b>1.5 grams</b> Fixed dosage Backup dose supplied	1 vial (1.5 grams) +1 backup. After dissolving with 100 ml Citrate-Dextrose, administer entire amount using filter. If solution is unused after 2 days, discard it and use backup.
<b>10</b>	<b>Ketorolac</b> Liquid	<b>7.5 to 15 mg</b> Dosage must be adjusted for patient weight	1 vial (2 ml at 30 mg/ml). <b>For patients 100 kg or more: draw 0.5 ml into 3 ml syringe and use this amount. For patients 50 kg or more: draw and use only 0.25 ml.</b>
<b>11</b>	<b>Gentamicin</b> Liquid	<b>80 mg</b> Fixed dosage	1 vial (2 ml at 40 mg/ml). Draw the full amount into a 3 ml syringe. Administer the full amount.

Administer low-volume medications in numerical order.  
Start high-volume medications simultaneously if possible (see other side of this sheet).  
**After using each medication, mark it with an X and put it back in the meds container for verification.**  
Save used syringe filters in a ZipLoc bag  
For meds that require filter sterilization, use a new needle for administration.

Figure 13-5. A laminated page developed at Suspended Animation to guide personnel in administering medications.

 **Suspended Animation**

## HIGH VOLUME MEDICATIONS

	Medication	Dosage	Details
<b>H1</b>	<b>Vital-Oxy</b> Liquid Concentrate (proprietary emulsion)	<b>80 ml or less</b> Dosage must be adjusted for patient weight	1 bottle (80 ml). Inject 150 ml warmed saline into bottle. Mix. Use heating pad to warm if necessary. Administer via IV line. <b>For patients under 100 kg, reduce dosage in ratio to weight.</b>
The following three fluids should be piggybacked on to 1 liter of saline solution.			
<b>H2</b>	<b>Dextran 40</b> Liquid	<b>250 ml</b> Fixed dosage	1 bottle (500 ml of 10% solution). Use only HALF of the supplied amount. Administer 250 ml via IV line.
<b>H3</b>	<b>THAM</b> Liquid	<b>250 ml</b> Fixed dosage	1 bottle (250 ml of 0.6M solution). Administer the whole quantity via IV line.
<b>H4</b>	<b>Mannitol</b> Liquid	<b>100 grams</b> Fixed dosage Backup dose supplied	1 IV bag (500 ml of 20% solution/100 grams) + 1 backup. Administer the whole quantity via IV line. Mannitol crystallizes readily; to liquify use a warming pad or immerse in hot water.
The following medication is to be administered orally.			
<b>H5</b>	<b>Maalox</b> Liquid	<b>250 ml</b> Fixed dosage	1 bottle (355 ml). Use about two-thirds of the bottle. Administer to stomach via gastric tube or Combitube (white #2 tube) in esophagus, NOT the trachea.

**Start low-volume medications first (see other side of this sheet).  
However, Vital-Oxy is a very high-priority medication.**

Try to administer high-volume meds at the same time as low-volume meds if possible.  
Also try to administer high-volume meds simultaneously with each other.

**After using each medication, mark it with an X  
and put it back in the meds container for verification.**

Maintain the IV during transport to blood washout and setup for washout.

This card was revised July 6, 2006

*Figure 13-6. Continuation of the medications instructions developed at Suspended Animation. The high-volume meds were labeled H1, H2, etc. to match the instruction page.*

In 2008 Alcor introduced its own new packaging system, combining the medications and supplies in vacuum sealed bags with identifying cards.

## **Preparation of Medications**

Medications in cryonics are mostly supplied in (sterile) vials, while fluids come in either bottles or bags. Bottles are often in used for drugs that have been prepared by the cryonics organization itself or an associated research company.

Team members are likely to encounter drugs that come from three different sources:

1. Medical supply houses
2. Chemical supply houses
3. Compounded in-house

The last two kinds of medications can present formidable challenges in the field because they require additional steps before administration. What follows is a brief treatment of medications that are currently used in cryonics and require special attention.

### *Medications Requiring Reconstitution*

Some medications cannot be stored as a liquid without degradation or decomposition occurring. These medications are stored in powder form and must be dissolved in a liquid prior to use. This process is known as reconstitution.

In the current recommended protocol, the following medications require reconstitution:

Streptokinase

SMT

TEMPOL



A reference sheet or laminated card will be provided by the cryonics organization, specifying the solvent that should be used to reconstitute each drug. Sterile water or normal saline (sodium chloride solution) may be used.

The most important thing to remember about medications that need reconstitution is that they often need to be used within hours of preparing them. They cannot be returned to the inventory of the cryonics organization if they are unused after reconstitution. For this reason it is important to acquire some knowledge and experience in predicting when cardiac arrest is likely. If medications are drawn and the patient lives for a number of days, these medications usually have to be discarded and replaced with fresh ones. For this reason some cryonics organizations include duplicate vials of the same medication.

**Reconstitution Procedure.** First draw the right volume of the appropriate solvent into a syringe. Then insert the needle through the rubber insert in the cap of the vial containing the powdered medication, and inject the solvent into the vial. Remove the syringe and gently shake the vial until the powder dissolves completely. It is very important to visually check whether the resulting solution is clear, because undissolved particles will present problems when the medication will be administered and may also clog small vessels of the patient.

Some medications must be filtered before or during administration. A syringe filter is used for this purpose. A medication that has not completely dissolved can present problems during filtration, sometimes requiring “brute force” to get the solution through the filter. Team members should inspect medications that have been reconstituted a number of times prior to administration to ensure that the chemical has not come out of the solution and collects at the bottom of the vial.

### *Filtration*

Chemicals prepared and packed at cryonics facilities under non-sterile conditions must be filtered with a 0.2 micron filter prior to or during administration. A syringe filter will remove foreign particles. The most important point that needs to be stressed is that the needle that was used to draw the reconstituted solution into the syringe must be discarded and

replaced with a fresh needle before filtration, to insure that the medication will not be pushed through the filter into the same (contaminated) needle again.

In a number of cryonics cases, team members have experienced difficulty forcing solutions through syringe filters, and have had to exert extreme pressure. This problem may indicate that reconstitution of the medication was not successful and the solution still contained particles that did not dissolve. In general, if extreme plunger pressures are required to achieve flow, team members should discard the filter because such pressures can expose them and the patient to risk. The integrity of the filter may also suffer at such pressures.

### *Viscosity*

Some medications that come in glass bottles are so “thick” that rapid administration using a drip is not practical. Vital-Oxy and Decaglycerol/THAM are examples. In such cases team members can draw the contents into a number of large syringes and give them as a bolus.

## **Multiple Doses**

Ideally, multiple smaller doses of vasopressin should be administered on as-needed basis to maintain blood pressure during CPS to achieve target metrics, such as 5% end tidal CO<sub>2</sub>. However, for simplicity in the current protocol, the doses of vasopressin have been reduced to two large doses. The last vasopressin dose is to be administered immediately before or during Vital-Oxy administration because the cremaphor emulsifier of Vital-Oxy is known to reduce blood pressure.

Although multiple doses can be given from the same syringe, a persistent mistake in training sessions and actual cases has been to administer the complete amount in a syringe in the “heat of the moment”. Therefore, each dose should be prepared separately in its own individual syringe.

## **Storage**

All medications can be refrigerated. Because medications should be administered as rapidly as possible, they should be prepared, reconstituted, and drawn into syringes before they are needed. As indicated above, this will require good judgment in predicting the time when the patient will go into cardiac arrest. Team members should seek advice on this topic from palliative care givers (hospice nurses) and medical professionals such as critical care doctors and nurses.

As a quality control measure, all syringes must be labeled and numbered so that information about which medications have been administered (or not administered) will be available to team members and writers of case reports. In addition, each label should be marked with a permanent marker after the medication has been administered.

## **Intravenous Access in Cryonics Patients**

Although medications can be administered directly through the skin or even through the nose, most medications benefit from being injected into a vein of the patient. Medications can also be injected into an artery, but this entails some risk and should be attempted only by skilled medical professionals.

Two fundamental points are especially important:

- 1.** Administration of multiple medications requires the placement of a secure catheter.
- 2.** Prompt restoration of blood flow and keeping the circulatory system open is necessary for effective administration of drugs.

If only one drug will be administered to the patient (usually heparin), it may be injected into a vein. Raising the vein will be challenging unless cardiopulmonary support is being applied concurrently, to create some blood pressure.

Where more than one drug will be used, an intravenous catheter must be placed to secure patent access to the vein, eliminating the need to find a new

injection site for each successive medication. The catheter can also be connected to an intravenous line to deliver fluids to the patient.

As for the need for blood circulation, this may seem obvious, yet cases in cryonics have been reported where a series of medications were injected into a vein without any attempt to induce circulation. Administration of medications without circulation will not confer benefits on the patient and may even be detrimental when many different medications are administered without flow. Restarting blood circulation by manual or mechanical chest compressions will not only facilitate timely distribution of the medications through the circulatory system, it may also help in locating and placing a catheter in a patient.

One of the biggest challenges in cryonics cases has been to obtain venous access to place a catheter. Case histories provide ample evidence that even people with medical qualifications and extensive experience may have difficulty achieving intravenous access in a cryonics patient. In some cases this has resulted in no administration of medications at all. In others, some surgical access to the patient's vessels (a "cut-down") was required.

The three most important reasons why obtaining venous access in cryonics patients is difficult are:

- 1. Dehydration.** Most patients that present for cryonics procedures have become severely dehydrated during the terminal phase of their illness. A cryonics organization may encourage care givers to keep the patient hydrated up until the point of clinical death, but re-hydrating the patient after pronouncement will require venous access in itself.
- 2. No cardiopulmonary support.** Until blood circulation has been restored, the lack of blood flow in vessels will make it harder to locate, palpate and access them. Manual or mechanical chest compressions should be administered.
- 3. Fragile Vessels.** Most cryonics patient are very old and suffer from advanced fragility of the vessels. In such cases, medical professionals with extensive experience will have the best chance of placing a catheter successfully and securely.

## **Prioritizing Stabilization Interventions**

Unless a secure catheter or port is already in place at the time of legal death, the stabilization team will need to make a decision whether to place a catheter prior to moving the patient to the icebath or after the patient has been moved to the icebath. Because even short delays between cardiac arrest and restoring circulation can contribute to the so called “no-reflow” phenomenon (see the chapter on cardiopulmonary support), it is extremely important to start mechanical CPS in the icebath as fast as possible. Another reason to delay placing the catheter until the patient has been placed in the icebath is to avoid dislodging the catheter upon moving the patient.

Often rapid interventions such as placing a catheter or starting a drip produce unexpected challenges and complications. If this happens, even longer delays before vigorous mechanical cardiopulmonary support can be started are guaranteed. To avoid this scenario, priority must be given to cardiopulmonary support.

## **Sequence of Medications**

Administering a full set of cryonics medications can take more than one hour, if we include the time required for fluids. This raises issues about the priority in which the medications are administered and the advantages of simultaneous administration.

The recommended sequence of medications represents a compromise between importance and practicality. On a practical basis we suggest using the low-volume medications first, to maximize the chance of administering as many as possible. Within the low-volume group, we place the most essential drugs at the top of the list: Propofol, to remove any chance that vigorous resuscitation will restore awareness in the patient, and citrate and heparin, to reduce the risk of blood clots obstructing the vascular system.

A strong case can be made to broaden these three essential medications to include one drug that increases the patient’s blood pressure to improve blood flow to the brain immediately after pronouncement of legal death (when the patient is not cold yet). Rapid administration of drugs to increase blood flow

to the brain during chest compressions not only confers direct protection to the brain but also enhances cooling of the brain by improving circulation. Such drugs are called vasopressors. Epinephrine and vasopressin are examples.

One limitation of vasopressors is that they are rapidly eliminated by the body (even after pronouncement of the patient) and therefore require intermittent administration. As the patient gets colder, the need for intermittent administration diminishes.

Intermittent administration of medications requires anticipation and methodical planning. Multiple doses should not be given from the same syringe as this raises the risk of someone inadvertently giving the whole dose at once. A series of syringes should be prepared, each containing one dose to be delivered at pre-determined intervals.

Although we believe that the patient will benefit from intermittent administration of vasopressors, the intervals at which dosages should be repeated are not based on exact science. It is therefore important for the team leader (or scribe) to ensure that team members will not become too distracted by watching the stopwatch. One could indicator of the decreasing efficiency of the vasoactive medications is to monitor end tidal CO<sub>2</sub> values (see the chapter on monitoring).

If team members are sufficiently well trained and well organized, we recommend that they should try to save time by giving large-volume fluids at the same time as the small-volume medications.

This conveys two benefits:

1. Simultaneous administration increases the chance that important large-volume fluids will be given to the patient. This is especially important in the case of Vital-Oxy, which should be given the highest priority.
2. Small-volume medications will benefit from being “followed” by fluids in the line.

Skilled medical professionals may even be able to deliver multiple fluids at the same time, but case simulations and actual cases have demonstrated that the procedure to “piggy back” different fluids can cause confusion and error.

Unless someone is skilled in this technique, we do not recommend it for cryonics stabilization procedures.

Correct administration of medications is treated in mainstream nursing and emergency medicine texts, but we have to emphasize, here, that when small-volume medications are given through the IV line, the line above the point of administration needs to be clamped off (by squeezing or an actual clamp) to prevent the medication going up the line instead of down the line.

## **Intraosseous Infusion**

An important alternative to conventional intravenous administration of medications is to introduce them into the marrow of the bone, which is in continuity with venous circulation. This procedure is known as “intraosseous infusion,” and eliminates the need to locate, palpate and puncture a vein by injecting a needle. It has become increasingly popular in emergency medicine (in the armed forces, in particular).

Since the mid-2000s intraosseous infusion has also been used in cryonics. There are a number of technologies to place a catheter into the bone marrow ranging from using a simple intraosseous needle to equipment that can “drill” or “shoot” the needle into the bone.

Although intraosseous access to the circulatory system can be obtained in numerous places in the body, the most common locations are the breastbone (sternum) and the tibia (the large bone below the knee). The procedure requires some skill and training, but is not plagued with as many challenges as conventional intravenous access, and can be established within one minute by experienced team members.

The most basic method of intraosseous infusion is the use of an intraosseous needle (Jamshidi bone marrow needle). Needle size can range from 14G to 18G. Unless the small size of a patient mandates a smaller bore needle, the larger bore needles are recommended in cryonics because they allow for faster administration of the large volume medications. The preferred location for intraosseous access is the proximal tibia. After identifying and disinfecting the landmark, the needle is pushed through the periosteum into the bone using a screwing motion. This is illustrated in Figure 13-7.

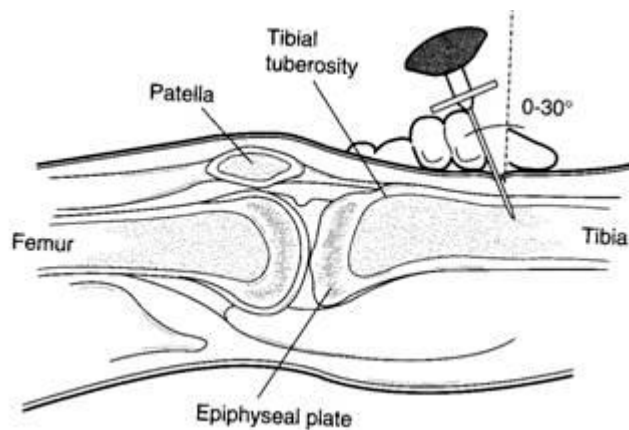

Figure 13-7. Inserting an intraosseus needle.

The indicator that one is into the bone is when resistance disappears and the needle “gives.” At that point the needle stylet can be withdrawn and the needle is connected to the IV line to administer fluids and medications. Manual intraosseous needles are (relatively) small, inexpensive, and allow for repeated attempts when initial attempts fail. One disadvantage is the manual strength that is required to insert the needle. To address this challenge, and to make this technology more feasible for emergency settings, specific intraosseous infusion devices have been developed by medical equipment makers.

The first of these devices is called the BIG (Bone Injection Gun), which uses a spring loaded needle to obtain access to the bone marrow. The second of these devices is called the EZ-IO. The EZ-IO uses a lithium battery driven power driver to insert the needle into the bone marrow. Both devices eliminate the need to manually insert the needle with a lot of pressure. This enables the user to focus exclusively on accurate placement of the needle without the risk of causing trauma to the patient or himself.

A third option is the F.A.S.T. 1. Unlike the other two devices, the F.A.S.T. 1 is designed to be used on the sternum of the patient and still requires manual force to insert the intraosseous needle.

In cryonics both the FAST and EZ-IO have been chosen for case work, but the EZ-IO seems likely to become the method of choice because it



eliminates the challenges of using blunt force to place a needle and eliminates scenarios where placement of the F.A.S.T. 1 competes with chest compressions and ice placement.

Intraosseous infusion can be used at multiple locations simultaneously. This creates an opportunity to give small- and large-volume medications at the same time or can be used when two large volume medications compete for priority.

The only serious contra-indications for the use of intraosseous infusion in cryonics patients would be the presence of bone fractures, and any disease that increases the risk of a fracture during placement of the needle. If intraosseous infusion is attempted under these circumstances, fluids can collect in a confined space without entering the patient's circulatory system. When placement is contra-indicated in a certain area (the left tibia), another location can be chosen (the right tibia or the sternum).

## **Endotracheal Drug Administration**

Some drugs can also be administered via the lungs of the patient. The typical scenario where endotracheal drug administration can be advantageous is when a patient already has a patent airway in place prior to pronouncement, and gaining access to the circulatory system is not possible or desirable. The drawback of this method is that only a small number of medications can be administered in this fashion. Be careful to follow these guidelines for endotracheal drug administration:

1. It can be used only for the vasoactive agents epinephrine and vasopressin.
2. The recommended dose is 2.5 times the intravenous or intraosseous dose.
3. The medication must be diluted in 10 ml of saline or sterile water. Sterile water is preferred because it increases drug absorption.
4. Endotracheal drug administration must never be used for large volume medications.

Important: If a Combitube is used for placing an airway, endotracheal drug administration cannot be used unless in the rare event where the Combitube has been placed in the trachea with the patient being ventilated through the white tube.

## **Pressure Infusion**

*This procedure should not be attempted by inexperienced team members!*

Pressure infusion allows a large volume to be administered in a shorter period of time by applying pressure to the bag in which the fluid is maintained. Pressure infusion should be used in cases where the patient is so dehydrated that a rapid inflow of fluids is required to restore blood pressure. It can also be used to reduce the total amount of administration time of all the large volume medications. Two methods are possible:

1. Use an appropriate pressure infusion cuff (similar to a blood pressure cuff) or a designated pressure infusion pump.
2. Under desperate circumstances, squeeze the bag containing the fluid. This is generally undesirable, since it raises the risk of applying too much pressure or admitting air into the IV line.

When a pressure infusion cuff is used, the IV bag should be placed in the pocket and secured on the IV pole. After the IV bag is secured in the pressure cuff the bulb is squeezed to increase the pressure and thus the rate of the drip. This procedure should only be attempted if someone is designated to monitor the remaining volume in the bag and maintenance of a secure IV line and catheter.

Pressure infusion is also possible in unvented bottles by removing the filter covering the vent port and using a 20 or 50 mL syringe to inject air into the bottle to speed up the pace of the drip. This procedure should not be used by inexperienced team members and without consultation of the person overseeing the case. Failure to closely monitor and stop an infusion accelerated by pressurized air can cause venous air embolism.

## **Maalox Administration**

*Administration of Maalox should be discussed, prepared and planned by the team in advance and should not be treated as a last minute decision!*

Although administration of the antacid Maalox (which is a suspension of aluminum hydroxide and magnesium hydroxide) has been a core component of cryonics stabilization protocol for many years, this fluid has routinely been omitted in recent cryonics cases for a number of reasons. Unlike the other medications and fluids, Maalox needs to be infused directly into the stomach. The challenge this presents often leads to omission of Maalox administration altogether. Another reason for routine omission of Maalox administration is limited knowledge about its objective and importance. Audrey U. Smith reviewed the importance of neutralizing hydrochloric acid in the stomach during circulatory arrest and hypothermia in her work on reviving mammals from subzero temperatures. These, and similar, observations guided the decision to use cimetidine to inhibit gastric hydrochloric acid production, and Maalox to neutralize acidic stomach contents in cryonics and the Cryovita/Alcor canine washout experiments.

Although Maalox is the last item on the medications list, it can be administered promptly after pronouncement because IV access is not necessary. Maalox can be given either using the Combitube or using a gastric tube. A major advantage of the Combitube is that administration of Maalox can be combined with giving ventilations through the same device.

If no ET tube is in place after pronouncement of death, a Combitube can be placed to ventilate the patient and administer Maalox. It's of crucial importance to understand the way the Combitube works to avoid ventilating the stomach or administering Maalox down the trachea of the patient.

The Combitube works on the principle that the "natural" angle to intubate a patient is to insert the tube in the esophagus. The blue (number #1) tube is closed at the end but perforated to allow flow into the trachea. If the Combitube is placed in the esophagus, the patient needs to be ventilated using this tube and Maalox can be administered through the open ended white (number #2) tube. Placement and ventilation of the Combitube can be

validated by observing bilateral chest rise or end tidal CO<sub>2</sub> measurements. Correct placement of a Combitube is shown in Figure 13-8.

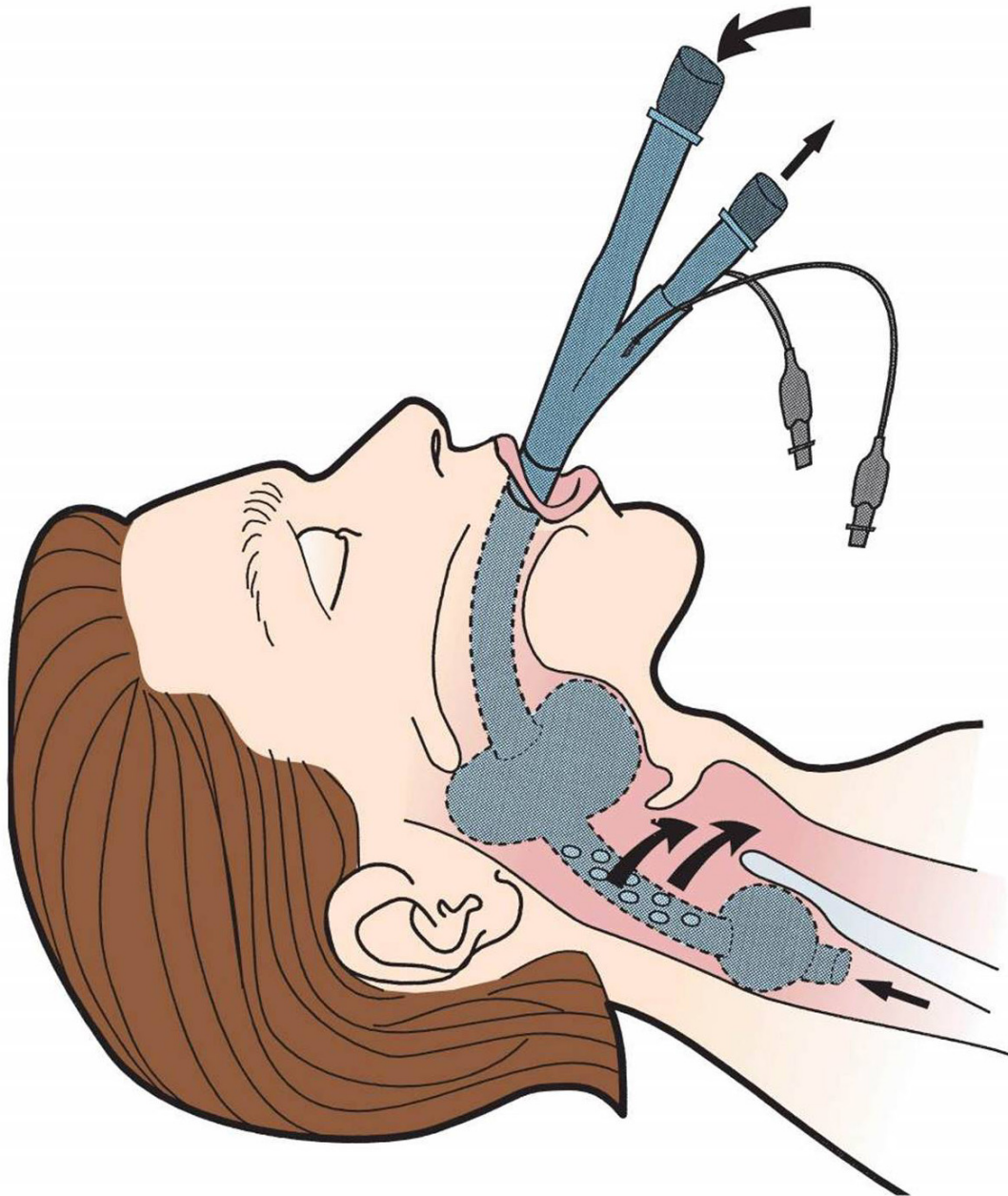

Figure 13-8. Placement of the dual-lumen Combitube. Note the perforations through which ventilation takes place while the tube is anchored in the esophagus. From *Trauma, seventh edition*, by Toschlog, Sagraves, and Rotondo.

Although the Combitube is routinely placed in the esophagus, sometimes it is placed directly in the trachea. If this is the case, the patient needs to be ventilated through the white tube. If the Combitube is placed in the trachea, the Combitube cannot be used to administer Maalox because the tube with the open end has direct access to the lungs!

*Warning: If you start ventilating through the blue tube this does not necessarily mean that Maalox administration is safe. What you really need to know is whether the Combitube is in the esophagus or in the trachea. Do not administer Maalox before validating tube placement and validating ventilations. If the Combitube is in the trachea, Maalox administration is not possible using the Combitube.*

If a team member has validated placement of the Combitube in the esophagus, the team leader can authorize administration of Maalox through the white (number #2) lumen. The correct volume (250 ml) can be administered by pulling out the plunger of the furnished irrigation syringe, inserting the tip of the syringe in the white (number #2) tube, carefully pouring down the volume in the syringe, and pushing the plunger to “inject” it down the esophagus. This procedure needs to be repeated a number of times to deliver the complete 250 ml. An alternative for the irrigation syringe is to use the large 140 ml syringe that comes with the gastric tube discussed below.

If the patient has already an endotracheal tube in place, or endotracheal intubation has already been established by the team, Maalox needs to be administered using a gastric tube. A gastric tube enables direct access to the stomach to deliver fluids to a patient. A tube and appropriate syringe are shown in Figure 13-9.



*Figure 13-9. Syringe and gastric tube suitable for infusing Maalox.*

Placement of a gastric tube in a cryonics patient is not routine and may present a significant challenge. A few basic guidelines must be followed:

Do not attempt to place a gastric tube before other means of administering Maalox (such as the Combitube) have been ruled out.

Do not attempt to place a gastric tube without authorization of the team leader.

Do not risk dislodging the endotracheal tube by placing the gastric tube. If the gastric tube needs to be placed, delay administration of Maalox until all the other medications and fluids have been administered and personnel is available to monitor the airway and ventilations during gastric tube placement.

The gastric tube is a stiff large-bore tube that should be manipulated through the esophagus into the stomach. It is important to lubricate the complete tube prior to inserting it. If gastric tube placement is successful, the

Maalox can be administered by connecting the adapter on the proximal end of the gastric tube to the top of the syringe.

Note: Normal gastric intubation requires a gag reflex for ease of placement, so it's not known whether this technique will work in the cryonics patient. If there are indications that placement doesn't work, do not force it. Discuss the issue with the team leader and consultants.

Note: If there is an endotracheal tube in place (or the Combitube is in the trachea) another alternative would be to quickly extubate the patient and place the Combitube in the esophagus. This method requires careful coordination between team leader and team members to minimize interruption of ventilations. Do not pull out the existing tube without deflating the cuff (or cuffs in case of the Combitube)!

**REMEMBER:** Administration of Maalox should be discussed, prepared and planned by the team in advance and should not be treated as a last minute decision.

It is important to remember that Maalox is not just important during CPS. The existing evidence for the benefits of Maalox use is to prevent cold-induced gastrointestinal complications. Even at low temperatures, cells still require energy and prolonged patient transport times (~ 24 hours) will produce (cold) ischemia. To counter the effects of ischemia on the stomach, administration of Maalox is recommended regardless of the quality of stabilization prior to transport.

## **Legal, Ethical, and Practical Issues**

In Chapter 4 we dealt extensively with general legal and ethical issues relating to cryonics. In this section we will mention only those issues relating to medication of a patient.

The success of a case often hinges on a good relationship between standby/stabilization team members and medically qualified caregivers. In some instances, helpful nursing staff have allowed or enabled team members to begin giving medications immediately after pronouncement. In other

instances, hostile caregivers or administrators have prohibited any such intervention.

The relationship between team members and medical staff can be damaged permanently and irrevocably if medically qualified people have any reason to suspect that cryonicists may violate these absolute prohibitions:

Never violate instructions from the primary care physician or others who are under his authority.

Never administer any medications (or medical treatment of any other kind) prior to pronouncement of the patient.

Never give any cause for the misconception that cryonicists may attempt to hasten the death of the patient.

Since secrecy can erode trust, the Team Leader should initiate an explanation of the purpose of all the medications used to stabilize a patient after pronouncement. Without such an explanation, hospice or hospital personnel may automatically assume that the medications brought in by the cryonicists are for use while the patient is still alive. The idea of using medications after death may not occur to them, and may seem irrational.

Team members should emphasize that no DEA-Scheduled drugs are used. After the reorganization of stabilization medications that occurred in 2003, scheduled drugs have been strictly eliminated from stabilization kits. In particular, propofol has been substituted for sodium pentobarbital. If anyone asks questions about drugs in the kit which the team members are unable to answer, they should put the person in contact with the medical advisor who is advising the cryonics organization that is managing the case.

If hospital or hospice staff still refuse to allow administration of medications, team members should pursue other concessions, such as a guarantee of very prompt pronouncement that will enable rapid removal of the patient from the facility. The team can also request permission to commence cooling and cardiopulmonary support on-site, even if medications have been prohibited.

Since hospitals and hospices generally try to respect the wishes of a patient, the Team Leader should emphasize that this is his objective too. He



should be able to present documents showing that the patient had a sincere desire for rapid intervention after cardiac arrest (assuming the patient is unable to make this claim himself, and no one with medical power of attorney is available to speak on his behalf).

The threat of legal action to force an institution to recognize the desire of the patient for post-arrest medication should be used only as an absolute last resort, and only after consultation with the president or CEO of the cryonics organization that is managing the case.

In almost all instances that we know of, openness, politeness, and a respectful attitude have achieved good results, while confrontation has tended to make a difficult situation worse.

## **14. Monitoring**

This section concerns monitoring and data collection during cryonics stabilization procedures. Monitoring of the patient during stabilization will be broadly defined, and we will include the collection of data during deployment and standby.

Data collection during other phases of human cryopreservation is discussed in other sections, as follows:

Blood gas analysis	Section 15
Blood washout and substitution	Section 16
Cryoprotection	Section 18
Cryogenic cooling	Section 19

### **Feedback from Cryonics Procedures**

One of the biggest myths in cryonics is that only the future can tell us how good our procedures were. It is of course correct that the objective of cryonics is to revive and restore patients in good health. In this strict sense, only the future will tell us whether this ultimate goal has been achieved. But when we look at the actual cryonics procedures that are employed to place a patient in cryostasis, we will find that many of these procedures have specific objectives that allow for data collection and evaluation today.

For example, one of the objectives of cardiopulmonary support is to generate sufficient blood flow to the brain to support metabolic demand. One of the objectives of blood washout is to increase the cooling rate of the patient. The objective of cryoprotection is to protect the patient against ice formation. During each of these procedures, data can be collected to assess how well the

objectives have been achieved. This will also allow us to compare protocols and cases and identify areas for improvement.

Another important objective of data collection and monitoring is to identify strengths and weaknesses in standby teams and personnel.

In an ideal situation the objective of a cryonics organization to meet these objectives would be treated in the same way as the objective of keeping a patient alive in mainstream medicine. Unfortunately, there is a real difference between keeping a patient alive and viable and checking off a number of quantitative goals on a data collection sheet during a cryonics case. If a hospital would be incompetent and understaffed in a case, the potential result could be the death of the patient, which would trigger a host of emotional, legal, and financial responses. In cryonics there is not a distinct point at which such a response would be triggered. Cryonics organizations and their members do not even necessarily agree on how much effort should be expended to prevent any additional damage after pronouncement of legal death.

All cryonics patients will need some treatment in the future to address the cause of death, and this requirement is often invoked to argue that the same technologies should be able to repair any additional damage that is sustained during cryopreservation. The perspective at Alcor, however, has been to resist such reasoning and to aim for minimizing the additional damage that the patient incurs during cryonics procedures. In short, the objective is to sustain viability of the brain as far downstream of our procedures as possible, and when this objective can no longer be achieved, to secure the best ultrastructural preservation of the brain as possible. It is this perspective that informs the discussion of data collection and monitoring in the remainder of this chapter.

## **Data Collection**

Data collection starts when a member joins Alcor. On the application form, the member can enter physiological and health information that will be filed with cryopreservation contracts. Alcor encourages members to update this information if circumstances change. The information can not only assist

Alcor in estimating the risk of terminal illness of a member, but can also be used to inform deployment, stabilization, and cryopreservation decisions.

The real collection of data, however, typically starts when Alcor is notified of the pending death of a member. At this point staff will start gathering up-to-date information about the patient's health condition (a topic that is discussed in more detail in Section 7) to make standby and deployment decisions.

It is routine in cryonics that staff members dealing with the case keep a written record of the case as it develops. In circumstances where written notes are not possible, a voice recorder is a good option. The collection of data continues during the case either by people making notes, or through the use of (monitoring) equipment. After completion of the case all the data are organized and used to create a case report.

## **Voice Recorders**

The use of voice recording is a powerful tool for data collection in a cryonics case. Their advantage in cryonics is that they allow team members to report about the case while performing other important tasks such as standby procedures or surgery. During procedures such as surgery or intubation, only the person who is doing the work has a good look at what is going on, and voice recording allows these procedures to be recorded. In some cases it is not even necessary that the person dictates directly to the equipment; even the recording of a conversation during a procedure (such as the priming of the washout circuit or surgery) can provide valuable information about the procedure.

Most modern voice recording equipment also provides timestamps. This will tell the writer of a case report not only what is going on but when it happened. This is particularly important when there is an omission in the data collection sheets, and to note crucial points during a case (cardiac arrest, start of cardiopulmonary support, administration of the first stabilization medication, and so on.) Reading the events and timestamps allows the case report writer to construct a timeline of the case. It is important to recognize here that team members should make a deliberate effort to synchronize their

watches and (recording) equipment to allow for a smooth reconstructing of the important events in a case.

Until quite recently voice recording required purchase and maintenance of specialized voice recorders that utilized special software to download the recordings to a computer. With the widespread adoption of cell phones, there is less need for such specialized equipment, and a phone can of course store video as well as audio.

Note, however, that a headset is necessary to record audio when the person is using both hands in a procedure. While many phones enable a headset to be connected via a USB cable, a suitable app may be needed to enable the phone to recognize the headset. Also, voice-actuated recording is helpful so that anyone transcribing audio subsequently will not have to listen to long periods of dead space. For these reasons, a separate, dedicated voice recorder still has some advantages.

Either way, there are few excuses to avoid audio and video recording in case work today. The lack of it shrouds cryonics in an aura of secrecy that damages credibility and makes it difficult to factually defend actions of cryonics team members if that should be necessary.

## **Temperature Monitoring**

Cryonics is all about time and temperature. We would like to stabilize the patient at cryogenic temperatures without ice formation as quickly as possible after pronouncement of legal death. At the end of a case we should be able to graph the temperature of the patient as a function of time. Unlike other procedures, such as ventilation or cryoprotective perfusion, temperature data can be collected from the start of procedures until the patient is placed into liquid nitrogen (or intermediate temperature storage). Therefore, in a well-run cryonics case we should expect to see temperature data for all parts of the procedures, including transport.

This does not mean that the collection of temperature data is equally important throughout all parts of the procedure. While there is usually no good excuse to omit gathering temperature data in any part of our procedures, collecting temperature data during the initial stages of stabilization is of

crucial importance. As soon as the patient goes into circulatory arrest (and sometimes before that point) energy depletion of the brain will set off a cascade of events culminating in injury and perfusion impairment in the brain. The most potent strategy to counter this injury is to cool the patient as quickly as possible. Temperature monitoring is the only credible means to assess how successful initial induction of hypothermia has been, and how different (external) cooling methods compare.

The need to collect temperature throughout all parts of procedures requires that we log the temperature automatically instead of taking intermittent readings from the patient. During stabilization and transport this means the use of a portable temperature logging device, and during cryoprotective perfusion and low temperature cooling temperature probes in the patient will communicate data directly to a computer.

Another important requirement of good temperature monitoring is the ability to measure temperature at different locations in the patient. This can be achieved by using two temperature loggers, but the preferred solution in cryonics is to use a logger that receives inputs from two separate temperature probes. For a considerable period, the temperature logger of choice at Alcor has been the Digi-Sense DualLogR (SOP for cryonics use is available here: <http://www.alcor.org/Library/pdfs/dualogr.pdf> ). The DualLogR is no longer available but has been replaced by the Oakton Temp-300 Dual-Input Datalogging Thermocouple Thermometer that retains the same functionalities and also allows direct uploading of the data to a USB port on a computer. See Figure 14-1.



*Figure 14-1. The Oakton Temp-300 Dual-Input Datalogging Thermocouple Thermometer.*

These devices not only permit time-stamped temperature logging of two temperature probes but also have the ability to change the logging interval, so they can be used in situations where the logging interval needs to be relaxed to prevent running into the maximum number of data points, such as during transport of the patient.

While the newer Oakton dual-input temperature logger seems more robust in terms of water damage, one of the challenges during cryonics stabilizations has been to prevent temperature logger malfunction as a result of immersion in the portable ice bath. For this reason some cryonics organizations have used water-proof cases to protect the logger against mechanical shock and fluids. Pelican brand cases are waterproof, and very small sizes are available, appropriate for most loggers.

There are a number of reasons for wanting to log temperatures measurements in different parts of the body. One reason is redundancy. If one temperature probe gets dislodged during movement of the patient, or transport,

temperature logging will not be interrupted. Over the years there have been multiple cases without reliable temperature data during a part of the procedure because a temperature logger did not work or the probe was disconnected. Such scenarios will be greatly reduced if multiple temperature probes are placed. Another reason for placing multiple probes is to ensure the collection of reliable data. If one temperature probe is incorrectly placed and not inserted far enough the result will be that the probe will just be measuring the temperature of ambient air or ice water. In both cases, temperature data will not be reliable.

Yet another reason for using multiple temperature probes is to identify (transient) regional temperature differences. For example, rectal temperatures have often been observed to lag core brain temperature. Finally, in procedures such as blood substitution we do not only need to log the temperature of the patient but monitor the temperature of the arterial and venous fluid as well. In such circumstances the use of multiple dual-input logging devices is recommended.

Temperature data are also useful for comparing the efficacy of different methods of cooling. Most of our knowledge about the relative effectiveness of different cooling methods in cryonics has been obtained from comparing case temperature data. For example, temperature data collection has allowed Alcor to rank internal and external cooling methods from least effective to most effective as follows:

1. External cooling with ice bags (slowest)
2. External cooling in ice bath with CPS (cardiopulmonary support by chest compressions)
3. External cooling in ice bath with CPS and with recirculating water ice (squid)
4. Cyclic lung lavage with CPS (liquid ventilation) under development
5. Extracorporeal cooling (fastest)

A comparison of different cooling methods in cryonics is shown in Figure 14-2. Because this figure shows cooling curves from three patients of



different body weight, the results are not strictly comparable, but they do suggest that an extracorporeal cooling device, colloquially known as a “squid,” should be used in an ice bath. See Section 11, which discusses the induction of hypothermia.

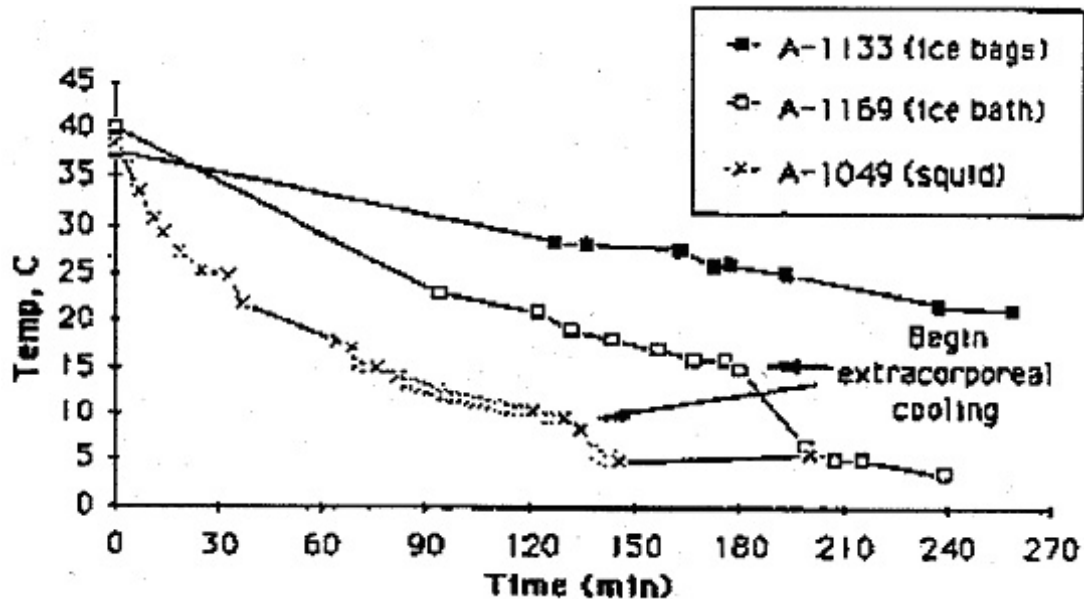

Figure 14-2. Cooling of patients in three Alcor cases. See text for caveats regarding this data.

While some people have a good intuitive grip at the efficacy of different cooling methods, collecting the actual data can still be revealing. For example, throughout the history of cryonics there have been multiple debates about the values of adding a submersible pump to circulate the ice water in the ice bath. But as this graph shows, the substantial gains in cooling rates are definitely worth the additional effort. Achieving rapid cooling rates at the start of stabilization procedures is one of the most effective tools we have to protect the patient against warm ischemia and associated perfusion impairment during washout and cryoprotective perfusion.

## **Cardiopulmonary Support Monitoring**

The effectiveness of cardiopulmonary support (CPS) can be monitored regardless of which device is used. The most straightforward indication of restoration of circulation is to observe the patient's response to chest compressions and ventilations. Visual signs of restoration of perfusion include change of skin color and capillary refill times. Because a patient in cardiac arrest or poor circulation will look pale, CPS should return a pink color to the skin (look at inner eyelids, lips, and nail beds). Circulation can also be assessed by pressing and releasing the nail bed and counting the seconds for a pink color to return. Normal capillary refill time should be two seconds or less. However, capillary refill checks are typically done in pediatric patients, and their value for adults in clinical situations is controversial. Another straightforward sign of perfusion is to check the patient's skin temperature and condition simply by touching the forehead.

As the last example indicates, many of these traditional measurements are only of limited use in cryonics. Whereas a paramedic would consider a cool and clammy skin a sign of shock, in a cryonics patient we would hope to see a cool and "wet" forehead as this would indicate rapid induction of hypothermia and use of circulating ice water. A pale skin color is not necessarily a bad thing either because this might be the result of cooling and vasoactive medications (such as vasopressin) instead of inadequate perfusion. One solution to these problems would be to leave a portion of one extremity (like a part of the arm) unexposed to ice or water but this may present a logistical challenge and would still not counter the effects of vasoactive medications on peripheral blood flow. And even if such visual methods of assessing perfusion would work, the nature of this information would be qualitative, not quantitative in nature, and generally insufficient to refine or change procedures.

There are many different techniques for giving chest compressions and some techniques generate better cardiac output than others. In cryonics, CPS techniques range from manual chest compressions by hand to mechanical high impulse active compression-decompression CPS (HI-ACD CPS). See Section 9 for more details.

Conventional cardiopulmonary resuscitation (CPR) typically generates only one-third to one-quarter of normal cardiac output, even when vigorously applied. This is generally not sufficient to meet cerebral energy demands and should only be used as a bridge to defibrillation (in conventional medicine) or blood washout (in cryonics).

In cryonics patients cardiac output may be further compromised because many patients are atherosclerotic and/or have gone through a prolonged period of shock or multiple organ failure prior to pronouncement of legal death. In ideal cases, securing cerebral viability may still be feasible, however, if aggressive multimodal techniques are used. An example of such a scenario would be a case where the team is able to intervene immediately after pronouncement of legal death; circulation and ventilations are promptly restored using a mechanical device capable of active compression-decompression CPS; a respiratory impedance valve is attached to the airway to improve venous return to the heart; blood pressure is supported by vasopressin and/or epinephrine; and rapid administration of neuroprotective medications and induction hypothermia are started to protect the brain until blood substitution or cryoprotection is possible.

Normal Mean Arterial Pressure (MAP) is between 70 and 110 millimeters of mercury (mmHg). Lower MAPs of ~ 50 to 60 and higher are still associated with cerebral viability, but manual CPR is rarely higher than 40 mmHg. Although measuring MAP (or even normal blood pressure) is generally too invasive or impractical during stabilization of the patient, some indirect measurements of the effectiveness of CPS can be obtained by pulse oximetry, end tidal CO<sub>2</sub> measurements, and blood sampling.

## **Pulse Oximetry**

A pulse oximeter can be attached to a finger or earlobe to monitor pulse rate and oxygen saturation. See Figure 14-3. It is usually included in a cryonics standby kit as an option to monitor the patient prior to pronouncement, although permission must be obtained from any attending medical personnel, as explained in Section 7.



*Figure 14-3. A pulse oximeter opens on a spring-loaded hinge so that it can accept a finger tip to assess oxygenation of the blood.*

A pulse oximeter displays the percentage of arterial hemoglobin in the blood. Normal saturation readings at or near sea level range between 95% to 100%. A lower reading is acceptable at significantly higher altitude, such as 5,000 feet or above.

Using a pulse oximeter after pronouncement and during CPS is controversial, as readings may be erratic. It is also recognized that pulse oximetry readings become less reliable when the readings drop below 70%.

Pulse oximetry is also not a good measure of ventilation. This situation may be aggravated in cryonics as a result of aggressive vasopressor use and hypothermia. Another important caveat in the use of pulse oximetry is that it does not reflect insufficient hemoglobin in the blood (anemia). As a

consequence, oxygen saturation levels may look good but there is not enough oxygen to meet the metabolic demands of the patient. Still, in light of the ease of taking pulse oximetry readings, pulse oximetry may be worthwhile to look for trends or serious deficiencies in ventilation.

## **End Tidal CO<sub>2</sub> Monitoring**

The best non-invasive indicator of cardiac output and oxygenation during cardiopulmonary support (CPS) is end tidal carbon dioxide (ETCO<sub>2</sub>). ETCO<sub>2</sub> is the partial pressure of carbon dioxide (CO<sub>2</sub>) at the end of an exhaled breath. Until recently, cryonics standby kits were equipped with disposable colorimetric ETCO<sub>2</sub> detectors of the colorimetric type shown in Figure 14-4. This detector can be attached directly to the endotracheal tube, or any other kind of compatible secure airway, to monitor exhalations. Some limitations of disposable ETCO<sub>2</sub> detectors of this type are that they are not quantitative, not continuous, hard to read in the dark, and can give false readings.



*Figure 14-4 Easy Cap disposable ETCO<sub>2</sub> detector, which changes color to provide an approximate indication of the partial pressure of carbon dioxide gas at the end of each exhalation.*

In 2006 this situation changed when Alcor started using the CO<sub>2</sub>SMO (pronounced “cosmo”), a sophisticated monitoring device that can give a complete respiratory profile of the patient. The CO<sub>2</sub>SMO does capnography, pulse oximetry, and gives a comprehensive non-invasive, continuous respiratory profile. It operates by connecting a respiratory sensor to the patient's ventilation circuit while also connecting the pulse oximeter sensor to a finger or earlobe. See Figure 14-5.



Figure 14-5. The CO2SMO system, showing the unit, its display, and associated cabling.

Although this represents the state of the art in respiratory monitoring, its cost, size, and complexity will limit routine use of this equipment in remote cases.

In August 2007 Suspended Animation, Inc. added the Capnocheck to its standby equipment. This was similar in size to the older colorimetric disposable detectors but gave quantitative and digital readings for ETCO<sub>2</sub> and respiratory rates using infrared technology. ETCO<sub>2</sub> readings were shown in mmHg and the respiratory rate was given in breaths per minute. This device is no longer being manufactured, but the Capnocheck II, shown in Figure 14-6, is larger and uses a sensor connected by a wire to the display.



Figure 14-6. The Capnocheck II.

ETCO<sub>2</sub> can be used to evaluate the effectiveness of chest compressions and as a predictor of outcome during cardiopulmonary resuscitation. Studies have found that patients with restoration of spontaneous circulation (ROSC) have higher ETCO<sub>2</sub> levels than patients that could not be resuscitated (levels <10 mmHg). Normal ETCO<sub>2</sub> levels are between 35 and 45 mmHg. Because numeric readings of ETCO<sub>2</sub> have rarely been obtained and analyzed in cryonics, and knowledge about what ETCO<sub>2</sub> levels to expect and not to expect are currently unknown. At this point in time, meticulous note taking of ETCO<sub>2</sub> levels during CPS is essential to generate more data about the efficacy of cardiopulmonary support.

Another important use of ETCO<sub>2</sub> monitoring is that it can be used to validate correct placement of the endotracheal tube (or Combitube). If the endotracheal tube has been placed in the esophagus, or has become dislodged,



we expect to see negligible ETCO<sub>2</sub> readings. Another issue that needs to be taken into account is the effect of stabilization medications on ETCO<sub>2</sub>. For example, administration of the vasopressor epinephrine will decrease ETCO<sub>2</sub> readings although cerebral blood flow may be improved.

One concern that has been raised about the use of ETCO<sub>2</sub> monitoring is that it adds another adjunct to the endotracheal tube. If the ETCO<sub>2</sub> detector is the only adjunct used during a case there should not be a problem, but adding the ETCO<sub>2</sub> detector to an inspiratory impedance threshold valve (such as the ResQPOD Circulatory Enhancer) can create an unstable “tower” of adjuncts on the endotracheal tube (or any kind of ventilation tube). Because both adjuncts are important in cryonics stabilization protocol, this remains an ongoing challenge.

Some cryonics technologies such as liquid ventilation appear to be incompatible with ETCO<sub>2</sub> monitoring altogether. One way around such challenges is to consider measuring oxygen saturation directly in the brain. ETCO<sub>2</sub> monitoring does not give direct information on how well the brain of a cryonics patient is being perfused, but there are now technologies that can specifically address this question.

## **Cerebral Oximetry**

As a rule of thumb one should expect evidence of effective ventilation (such as good ETCO<sub>2</sub> values) to indicate that the enough oxygen and other energy substrates are delivered to the brain. However, there are a number of reasons why apparent adequate ventilation may fail to meet the metabolic needs of the brain.

The most likely obstacle to good cerebral oxygenation in cryonics is inadequate cerebral perfusion. As discussed above, conventional chest compressions often fall short of generating enough blood flow to the brain to meet metabolic demand. Mechanical chest compression devices such as the LUCAS may do a better and consistent job, but even the efficacy of such methods may decline during a case.

Another reason why delivery of oxygen to the brain can falls short of need is the presence or development of cerebral edema. If intracranial pressure

exceeds arterial pressure, the brain will not be perfused, even if chest compressions are vigorous enough to meet metabolic demand under normal circumstances. Even if cerebral edema does not prevent blood flow to the brain, blood flow can still be limited in specific areas of the brain as a result of compression of (micro) vessels. Other factors that can limit blood flow to the brain include vasoconstriction, blood coagulation, red cell aggregation, brain tumors and ischemia-induced perfusion impairment.

Oxygenation of the brain can be directly measured by taking blood samples from a catheter in the jugular vein. This approach is invasive, labor-intensive, requires advanced medical skill, and is not compatible with the field logistics that characterize a typical cryonics stabilization case.

A recent non-invasive technology that can be used to measure oxygenation of the brain directly is cerebral oximetry. Cerebral oximeters measure transcutaneous oxygenation of the frontal cerebral cortex by exploiting the property of hemoglobin to absorb light. The blood that is measured for oxygen is estimated to be 70% venous and 30% arterial. Because the frontal cerebral cortex has high metabolic demands and limited oxygen reserve, oxygen deficiency in this area can indicate poor delivery of oxygen to the brain as a whole. Measurements of cerebral oxygenations are displayed as a regional oxygen saturation value called rSO<sub>2</sub>.

The dominant commercial cerebral oximeter on the market today is the Somanetics INVOS system. The INVOS can be used on adult, pediatric, infant, and neonatal patients and can assist patient management in a range of medical treatments ranging from cardiac surgery to emergency out-of-hospital situations. It can operate down to 16 degrees Celsius, which permits collecting cerebral oxygenation data in cryonics during stabilization and the initial stages of blood substitution. The INVOS is available as a two-channel or four-channel device, and sensors are available for all typical patient sizes. The four-channel version allows for simultaneous monitoring of cerebral and somatic oxygenation, which can alert the cryonics team to peripheral / cerebral oxygenation imbalances and cerebral perfusion problems.



*Figure 14-7. Four-channel version of the INVOS 5100C Cerebral/Somatic Oximeter showing adult-size and child-size sensors.*

Collecting data on cardiopulmonary support and ventilation has historically been a challenge during cryonics stabilization procedures. As discussed in Section 10, the only quantitative information that we have about the efficacy of these procedures has been obtained in a few selected cases in which blood gases were collected and analyzed. During the cryopreservation of patient A-1049 Alcor sought to overcome this challenge by using the CO2SMO, but the device was not used to guide treatment in the field and was never deployed again. Cerebral oximetry may be the first new technology that could be routinely used during cryonics stabilization procedures.

The INVOS system consists of a monitor, pre-amplifier, disposable sensors (2 or 4) and sensor cables. The disposable sensors are attached to both sides of the patient's forehead, and should be protected from (extreme) moisture. The monitor measures 24 cm (height) 29 cm (width) 19 cm (depth) and weighs around 5 kg. Since the system would be used in conjunction with a portable ice bath, and a separate portable roll stand would be inconvenient during transport, a method to secure the device to the ice bath would have to be established. Alternatively, the INVOS could be used exclusively in the Alcor transport vehicle (and OR).

There is only limited clinical evidence for using the INVOS (or similar devices) during resuscitation and/or hypothermic procedures, but its theoretical advantage is that it could help a cryonics organization assist in answering one of the most fundamental questions involving cryonics stabilization: is the brain kept viable by contemporary medical criteria? With hospital or hospice approval, the device can also be used to monitor the condition of the brain during the agonal phase, which would be useful in establishing a baseline for stabilization procedures.

## **Bispectral Index**

An even more robust measurement of the condition of the brain could be achieved by conducting EEG measurements on the brain of the patient during transport. Obviously, such an approach would only be feasible in cases in which the patient has been pronounced legally dead by cardiopulmonary criteria and the standby team can start procedures promptly after pronouncement. In cases where the patient is pronounced by brain dead criteria, or where stabilization procedures start after a prolonged period of ischemia, EEG measurements are not likely to produce meaningful information.

Electroencephalography (EEG) is the recording of electrical activity along the scalp by measuring the ionic activity of neurons. Whereas EEG recordings in small (research) animals typically require time-consuming invasive surgical procedures, the procedure in humans can be conducted non-invasively by securing electrodes to the scalp of the patient, either individually or by using a cap or net in which the electrodes are embedded. The use of EEG in cardiopulmonary resuscitation is uncommon because the urgency surrounding CPS does not allow for placing the electrodes on the scalp and obtaining the readings. Another limitation of using EEG for out-of-hospital CPR is that mechanical chest compressions and defibrillators can generate artifacts in the EEG waveform. Most of the information we have about electrical activity in the whole brain comes from in-hospital cases in which the patient's heart stopped while EEG monitoring was conducted, or cases where

EEG monitoring (or a variant thereof) is used during procedures that require anesthesia and/or hypothermia.

The logistics of doing EEG during cardiopulmonary support would not favor this form of monitoring in cryonics. Another complication is that while it has been established that the brain responds to artificial attempts to restore blood flow to the brain, the resulting brain waves would not provide simple actionable information and interpretation of data that lies on the continuum between isoelectric (flat line) and normal values would be hard to interpret. One approach that gets around this challenge is for a computer to process the EEG into a simple numerical score that expresses the degree of brain activity. The need for such a simple measurement has been driven by procedures that require measurement of the depth of anesthesia.

Bispectral index (BIS) is one the dominant commercial technologies that aims to measure the depth of anesthesia by calculating a single number from electroencephalographic measurements. The BIS index ranges from 0 (equivalent to electrocerebral silence) to 100 (equivalent to fully awake and alert). A BIS value between 40 and 60 indicates an appropriate level for general anesthesia. An additional advantage of BIS monitoring are the BIS sensors, which, like the INVOS sensors, are simple and can be non-invasively applied to the forehead of the patient.

Emerging studies on the use of BIS during in-hospital and out-of-hospital CPR are aimed at establishing whether BIS scores during CPR can predict successful resuscitation and neurological recovery. In cryonics, resuscitation is not an endpoint of stabilization procedures. However, continued monitoring of BIS could provide meaningful information about the effectiveness of chest compressions and ventilation. BIS monitoring can also be used to assess the effects of medications administration, in particular the administration of general anesthetics (such as Propofol) and vasoactive medications.

In an ideal cryonics case we would expect to see robust EEG activity during CPS, a change of pattern during Propofol administration, and a gradually flattening EEG as deep hypothermic temperatures are approached. Similarly, in an ideal cryonics case with BIS monitoring we would expect to see an initial high BIS score, followed by a drop to an anesthetic plane after

Propofol administration, and a further, progressive, drop as deep hypothermic temperatures are approached.

One potential drawback of the use of BIS monitoring is that it could draw attention to the not widely known (or appreciated) phenomenon that subsequent recovery of electrical activity in the brain is compatible with pronouncement of legal death. A positive BIS score might raise concern about restoration of awareness of the patient. Cerebral oximetry monitoring may be preferable from this standpoint, but because both clinicians and laypeople recognize that delivering oxygen to a brain of a “dead” person is possible and could support viability of individual neurons, and because anesthetic is used as part of cryonics stabilization procedures, it should be possible to allay concerns about brain activity measurements.

## **Monitoring of Stabilization Medications**

Of all three basic stabilization procedures—induction of hypothermia, cardiopulmonary support, and medication administration—monitoring and evaluating medications administration has received the least attention in cryonics publications (including case reports). This situation is somewhat remarkable because the long list of stabilization medications that characterizes Alcor’s stabilization protocol has no precedent in conventional medicine. In fact, despite many years of research and clinical trials there is no single neuroprotectant that has been approved for stroke or cardiac arrest. Monitoring of stabilization medications of cryonics involves two distinct aspects: administration and efficacy.

The most basic form of medication administration monitoring is to document the timing and administration of all the individual medications. This aim has been achieved in many Alcor cases. The most important objective of documenting the time of administration of the individuals medications and solutions is quality control but documenting the time of administration can also help the cryonics organization in evaluating whether a protocol is realistic and/or effective. For example, there have been a fair amount of cryonics cases where administration of the medications was delayed, incomplete, or abandoned. Some medications require re-constitution or administration

through a syringe filter. In some cases reconstitution or filtration was not successful, which necessitated changes in protocol. Documenting the timing of medications administration is also important because some medication are presumed to be only effective during the early stages of ischemia or are most important when the patient is still at normal body temperature.

The most neglected aspect of medications administration monitoring involves assessing their efficacy. While it is not possible to evaluate the effectiveness (or degree of effectiveness) of all medications, it should be possible to do this for a number of the medications in Alcor's stabilization protocol.

As a general rule, the effectiveness of stabilization medications can be assessed by looking for (expected) physiological responses or outcome measures during a case. For example, a vasoactive medication should be effective in raising blood pressure and an anti-coagulant should prevent clotting of the blood after pronouncement of legal death. In some cases the effects of a medication can be assessed immediately after administration; in other cases the effectiveness can be assessed upon the start of washout or cryoprotective perfusion procedures.

It is not always possible to differentiate the effects of individual medications when they serve the same aim and are given shortly after one another. Many neuroprotectants fall in this category. Assessing the efficacy of such medication will require more rigorous research in a lab. For medications for which individual assessment is possible, the data of one single case do still not give definitive answer regarding efficacy. For example, if no blood clotting is observed after administration of heparin this can be both attributed to the medication, promptly restoring circulation, or even the possibility that blood does not coagulate as a result of stasis.

With these caveats in mind, we are listing some of the individual medications in Alcor's stabilization protocol with notes describing how they can be monitored and what clinical questions we would like to answer.

### *Propofol*

The most important reason for administration of Propofol is to reduce metabolic demand. Since Propofol has adverse effects on blood pressure, it is

important to know whether we achieve this aim. The only kind of monitoring in this document that would be able to help address this question directly is to monitor the bispectral index (BIS) of the patient prior, during, and after administration of the medication.

### *Streptokinase*

Streptokinase is administered to break up existing blood clots. Absence of blood clots is not evidence of the efficacy of streptokinase unless it is reasonable certain that (large) clots were present in the patient prior to administration. The best opportunity for looking for clots is during the initial stages of washout and cryoprotective perfusion. The right atrium is known to have large clots in “dead” patients without anticoagulation.

### *Heparin*

Heparin is administered to prevent the formation of blood clots. Absence of blood clots is not evidence of the efficacy of heparin because restoring normal circulation rapidly can also be assumed to prevent blood clots. The best opportunity for looking for clots is during the initial stages of washout and cryoprotective perfusion. The right atrium is known to have large clots in “dead” patients without anticoagulation.

### *Vasopressin*

Vasopressin is administered to increase blood pressure, and this medication should affect cerebral oxygenation and end tidal CO<sub>2</sub> values. If vasopressin and epinephrine are both administered at the same time, it is not really possible to evaluate the relative contribution or interaction of these medications.

### *SMT (S-methyl-isothiourea)*

SMT is a neuroprotectant that is difficult to evaluate on a case-by-case basis but its positive effects on blood pressure may provide evidence of successful administration.



### *Minocycline*

This is an antibiotic that is used to protect the patient from microbial overgrowth during long transport times. Its efficacy might be assessed by comparing bacterial cultures from patients who received the medication and patients who did not after long transport times.

### *Vital-Oxy*

This is a proprietary emulsion of antioxidants and anti-ischemic compounds. As a neuroprotectant it is difficult to evaluate the efficacy of this medication in a single case, but a comparison of a large number of cases might reveal differences in the degree of edema or ice formation after administration or omission of this agent. A more sophisticated approach would be to look at specific biomarkers of ischemia in the blood.

### *Hetastarch*

The most important property of Hetastarch is as a volume expander and we would expect to see improvement of blood pressure, ETCO<sub>2</sub> values, and cerebral oxygenation, especially in dehydrated patients.

### *THAM*

As the only agent explicitly aimed at maintaining and restoring physiological pH, blood gas analysis should reveal the efficacy of this medication.

### *Decaglycerol*

The most important objective of decaglycerol administration is to decrease cerebral edema (or prevent it) by osmotic force as its predecessor medication, mannitol, did. If cerebral edema is present at the start of stabilization procedures, the effects of decaglycerol should be closely monitored.

### *Maalox*

The most direct way to look at the efficacy of Maalox would be to inspect erosion of the stomach wall, or stomach contents outside of the stomach. The absence of Maalox administration could also express itself in (aggravated) abdominal swelling during whole body perfusions.

## **Monitoring of ischemia**

There are a number of approaches to monitoring the presence and degree of ischemia. The most reliable indicator is to directly measure oxygenation of the brain with a technology such as the INVOS cerebral oximetry system. If oxygenation is sufficient to support normal metabolism of the brain (other things being equal) a cryonics patient could be claimed to suffer no ischemia. It is important to recognize that aggressive cooling may relax the oxygen requirement criteria for the brain. So a patient who's cerebral oxygenation is slightly below normal may not be ischemic if (s) he is cooled rapidly as well. In absence of cerebral oximetry, end tidal CO<sub>2</sub> measurements may be a good indicator of the degree of ischemia. A flat EEG or a low bispectral index score (prior to Propofol administration) is also indicative of ischemia.

One of the most robust indicators of the degree of ischemia in a case is the degree of perfusion impairment during cryoprotective perfusion, edema formation, and ice formation after subzero cooling. The cryonics research company Advanced Neural Biosciences is conducting ongoing studies on the effect of ischemia on the brain and have found that, as a general rule, as the duration of (warm and cold) ischemia increases so does perfusion impairment, (abdominal) edema, and ice formation after subzero cooling. Recent CT scans at Alcor have further corroborated this relationship between ischemia, distribution of the vitrification agent in the brain, and ice formation.

Cryonics organizations would benefit from a simple (compounded) "grade" for each case that integrates all the data collected to assess the overall quality of the case. A number of writers in cryonics have attempted to create such a score to estimate the total amount of ischemia. This topic and other issues concerning comparing cases will be discussed in Appendix 1: Evaluating the Quality of Patient Care and Appendix 2: Writing Case Reports.

## **15: Sample Collection and Analysis**

The use of fluid samples is not confined to assessment of the critically ill patient but can also be used after pronouncement, during stabilization and cryoprotective perfusion, to evaluate the effects and efficacy of cryonics procedures. The rationale for drawing and analysis of blood samples is that, for a patient who receives prompt and effective stabilization, the measured blood gas, chemistry, and electrolyte values should resemble those of a living patient.

There are a number of caveats that need to be made before further introducing the topic:

1. Because cryonics is not available as an elective medical procedure, homeostasis is typically compromised during the dying process prior to the start of stabilization procedures. As a consequence, the aim in cryonics stabilization procedures is not necessarily to maintain the blood sample values that were measured at the start of cryonics procedures, but to improve them as best as practical.
2. Administration of stabilization medications can itself alter electrolyte concentration. For example, the administration of the neuroprotectant magnesium can raise serum magnesium levels.
3. Analysis of samples is not confined to the drawing of blood samples. During remote blood substitution, samples can also be drawn from the circulating asanguineous fluid, and analysis of samples is also an option during cryoprotectant perfusion. Samples can also be drawn from the solutions themselves (prior to use) as a quality control.
4. During cryoprotective perfusion, osmolality and/or the refractive index are measured as an indicator of cryoprotectant equilibration.

This topic will not be discussed here but in the cryoprotective perfusion section of the manual.

Despite persuasive theoretical and practical arguments in favor of collecting fluid samples, there have only been a handful of cases where a concerted effort was made to collect and analyze fluid samples from the very beginning of stabilization procedures. The most important reason why cryonics organizations have routinely omitted fluid sampling and analysis is logistical. When personnel and resources compete for priority, it will often be at the expense of patient monitoring. When cryonics stabilization cases are run with insufficient people, there is little time and/or motivation to draw blood samples from the patient. In addition, drawing blood samples requires medical skills which are not likely to be encountered during local volunteer-driven cases. Unlike temperature measurements, the values obtained during blood and fluid sample analysis cannot be interpreted without basic knowledge of fluid and electrolyte balance. Prior to commercial availability of hand-held devices such as the I-STAT, on-site analysis of blood gases was not possible and samples were collected to be sent to outside labs for analysis.

## **Reports of Blood Gas Analysis in Cryonics Case Reports**

Below is a list and short characterization of all published cryonics cases as of 2011 in which blood and perfusate samples were collected and analyzed after pronouncement of legal death:

- 1, 2, 3.** A-1056, A-1057, and unidentified patient (Alcor, November/December 1983): fluid samples during whole-body to neuro conversion of three patients.
- 4.** A-1068 (Alcor, 1985): blood/perfusate samples.
- 5.** A-1133 (Alcor, 1987): blood/perfusate samples.
- 6.** A-1169 (Alcor, 1989): blood/perfusate samples.
- 7.** A-1242 (Alcor, 1990): blood/perfusate samples.

8. A-1049 (Alcor, 1990): blood/perfusate samples.
9. A-1268 (Alcor, 1990): blood/perfusate samples.
10. A-1260 (Alcor, 1992): blood-perfusate samples.
11. A-1871 (Cryocare, 1995): blood-perfusate samples.
12. A-1110 (Alcor, 1997): perfusate samples
13. SA/CI-95 (Suspended Animation/Cryonics Institute, 2009): blood samples.

The last comprehensive transport and cryopreservation blood-sample analysis was done during the 1995 Cryocare James Gallagher case (A-1871). Aside from one case of cryoprotectant effluent sample analysis in 1997, there was not a single documented case of transport blood gas analysis between 1995 and 2009.

During the mid-2000s, Suspended Animation staff member Aschwin de Wolf expressed renewed interest in the procedure, and both Suspended Animation and Alcor acquired the hand-held I-STAT blood gas analyzer. The first documented case of transport blood gas analysis since 1995 (albeit quite limited in nature) was reported in the 2009 Suspended Animation Curtis Henderson stabilization case report.

## **A Brief History of Blood Gas Analysis**

The history of blood gas analysis starts with the discoveries of oxygen, carbon dioxide, the physiological mechanisms of gas exchange, followed by the identification and biochemical characterization of hemoglobin. The introduction of the pH scale goes back to S. P. L. Sorensen who sought a more elegant replacement for expressing the molar concentration of hydrogen ions. The first blood pH electrode was introduced in 1925. After publication of the first temperature correction tables in 1948, temperature-controlled blood pH equipment became commercially available in the mid-1950s.

Increased use and acceptance of blood gas analysis followed its successful use during the polio epidemic that ravaged Copenhagen, Denmark

in 1952 where the mortality rate dropped from 90% at the beginning of the epidemic to 25% at the end. On-site blood gas analysis moved from the lab to the bedside in order to identify cases of inadequate ventilation and gas exchange. The post-war period also gave rise to a new generation of blood gas analysis technologies, including the introduction of transcutaneous technologies as an alternative to the use of electrodes for the measurement of pH, oxygen, and carbon dioxide. In 1972 the pulse oximeter was introduced, making it possible to non-invasively calculate arterial oxygen saturation using a patient's finger or earlobe.

The use of bedside blood gas analysis suffered a setback when regulatory agencies dictated that only licensed technologists were able to operate blood gas analyzers. As a consequence, blood gas analysis increasingly moved back to clinical pathology laboratories. In recent decades the introduction of portable hand-held blood gas analyzers such as the I-STAT are reversing this trend as these devices do not require the same certification as that is needed to operate conventional blood gas analyzers. The use of pulse oximetry has further reduced the need for conventional (invasive) blood gas analysis.

## **Blood Gas Analysis in Cryonics**

There are three distinct methods available for blood and perfusate gas analysis in cryonics:

1. Blood sample collection by the cryonics organization and (delayed) off-site analysis by a third party (usually a laboratory).
2. Blood sample collection by the cryonics organization and delayed off-site analysis by the cryonics organization.
3. Blood sample collection by the cryonics organization and on-site analysis by the cryonics organization.

With the exception of the 2009 Suspended Animation case listed above, all blood analysis in cryonics has been done after completion of procedures by either a third party or the cryonics organization. The recent commercial availability of hand-held blood gas analyzers such as the I-STAT has made

on-site blood gas analysis and real-time intervention a realistic and cost-effective possibility.

In some cryonics cases, specific parameters have been measured on-site while arterial blood samples were chilled for lab analysis at a later point. For example, Alcor case A-1068 documents on-site pH measurements using a portable pH meter, and in the past blood glucose kits were included in Alcor's standby kits. Other monitoring devices that can provide (real-time) information about gas exchange and ventilation efficacy, such as pulse oximeters and end tidal CO<sub>2</sub> detectors, are covered in the general chapter about monitoring.

During stabilization procedures such as cardiopulmonary support (CPS), blood gas analysis is only possible by drawing a blood sample from the patient and analyzing it on-site or submitting it to a laboratory at a later date. In the case of blood substitution and cryoprotective perfusion, blood or perfusate analysis can be conducted by using inline blood gas analyzers such as the CDI™ Blood Parameter Monitoring System. This system uses optical fluorescence and reflectance technologies to continuously monitor blood gas parameters (up to 11 in the latest version). The target market for such devices is extracorporeal perfusion, but these technologies can also be used in cryonics procedures such as blood substitution and cryoprotective perfusion. The system uses a shunt line that allows the circulating blood (or perfusate) to come into direct contact with the sensor. One of the caveats of such systems is that it can only measure values within a specific range. This range usually is adequate for conventional perfusion procedures, but in some circumstances (such as pH and temperature) the values that are observed in cryonics may fall outside this range. As of writing, there is no documented example of using such inline devices for the measurement of physiological parameters in asanguineous solutions at ultra-profound or subzero temperatures.

## **Blood Sample Collection**

If a decision is made to draw blood and perfusate samples, the first step is to ensure the presence of the proper supplies and qualified personnel to draw samples. Whereas some blood gases can be measured non-invasively, a

complete panel of blood gases, chemistries, and electrolytes requires drawing a blood sample from the patient. In principle, a blood sample can be drawn by inserting a needle into a vessel and drawing a suitable amount of blood. In practice, team members may want to place an IV to allow for repeated sampling from the same location. It is strongly recommended to place a separate IV line for blood sample collection. If blood samples are drawn from the same IV that is used for medications administration the likelihood of delays, errors, and faulty samples is increased.

Blood samples do not necessarily have to be drawn from a vein. It is possible to obtain blood samples from an artery, such as the radial artery at the wrist. Since this procedure is not recommended for non-professionals, it will not be discussed in this document. A special case of collecting arterial blood gases is to draw a sample from the femoral artery. There is not a realistic option during the initial stages of stabilization, but it is a possibility when surgery is performed to cannulate the femoral artery for blood washout.

There are various methods to collect venous blood samples. Unless the blood is analyzed on-site with the I-STAT, all methods require venipuncture and a collection tube for the blood. One advantage of using the I-STAT for blood sample analysis is that only a very small sample is required – just a few drops.

The most routine method for phlebotomists is to perform venipuncture with a blood collection tube. The most popular system is BD's vacutainer. The vacutainer system consists of a plastic holder, double sided-needle, and a collection tube. One side of the needle is used to puncture the skin and the other side enters the plastic holder. After the needle is correctly inserted into the vein the rubber top of the blood collection tube is pushed into the needle in the plastic holder. The vacuum in the tube draws the blood into the blood collection tube. The vacutainer system allows for the drawing of multiple samples by changing the blood collection tubes. A major advantage of the vacutainer system is that it ensures the right amount of blood is drawn at a safe speed. There are also a number of disadvantages. Unlike conventional venipuncture, in the vacutainer procedure there is no blood flashback to confirm correct placement of the needle in the vein.



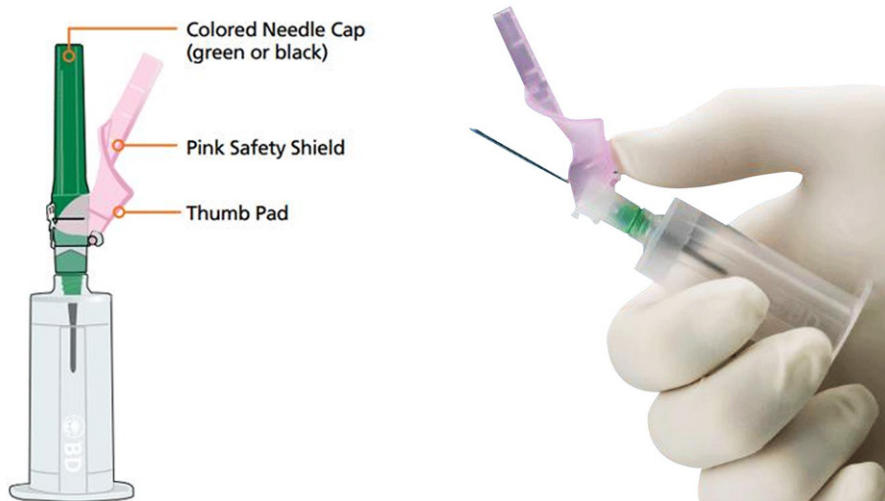

Figure 15-1. BD Vacutainer Eclipse Blood Collection Needle with Luer Adapter.

In principle, it is possible to secure the vacutainer needle to allow for intermittent blood samples, but during transport of a cryopatient team members may prefer to place an intravenous line. Blood samples can be drawn with a syringe, using a stopcock or directly from the line, and transferred to a blood collection tube. The disadvantage of this method is that the amount of blood and the speed at which the blood are drawn are not determined by the system. Another disadvantage, compared to the vacutainer system, is that such an “open system” can lead to spilling of blood during collection. Such events can be prevented by using a so-called “butterfly needle” which has flexible tubing attached to the small needle to connect a vacuum blood collection tube or syringe.

The small volume necessary to do on-site blood analysis with the I-STAT permits capillary blood sampling. Capillary blood collection involves the puncture of a well vascularized portion of the skin, such as the fingertips, to collect a few drops of blood from the patient. Like other venipuncture systems, capillary blood collection systems are available with safety features and anti-coagulant coating. One limitation of capillary blood sampling is that the obtained blood contains undetermined proportions of blood from

arterioles, venules, capillaries, and interstitial and intracellular fluids, which makes it harder to determine the proper reference values.

Blood collection tubes often come in different colors to reflect the various additives (or lack thereof) to the tubes. For example, for some tests whole non-coagulated blood is required whereas for other tests a gel is added to separate the serum after centrifugation. The meaning of the different colors is standardized between manufacturers. To prevent additives from one sample contaminating subsequent samples, a recommended order of draw has been established.

















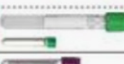

Order of Draw			
Tube Closure Color	Collection Tube	Mix by Inverting	Min. Clot Time
	 Blood Cultures – SPS	8 to 10 times	N/A
	 Citrate Tube (Light Blue)	3 to 4 times	N/A
	 Serum Separator Tubes (Gold and Tiger)	5 times	30 minutes
	 Serum Tube (Red)	5 times (plastic) None (glass)	60 minutes
	 Rapid Serum Tube (Orange)	5 to 6 times	5 minutes
	 Plasma Separator Tube	8 to 10 times	N/A
	 Heparin Tube (Green)	8 to 10 times	N/A
	 EDTA Tube (Lavender)	8 to 10 times	N/A
	 PPT Separator Tube (Pearl)	8 to 10 times	N/A
	 Fluoride Tube (Gray)	8 to 10 times	N/A

Figure 15-2. Example of Vacutainer® colors and order of draw

## Perfusate Sample Collection

Collection of perfusate samples is relatively straight forward. Unlike the collection of blood samples, the drawing of perfusate samples does not require

an additional invasive step because the samples can be drawn from the arterial or venous line. This also provides an opportunity to draw an undiluted initial blood sample at the start of washout in the field or in the OR. As the blood is gradually washed out, these samples will progressively become more diluted. At this point it should be noted that drawing a sample during the later stages of blood washout or cryoprotective perfusion does not guarantee that a pure perfusate sample will be obtained because blood components can still be released into the effluent as a result of delayed opening of vessels.

One exception to the non-invasive nature of perfusate sample collection is when a sample is obtained from the burr holes of the patient to monitor cryoprotectant equilibration (see the chapter on cryoprotective perfusion).

Perfusate samples can be obtained directly from the line by using a “screw-type” syringe with a Luerlock end. The syringe is either used directly in the sample port of the line, or from a bypass line with a sample port to prevent errors such as inadvertently introducing air into the circuit. If a (relatively) pure sample of the perfusate is required as a control sample it must be taken from the arterial line at the start of perfusion or during priming. If a perfusate sample is drawn to obtain information about the patient, the sample needs to be drawn from the venous line. A safer alternative to using arterial samples to check the perfusate is to simply draw a sample from the perfusate container or during priming of the circuit.

After drawing the perfusate sample it is stored in the appropriate container or tube for later analysis or analyzed on-site to obtain direct feedback.

## **Blood Sample Analysis**

In the past, Alcor has used conventional blood testing equipment to test blood samples, but since such relatively bulky devices confer little benefit over a handheld blood analyzer they will not be discussed here. If the samples are sent out to a third-party lab for analysis, the samples should be refrigerated after collection, and preferably be shipped at that temperature as well. If the blood samples will not be analyzed before seven<sup>7</sup> days, the samples can be frozen to dry ice temperature.

The I-STAT is a portable blood gas analyzer made by the Abbot Corporation. For cryonics casework it has a number of distinct advantages:

1. It is light (18 oz), portable, and can be included in standby kits or travel bags.
2. It permits on-site analysis of blood and perfusate samples.
3. Only a few drops of blood are required for analysis.
4. It does not require difficult operating instructions for calibration or use.
5. A wide variety of cartridges allows for different kinds of tests.
6. The data can be uploaded to a computer or printed on-site



*Figure 3. I-STAT with cartridges*

As of writing, cartridges are available for the following blood measurements:

**Chemistries/Electrolytes**

Sodium (Na)  
Potassium (K)  
Chloride (Cl)  
TCO<sub>2</sub>  
Anion Gapa  
Ionized Calcium (iCa)  
Glucose (Glu)  
Urea Nitrogen (BUN)  
Creatinine (Crea)  
Lactate

**Hematology**

Hematocrit (Hct)  
Hemoglobin (Hgb)a

**Blood Gases**

pH  
PCO<sub>2</sub>  
PO<sub>2</sub>  
TCO<sub>2</sub>a  
HCO<sub>3</sub>a  
Base Excess (BE)a  
sO<sub>2</sub>a

**Coagulation**

ACT Kaolin  
ACT Celite®

**Cardiac Markers**

PT/INR  
cTnl  
CK-MB  
BNP

To date, there is only documented cryonics case in which the I-STAT was used in a cryonics case, and there remain a lot of unknowns. One of the current unknowns is how well the I-STAT will perform with asanguineous samples. For example, MHP-2 is a high potassium intracellular perfusate but the reportable range for the I-STAT is 2.0-9.0 mmol/L (for a complete overview of the I-STAT functionalities, cartridges and reportable ranges, see the manufacturer's website).

The I-STAT does not require much in terms of maintenance but it is important to run the most recent software and to ensure that the cartridges are stored properly and not used beyond their expiration dates.

## **Interpretation of Blood Samples**

In an ideal cryonics case (a cryopreservation conducted at a hospital), the patient would not suffer ischemia and we would expect and aim for blood gas and chemistry values to be within the normal range until the blood of the patient is washed out with a suitable solution.

*Normal Blood Gas and Chemistry Values*

		Arterial	Venous
pH	A measure of acidity or alkalinity	7.35 – 7.45	7.31 – 7.41
pO <sub>2</sub>	Partial pressure of oxygen	75 – 100 mmHg	30 – 40 mmHg
pCO <sub>2</sub>	Partial pressure of carbon dioxide	35 – 45 mmHg	41 – 51 mmHg
TCO <sub>2</sub>	Total concentration of carbon dioxide	24 – 30	25 – 33
HCO <sub>3</sub> <sup>-</sup>	Bicarbonate	22 – 26 mEq/L	22 – 29 mEq/L
O <sub>2</sub> Sat	Saturation of oxygen	95 – 100% (sea level; room air)	60 – 85%
BE	Base Excess	-2 to +2 mmol/L	0 to 4mmol/L
Lactate		4.5 - 14.4 mg/dL	4.5 – 19.8 mg/dL
NA	Sodium	135 - 145 mEq/L	
K	Potassium	3.5 – 5.0 mEq/L	
Cl	Chloride	95 – 105 mEq/L	
Ca	Calcium (ionized)	2.2 – 2.5 mEq/L	
Mg	Magnesium	1.6 – 2.6 mEq/L	
PO <sub>4</sub>	Phosphorus	2.5 – 4.5 mg/dL	
BUN	Blood Urea Nitrogen	5 – 25 mg/dL	
Creatinine		0.5 – 1.5 mg/dL	
Hgb	Hemoglobin	Male: 13 – 18 g/dL; Female: 12 – 16 g/dL	
Hct	Hematocrit	Male: 42 – 52 g/dL; Female: 37 – 47 g/dL	
Anion Gap		10 – 12 mEq/L	
Osmolality		280 – 300 mOsm/kg	
Albumin		3.5 – 5 g/dL	
Total Protein		6.0 – 8.0 g/dL	

In more realistic scenarios we expect the patient to experience circulatory arrest, (cerebral) ischemia, and hypo-perfusion during CPS. In many cases the blood and chemistry values will be outside of the normal range prior to circulatory arrest because conventional medical treatment of the patient has been halted. This means that blood and chemistry values obtained immediately at the start of stabilization are not necessarily a healthy range, but a baseline to which the effects of stabilization procedures can be compared.

As discussed in the introduction, a value outside of the normal range does not necessarily mean that the patient would be better off if his values would fall inside the normal range. Some of the body's responses to circulatory arrest or hypo-perfusion may produce abnormal values but could actually be cerebroprotective, such as a drop of pH during cerebral ischemia. Additionally, administration of medications can alter blood chemistries without such an event being indicative of a deteriorating (or improving) situation. For example, the administration non-electrolyte fluids can depress electrolyte levels in the blood.

Our understanding of what values would be "ideal" during cryonics stabilization cases is almost non-existent and, keeping these caveats in mind, our best interpretation of the results to date is to simply determine to what degree our measured values compare to normal values.

## **Blood and Perfusate Analysis in Cryonics Cases**

In this section we attempt a general overview of the documented cryonics cases in which blood and/or perfusate analysis was conducted. One complicating factor in evaluating these cases is that cases where blood samples were analyzed also tend to be generally "good" cases. After all, sample collection and analysis is not a core stabilization procedure and is usually possible only in cases where timely intervention with sufficient personnel and equipment is available. As a consequence, we have a rather poor understanding of what blood and perfusate samples look like in non-ideal and poor cases. We can compare results with normal values but it remains difficult to tell how these values compare to what would have been the case without standby and stabilization interventions.



Below, we present notes of *selected* cryonics cases where blood and perfusate analysis was conducted.

*Alcor A-1056, A-1057, and unidentified patient*

For all three patients fluid samples were obtained from the body of the patients after neuro conversion. The report specifies cryoprotectant osmolalities for all three patients in fluids obtained from different parts of the body. The author suggests that the low and variable distribution of cryoprotectant can be attributed to low volumes of the cryoprotectant and ischemia-induced perfusion impairment. In one patient light microscopy shows evidence of red blood cell agglutination.

*Alcor A-1068*

The case report for A-1068 contains an extensive discussion of blood, washout perfusate, and cryoprotectant perfusate samples. Reported cryonics transport electrolytes show values below normal for calcium and sodium, and elevated potassium, indicating hemodilution and/or inadequacy of cardiopulmonary support.

pH measurements during extracorporeal perfusion are reflected in the graph in Figure 15-4:

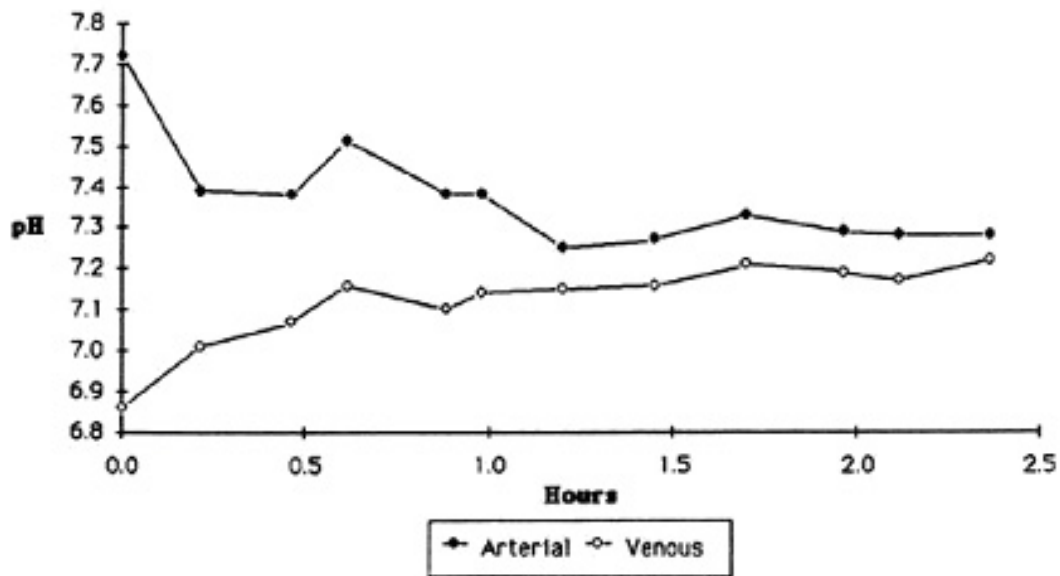

Figure 15-4. pH measurements during extracorporeal perfusion of Alcor case A-1068.

The venous drop in pH is attributed to the inadequate buffering capacity of the perfusate and the possibility of increasing HEPES is discussed. Interestingly, one of the changes from MHP to MHP-2 was to increase the concentration of HEPES from 7.2 mM to 15 mM.

There has been some debate in cryonics about the desirability of calcium in washout and cryoprotectant carrier solutions. In this case, calcium levels from both the burr hole and the recirculating cryoprotective perfusate were low but well in excess of the 50  $\mu\text{M}/\text{L}$  threshold below which membrane damage is known to occur.

### *Alcor A-1133*

This case report has an extensive appendix with graphs of blood gases, electrolytes, and enzymes data during cryoprotective perfusion. The author observes that the increase of some enzymes (SPK, LDH and SGOT) indicate progressive release from body tissues despite hemodilution.

*Alcor A-1169*

After 3 hours and 8 minutes of cardiopulmonary support and cooling to 23.5 degrees C, the first venous pH at the start of washout was 7.16, which may be attributed to administration of THAM during transport. After termination of blood washout, pH is 7.80, which the writer of the case report attributes to the addition of “a modest amount” of potassium phosphate to augment the HEPES buffer in the perfusate.

*Alcor A-1242*

This report documents a venous pH of 6.41 at the start of washout after a prolonged period of circulatory arrest without comprehensive and ongoing stabilization procedures.

*Alcor A-1049*

This is one of the most comprehensive cryonics case reports ever written and contains extensive data and analysis of blood and perfusate samples. In this case, a concerted effort was made to keep the patient viable by contemporary medical criteria and the serum chemistries indicate a relatively successful effort. Up until the removal of blood, the blood looked bright red and free of agglutination and clots, indicating successful oxygenation, anti-coagulation and mitigation of red cell aggregation. pH remained slightly basic until the end of cryoprotective perfusion, indicating robust protection against ischemia and good buffering activity of the washout solution and cryoprotectant carrier solution.

This case also stands out for conducting a renal viability evaluation, which was possible because the patient was a neuro patient. The patient’s kidney was subjected to renal slice potassium / sodium ratios in a cryobiology lab and the average ratio of 3.5 corresponds to the expected value for such slices after a storage time of approximately 2.5 days.

This case report also emphasizes the importance of perfusing a dehydrated patient with elevated serum osmolality with a hyperosmolar perfusate to avoid edema and cell lysis. This is one of the reasons why MHP-2 is formulated as a hyperosmolar perfusate. The report also stresses the value of comparing transport and washout samples to a baseline blood sample to

estimate the degree of hemodilution, the recruitment of interstitial and intracellular fluid to the vascular space, and the uniformity of blood washout.

### *CryoCare A-1871*

This case is considered one of the best stabilization cases performed in cryonics, especially in terms of rapid cooling. The pH measurements during stabilization are consistently below physiological values but the author mentions that the team deliberately aimed for a lower pH (in the range of 7.0 to 7.2) because of its protective properties during ischemia. During cryoprotective perfusion pH approximated physiological values.

Venous oxygen saturation during stabilization was above physiological values, indicating vigorous cardiopulmonary support, ventilation and rapid cooling (reducing oxygen utilization). Other indicators such as potassium and sodium were slightly outside of the normal range but not nearly near the values that would be expected in the presence of severe ischemia.

Abnormally high values were observed for glucose, which the author attributes to failure of glucose regulation. Lactate levels were also elevated and continued to increase up until cryoprotective perfusion.

### *Alcor A-1110*

This case report presents a comprehensive series of cryoprotective perfusate sample measurements and was conducted during a period where routine blood and perfusate sampling and analysis had been all but abandoned. There is no detailed analysis of these measurements in the report. The low osmolality measurements may reflect an error in carrier solution formulation.

### *Suspended Animation / Cryonics Institute-95*

This is the only recent case in which a transport blood sample was collected. This case is also unique for the use of the I-STAT. There is no discussion of this single blood sample and lack of a context and specific timestamp does not permit a meaningful analysis in this report.

As has become obvious from this brief discussion of the results of blood and perfusate analysis in cryonics cases, the practice has been gradually

abandoned. In addition, there is no or little analysis in more recent case reports.

## **Specific Biomarkers of Cerebral Ischemia**

In the forensic sciences and biomedical research it has been found that (cerebral) ischemia reduces pH, elevate lactate, reduce calcium and sodium serum levels, and elevate serum potassium levels. A more focused approach has been to look for specific biomarkers of cerebral ischemia.

To distinguish cerebral ischemia from other common insults there has been a concerted search for bloodborne biochemical markers that, individually, or in combination, can lead to a credible diagnosis of cerebral ischemia or stroke. Among those biomarkers are N-acetyl aspartate, glutamate, taurine, matrix metalloproteinase 9, brain natriuretic factor (BNP), d-dimer, and protein S100 $\beta$ .

To date there have not been any attempts to identify specific biomarkers, or combinations of them, to evaluate the efficacy of stabilization and cryopreservation procedures. The phenomenon of cryoprotectant toxicity may also lend itself to the identification of bloodborne compounds that are associated with cell lysis or other mechanisms of cryoprotectant toxicity.

## **16. Remote Blood Washout**

This section consists of two parts. In Part 1, the rationale and practice of remote blood substitution is reviewed. In Part 2, the history and conduct of extracorporeal perfusion is reviewed.

### **Part 1**

In an “ideal” cryonics case the patient is pronounced legally dead as close to the cryonics facility as possible to minimize the period between cardiac arrest and long term care after vitrification. In contemporary cryonics, local stabilization is only possible in a minority of cases, and in remote cases there can be situations in which no stabilization is possible (i.e., sudden death, autopsy, no standby).

When remote standby and stabilization procedures are possible, the current protocol is to wash out the blood of the patient and substitute it with an organ preservation solution prior to air shipment or ground transport. Although the desirability of remote blood substitution goes back to the first cryonics transport manual in 1972, the routine practice of blood substitution in cryonics goes back to the early 1980s, and reflects findings in hypothermic resuscitation research and clinical hypothermic organ preservation. Since then a substantial number of cryonics patients have undergone remote blood washout prior to shipment to a cryonics facility.

Over the last ten years there has been increasing concern that blood washout is counterproductive, or should be restricted to only some cases, or should be undertaken only if better preservative solutions are developed and validated in a model clinically relevant to cryonics patients. Some cryonics observers have expressed concern about performing blood substitution in patients after long periods of (cold) ischemia and/or long periods of

cardiopulmonary support because of the prospect of serious reperfusion injury and related concerns such as edema or aggravating injury to the patient's circulatory system.

The current remote blood washout procedures are supported by the canine asanguineous ultraprofound hypothermia research that Michael Darwin, Jerry Leaf et al did in the mid-1980s[1]. In these experiments dogs were resuscitated from up to five hours of low-flow asanguineous ultraprofound hypothermic circulation (temperature <10 degrees Celsius). This model raises a number of questions. The most obvious question is whether these results warrant extrapolation to longer periods of low-flow perfusion and circulatory arrest. In typical cryonics patients, the period between blood substitution and long term care exceeds the period of asanguineous hypothermia in the experiments mentioned above. And with the exception of a small number of older cryonics cases, current patients are *not perfused during transport* to the cryonics facility. Barring actual experiments, it cannot be assumed that blood substitution of cryonics patients, followed by periods of 24 hours or more of circulatory arrest during transport, is superior to no blood substitution or remote extracorporeal bypass without blood substitution. This concern is further justified by the fact that the original canine experiments were done on *non-ischemic healthy* animals, whereas cryonics patients are almost invariably aged, fragile and ischemic, and even under the best conditions experience severe agonal injury.

Another concern that has been raised involves the composition of the perfusate. There is now documented evidence that recent perfusate preparation and composition differs from the clinical considerations that informed perfusate composition during the original canine experiments and subsequent application of these solutions to cryonics patients and earlier cryonics cases. A related issue is that human cryopreservation might benefit from validation and introduction of a new generation of cold organ preservation solutions and/or new protocols. The MHP-based cold organ preservation solutions are now more than 30 years old, and research in and outside of cryonics has developed new cold organ preservation solutions that may be superior to MHP-based perfusates. For example, one design consideration for cold organ preservation

solutions for *cryonics patients* would be to include neuroprotective agents in the perfusate.

A final concern that will be addressed is whether the current state of expertise at Alcor (or associated organizations) warrants routine remote blood substitution. Remote blood substitution is a non-trivial procedure, requiring surgical skills and operation of a portable heart-lung machine, and can cause great harm to a cryonics patient if not executed correctly. For this reason, since 2011 Alcor has had a policy using the contractor Suspended Animation, Inc. (SA) to perform blood substitution of Alcor patients in the continental United States outside of Arizona. SA in turn contracts with cardiothoracic surgeons and clinical perfusionists, who are medical experts in accessing large blood vessels and diluting or replacing blood.

## **Why Blood Substitution?**

There are three important reasons for remote blood substitution:

1. Elimination and prevention of blood clots.
2. Rapid induction of ultraprofound hypothermia.
3. Maintaining viability of the brain during transport to the cryonics facility

Two related objectives are the elimination of inflammatory products in ischemic patients, and maintaining circulation after cardiopulmonary support.

### *Circulatory Arrest and Blood Clotting*

Perhaps the most fundamental reason to replace the blood with an organ preservation solution is to eliminate blood clots and to prevent blood clotting (or related blood abnormalities). The reason for this is obvious; if a patient suffers from massive micro and macro- blood clotting, subsequent attempts to perfuse the patient with a vitrification agent will be sub-optimal or fail completely.

Despite this obvious objective, it is not clear why circulatory arrest should necessarily induce blood clots. Scientific discussion of the relationship



between circulatory arrest and blood clotting is rare. This lack of scientific literature on this issue is also problematic in light of the fact that clotting can be unpredictable; clots sometimes are observed in cryonics patients, but other times perfusion is apparently successful after long ischemic times even without heparin administration. These anecdotal observations should be qualified by stressing that the lack of visible clotting and the ability to cryoprotectant such patients, does not rule out the absence of harmful micro-thrombi which can leave parts of the brain non-perfused. Areas of the brain that are shut off from circulation risk straight freezing, defeating the purpose of vitrification and increasing the demands on future resuscitation technologies.

Most models that have investigated coagulopathy in shock, cardiac arrest, and stroke *restore circulation* after various periods of ischemia (or low perfusion) and measure coagulation times and various plasma concentrations of blood components such as fibrogen and platelets. Hossmann et al. induced 1 hour of normothermic cerebral ischemia in cats and found reduced electrophysiological recovery from prolonged normothermic recovery in animals with lower post-ischemic fibrinogen concentrations[2]. Similarly, Cerchiari et al. observed hypocoagulability after 7.5 to 12.5 minutes of cardiac arrest in dogs, indicating hypercoagulability and disseminated intravascular coagulation (DIC) early after cardiac arrest. Böttinger et al. investigated hemostatic changes in humans during cardiopulmonary resuscitation (CPR) and found marked activation of blood coagulation and fibrin after prolonged cardiac arrest and CPR without concomitant activation of fibrinolysis[3]. The authors propose that these events contribute to the post-resuscitation “no reflow” phenomenon, in which some areas of the brain do not perfuse.

In contrast, Fisher et al. designed an elegant experiment in which rabbits were perfused with carbon black after various durations (4.5, 15, and 30 min) of cerebral ischemia and different reperfusion protocols[4]. They found no difference between untreated animals and animals pre-treated with heparin after 15 minutes of ischemia. In both groups cerebral perfusion was impaired. In animals that were re-perfused with increased pressure or hemodiluted with saline, less perfusion impairment was observed. This study indicates that formation of thrombi does not occur within the durations of ischemia that

were studied. But perhaps the conclusions from Böttinger et al. and Fisher et al. can be reconciled if we allow for the possibility that cerebral ischemia *does* induce formation of *micro-thrombi* but these are not of such a magnitude that cerebral circulation is greatly impaired. Tisherman et al. have observed large vessel blood clots in rats and dogs after 20 minutes of normothermic cardiac arrest induced by drowning[5]. The success of hypertension and hemodilution in mitigating the no-reflow phenomenon does indicate that rheological and vascular problems are involved in impaired perfusion after cerebral ischemia. For example, Safar et al. obtained better cerebral outcome after 12 minutes of cardiac arrest in dogs using hypertensive reperfusion, heparin, and dextran administration[6]. In recent research conducted at Advanced Neural Biosciences in the rat model administration of heparin (and streptokinase) was not sufficient to prevent perfusion impairment and prolonged periods of warm and cold ischemia.

Although it is often taken for granted that blood clots form after cardiac arrest, the mechanisms for this are rarely discussed. Since blood stasis by itself does not activate the *intrinsic* or *extrinsic* clotting cascade, some elucidation of these mechanisms in the context of cryonics would be helpful. One proposed explanation is that red blood cells modify their cytoskeleton when they stop moving. The cytoskeleton becomes more rigid when the laminar flow through the vessels is lost, exposing phospholipids at the membrane surface, which trigger the coagulation cascade[7]. This raises the question of whether blood clots during stasis or whether thrombi are formed during reperfusion because of failure of the fibrinolytic system. In contrast, in forensic medicine it seems to be common knowledge that blood becomes “permanently incoagulable” within 30-60 minutes of death[8]. In a recent book length treatment of deep venous thrombosis (DVT), P. Colm Malone and Paul S. Agutter conclude that blood cannot coagulate in a cadaver and that all thrombi (which the authors carefully distinguish from in vitro clots) are agonal in nature. The “mode of death” framework they present allows the authors to explain why thrombi are found in some cadavers but not in others. In the case of *sudden* circulatory arrest we would not expect much benefit from “post-mortem” anti-thrombotic therapy, whereas in the case of gradual and selective circulatory failure (shock) we would expect increased thrombi formation[9].

As the work of Fisher et al. indicates, leaving the blood in the patient may present other challenges than blood clotting such as platelet activation, adhesion and rolling of white blood cells, cold-induced red cell aggregation, and hyperviscosity. Studying the mechanisms of all these phenomena in the context of cryonics will be a formidable task. The most realistic direction so far has been to design experiments to investigate the difference between various remote stabilization protocols with quality of (cryoprotectant) perfusion as an endpoint. The most fundamental question in this context is to investigate if there is a difference between the quality of perfusion in models with and without blood washout, looking at various lengths of cold ischemic storage times, and comparing different organ preservation solutions.

### *Rapid Induction of Ultraprofound Hypothermia*

One clear advantage of remote blood substitution is that obtaining access to the circulatory system enables the cryonics stabilization team to induce internal cooling, which produces superior cooling rates compared to any other method of (external) cooling. Strictly speaking, extracorporeal cooling does not imply blood substitution. If it would be established that the other advantages of remote blood substitution are absent, or even counter-productive, the portable heart-lung machine could just still be used to induce ultraprofound hypothermia (core temperature between 0 and 5 degrees Celsius) without washing out the blood and substituting it for an organ preservation solution. In the future, cold cyclic lung lavage could take over this remaining use of extracorporeal perfusion, provided it can achieve comparable cooling rates and that prolonged CPS at low temperatures is not detrimental. Since the advantages of rapid induction of hypothermia in cryonics are not controversial, this (indirect) advantage of remote blood substitution will be assumed as a given in this chapter.

### *Maintaining Viability*

Another important objective of blood substitution is to maintain viability, and that of the brain in particular, during cold transport of the patient. The assumption is that an artificial “whole body” preservation solution will limit ischemic injury to a greater extent than leaving the blood in the patient.

Ischemia-induced edema can occur during stabilization, total body washout, and transport, and becomes acute upon initiation of CPA perfusion. This edema can be so severe both systemically and in the brain that it precludes completion of CPA perfusion. Another serious complication is fulminating pulmonary edema, stomach and gut leakage of perfusate that either exhausts the available stock of perfusate or, in some cases, is so severe it precludes the maintenance of adequate arterial perfusion pressure. This latter complication presumably reflects severe injury to the integrity of the capillary endothelium and to the underlying basement membrane.

The question in cryonics is whether it is reasonable to extrapolate evidence of superior ultrastructure and viability achieved with asanguineous ultraprofound hypothermic arrest in healthy animals to cryonics patients who are (often) old, ischemic and exposed to much longer times of hypothermic circulatory arrest. Before reviewing this issue it will be good to briefly review the state of the art in mainstream hypothermic organ preservation and asanguineous hypothermic resuscitation.

## **Hypothermic Organ Preservation**

The history of hypothermic organ preservation is closely linked to the history of organ transplantation. To maintain viability between the time of organ harvesting and transplantation a number of techniques can be deployed ranging from warm perfusion to asanguineous cold storage.

The most basic perfusate is no perfusate at all, but rather hypothermic perfusion of isolated organs with whole blood. Although organs have been preserved in this manner, there are some major disadvantages to this method. Cold induces red cell sludging and during hypothermia hemoglobin holds oxygen so tightly that it gives up little oxygen. Other alternatives include plasma, cryoprecipitated plasma and perfusates of serum or fractions of serum. Because these alternatives still suffer from issues such as the presence of unstable lipoproteins, clotting, precipitation, cytotoxic antibodies, and contamination issues, improved perfusates were designed that were completely synthetic and a-cellular in nature. Perfusates can either contain a colloid (like albumin) or no colloid. The most popular cold organ preservation

solutions today contain artificial colloids and a number of components to provide metabolic support, stabilize pH, prevent edema, protect against free radical injury, and protect against cold cell swelling.

The organ preservation solution that Alcor uses today, MHP-2, is an “intracellular” type cold organ preservation solution. MHP-type solutions are similar to Viaspan, also known as University of Wisconsin solution (UW solution), still the “gold standard” for organ preservation solutions. Intracellular cold organ preservation solutions mimic the intracellular ionic environment. Although lower temperatures will reduce the rate of biochemical reactions, the rates of *biophysical* events (such as diffusion) do not decrease at the same rate. Cold impairs ATP-driven ion pumps in cell membranes, but passive transport continues as ions move down their electrochemical gradients causing membrane depolarization, intracellular calcium overload, cell swelling, and ultimately, cell death. To prevent such events, intracellular cold organ preservation solutions are high in potassium (hyperkalemic) and low in sodium. This ensures that the intracellular environment remains in its natural high potassium state as diffusion equalizes intracellular and extracellular ion concentrations during failure of ion pumps in cell membranes. Cold preservation solutions also derive most of their tonicity from relatively large impermeable solutes such as mannitol. This is necessary to prevent “colloid osmotic cell swelling.” Free diffusion of small ions into cells during failure of cell membrane ion pumps leaves large impermeable intracellular anions (negatively charged proteins or “colloids”) as the most effective osmotic agents when cells are cold. If liquid surrounding cells contains only small permeable ions such as sodium, potassium and chloride when ion pumps fail, then the impermeable anions inside cells osmotically draw water into cells and cause cells to swell. The inclusion of large impermeable osmotic agents such as mannitol or lactobionate in organ preservation solutions counterbalances the osmotic effect of large anions inside cells, and prevents cell swelling that would otherwise occur while membrane ion pumps are impaired. Other components that are important to MHP-type and UW solutions are hydroxyethyl starch, which by being impermeable across capillary walls provides colloid osmotic support to keep blood vessels open and prevent edema, and glutathione to scavenge free radicals. As will be discussed later,

the major difference between MHP-2 and Viaspan is that the former includes the impermeable component mannitol and the latter the more expensive sugars lactobionate and raffinose. MHP based cold organ preservation solutions were designed to reflect the state of the art in cold organ preservation at the time (1980s) and to allow for hypothermic asanguineous resuscitation.

### *Hypothermic Perfusion Preservation*

Although hypothermic perfusion preservation (HPP) was an important modality of organ preservation, this technology has been increasingly replaced by static hypothermic storage because of logistics, cost, and improvement in cold storage solutions such as UW solution. One major limitation of hypothermic static storage is that there are finite limits to the length of time organs can be maintained at low temperatures without running into energy shortages and associated cell death. HPP has an advantage over static storage because it can deliver cell nutrients to the tissues and remove CO<sub>2</sub> and other metabolic waste products. Hypothermic perfusion also allows for reversal of the early stages of warm ischemia such as edema and microcirculatory failure. The physiological benefits of HPP include sustenance of mitochondrial electron transport, reduction of apoptosis, improved circulation after warm ischemia, and the ability to actively regulate pH and administer cytoprotective and immuno-modulating drugs[10].

Most potential negative features of HPP mirror the positive features of the technology. Although HPP can improve preservation of ischemic organs, it can also worsen them by exerting high pressures, high viscosity, and excessive shear stress. This risk is particularly important in cryonics because most cryonics patients experience long agonal periods, shock, cardiac arrest, and hypoperfusion during cardiopulmonary support. Another potential disadvantage of HPP is the risk for increased interstitial and cellular edema when organs are perfused with solutions without adequate oncotic support. This presents another major risk for cryonics patients because such events can frustrate later attempts to cryoprotectant the brain. The practice of continuous (vs. intermittent) perfusion in cryonics, and the choice of the right oncotic agents will be discussed in more detail below.

### *Hypothermic Preservation of the Isolated Brain*

Research into hypothermic preservation of the *isolated brain* is very rare. The most important reason for this is that unlike other organs, the brain is the seat of the identity of the person and cannot be swapped for another brain without changing persons. Although it may become technically feasible to replace the body of a critically ill patient with another body, such a procedure raises technical and bioethical challenges. One researcher who explored “brain transplants” and brain preservation is Dr. Robert J. White (1925-2010). Obviously, studies of hypothermic preservation of the brain are of great importance to cryonics and the practice of remote blood substitution in particular.

In 1963, White et al. *perfused* an isolated monkey brain in vitro at hypothermic temperatures and observed persistence of electrical activity for periods ranging from 30 to 180 minutes[11]. The paper does not mention oxygenation or the use of asanguineous perfusion, only that perfusion pressure was maintained by “the addition of small increments of dextran or compatible donor blood.” Brain temperatures measured were between 30 degrees Celsius and 35 degrees Celsius. In 1964, White et al. reported persistence of electrical activity in the isolated brain being perfused with a complete mechanical extracorporeal system incorporating a small disk oxygenator[12]. The researchers observed increasing lactate and pyruvate (indicating developing acidosis) after 2 hours and cerebral edema after 3 hours. Electrocardiac activity gradually declined after 3.5 hours. In 1966, White et al. investigated refrigeration of the whole canine brain in vitro at ~2-3 degrees Celsius[13]. The blood in the brains was replaced by heparinized Ringer’s lactate solution. Brains that were stored up to 4 hours showed electrical activity after temperatures of 22 degrees Celsius or more were reached during reperfusion. Prolonged maintenance perfusion of the rewarmed brain exceeding 6 hours after hypothermic storage, however, resulted in the disappearance of electrical activity and irreversible edema. Most remarkably, White et al. report “excellent revascularization of the brain” during perfusion, even in the 2 brains that had been stored for 15 (!) days. They do report increased edema for brains with longer storage times, but this edema could be delayed and

temporarily offset by increasing the osmolality of the blood by adding urea. The latter observation has important consequences for the design of organ preservation solutions and cryoprotective carrier solutions in human cryopreservation. In 1972, White et al. reported persistence of electrical activity in isolated brains that underwent low flow asanguineous perfusion for 4 to 6 hours below 5 degrees Celsius[14].

These results indicate that the viability of the whole brain (as evidenced by recovery of electrical activity after rewarming) can be maintained for up to 4 hours after static cold storage and up to 6 hours after low flow asanguineous perfusion. Two important caveats are in order, however. Firstly, as reported by White et al. long-term persistence of electrical activity after long term ultraprofound storage appears to be a challenge. Secondly, isolated brain studies constitute somewhat of an “ideal” research model. And an additional caveat specific to cryonics is that the brain of a typical cryopatient is moderately to severely ischemic prior to hypothermic preservation. Having said this, the results by White et al. are consistent with the results (and limits) obtained in whole body ultraprofound asanguineous circulatory arrest and perfusion.

### *Normothermic Isolated Brain Perfusion*

Like conventional organ preservation, perfusion of the isolated brain is often done at hypothermic temperatures. The most important advantage is that the adverse effects of isolated perfusion will be mitigated by low temperatures. If the isolated brain is perfused for a prolonged period of time, damage to blood cells will lead to increasing hypoxia and impairment of circulation, with reduced viability as a result. Despite these limitations, the need for normothermic isolated brain perfusion models has been recognized. Normothermic isolated brain perfusion can be helpful when the specific effects of administration of a substance of the brain need to be studied without the interference of the rest of the body, and the action of other organs on the body, in particular. The model can also be used to investigate cerebral ischemia, the blood brain barrier (BBB), and the effects of different flow rates and energy substrates on the brain. Perfusing the brain at normal body temperature will eliminate the effects of cold on biochemical reactions and



specific effects of hypothermia. Currently, the challenges of warm isolated brain perfusion are addressed by using oxygen-carrying compounds such as perfluorocarbons in combination with synthetic buffers such as HEPES as the perfusate.

Although such models are of limited use in predicting what to expect in hypothermic organ preservation and whole body asanguineous ultraprofound hypothermia, let alone remote blood substitution of cryonics patients, they can be used to study specific phenomena and to screen agents for use in cryonics. Mukherji et al. review the use of this model to look at brain metabolism after administration of various compounds[15]. Some findings they present include the observation that mannose can completely substitute for glucose as the energy substrate, ethanol is not metabolized in the brain, and dimethyl sulphoxide (DMSO) increases the rate of glycolysis. Recent studies with isolated brain preparations have been used to investigate the preservation of the blood brain barrier and the molecular control of micro vessels. Such models could be particularly helpful in studying the (specific) toxicity of cryoprotectant agents and its effects on the vasculature of the brain.

### *Isolated Head Perfusion in Cryonics*

It should be noted that a related procedure to isolated perfusion of the brain that exists as a clinical procedure in cryonics is *isolated head perfusion*. To reduce (surgical) time and avoid injury to the brain, in cryonics the brain is left in its skull while it is being perfused with a vitrification agent. Isolated head perfusion offers several advantages to including the rest of the body (or upper body) during perfusion of the brain. The most obvious advantage is that cephalic isolation prior to cryoprotective perfusion reduces the time between start of surgery and start of cryoprotectant perfusion. This is especially beneficial in cases where the patient presents at relatively high body temperatures. A related advantage is that cannulating only the head does not require the additional step of clamping off the descending aorta and the extremities. Because most of the cross-section of the stump is available for venous drainage, isolated head perfusion should also present fewer pressure related complications during perfusion. Typically, central venous pressure tends to rise during the final stages of cryoprotectant perfusion, shunting a

portion of the perfusate through the (normally) higher resistance bridging veins. As a consequence, less burr-hole drainage and facial edema has been observed during isolated head perfusion.

## **Whole Body Hypothermic Resuscitation**

The gold standard for evaluating the efficacy of asanguineous ultraprofound hypothermia is the ability to resuscitate the person (or animal in a research) from a state of low-flow perfusion or specific periods of complete circulatory arrest. Being able to demonstrate this capability would provide evidence that the initial part of cryonics procedures—cooldown to low temperatures—just above zero degrees Celsius, is reversible with contemporary technologies. Because most cryonics patients will generally not be transported to a cryonics facility while undergoing hypothermic bypass, the most relevant research model is one of profound or ultra-profound whole body circulatory arrest. Induced deep hypothermic circulatory arrest is now routinely used in conventional medicine for procedures where the surgeon needs a motionless and bloodless field. Profound and ultra-profound (asanguineous) circulatory arrest are currently being investigated as a means to treat trauma victims and to protect the brain from injury after normothermic cardiac arrest.

Like in vitro hypothermic organ preservation, the length of time experimental animals can be held at low temperatures (sometimes close to the freezing point of water) depends on whether the blood is substituted with a suitable “global” whole body perfusate and whether the animal is in a state of complete circulatory arrest or receiving low flow perfusion. The current documented record for recovery from circulatory arrest without significant brain damage stands at 3.0 hours near 0°C in a canine model[16] . The current documented (but unpublished) record for recovery from low flow ultraprofound asanguineous hypothermia is 5 hours in a canine model[17].

These records seem to be consistent with the best results White et al. achieved for cold storage (up to 4 hours) and perfusion of the isolated brain (up to 6 hours), especially if one allows for the fact that the isolated brain model is the “ideal” research model and complete recovery of the experimental animals without adverse neurological effects constitutes a

stricter definition of successful resuscitation than demonstration of maintenance of electrical activity in the brain after 3.5 hours of circulatory arrest. Harris notes that if we estimate the equivalent normothermic ischemic time for a dog at 3.0 hours of circulatory arrest at temperatures just above the freezing point of water we find a value of ~10 minutes at normal body temperature[18]. Complete neurological recovery from 10 minutes of normothermic circulatory arrest can be reconciled with the current 5 minute limit for dogs and humans if we take into account a number of important differences between conventional normothermic resuscitation and asanguineous ultraprofound resuscitation.

Perhaps the most important difference is that the blood of the experimental animals was replaced with an “intracellular” solution that is designed to counter the adverse effects of hypothermia and ischemia. Such organ preservation solutions often contain agents that have neuroprotective properties such as glutathione and mannitol. Therefore, these models should be compared with models of normothermic resuscitation in which neuroprotective agents are administered. Darwin, Harris et al. were able to resuscitate dogs from more than 16 minutes of normothermic cardiac arrest employing an aggressive post-resuscitation drug protocol and management of hemodynamics[18]. Extrapolating these normothermic results to an equivalent time of circulatory arrest at temperatures close to zero degrees Celsius indicates that resuscitation from ultraprofound asanguineous circulatory arrest might be possible for up to 5 hours, provided the perfusate includes similar cerebroprotective agents as were used in the normothermic experiments of Darwin and Harris. Furthermore, the animals in the ultraprofound asanguineous circulatory arrest experiments may also benefit from the fact that they were kept cool for hours after the experiment. Such a protocol would mimic a model of normothermic circulatory arrest plus post-resuscitation hypothermia. In light of the observation that even very modest decreases of brain temperature can have a profound neuroprotective effect, the value of 2.2 for Q10 may be too conservative. For example, Nakashima et al. observed different temperature sensitivities for release of the neurotransmitters glutamate, aspartate, glycine, and GABA during cerebral ischemia[20]. Such findings may indicate that even longer periods of circulatory arrest at

hypothermic temperatures might be feasible. On the other hand, the rate of biophysical events (such as diffusion of water and ions) is not as affected by temperature as biochemical events, limiting the efficacy of hypothermia as the sole treatment prior to inducing circulatory arrest.

A number of observations about past and recent whole body hypothermic resuscitation studies in the context of cryonics are warranted. That the superiority of asanguineous perfusion or circulatory arrest over hemodiluted, let alone whole blood, is taken for granted in most of these studies is evidenced by the fact that it is hard to find studies that compare the outcome of non-asanguineous whole body hypothermic resuscitation to asanguineous resuscitation in terms of neurological behavior and histology. Although the assumption seems to be that the superiority of bloodless isolated organ preservation does not warrant such experiments, this state of affairs makes it difficult to compare asanguineous to non-asanguineous experiments. For example, the Alcor asanguineous ultraprofound hypothermia experiments solely consisted of a number of experiments using identical protocols and perfusate composition. In light of the fact that these experiments were conducted to improve technologies for remote stabilization of cryonics patients, the absence of any non-asanguineous controls results in reduced context, and a missed opportunity to elucidate the mechanisms of injury when the blood is left in the animal. More recent experiments by other groups also lack such controls. It is also worth mentioning that the current documented record of 3 hours for whole body hypothermic resuscitation did not involve complete blood substitution of the animals[21]. In addition, the successful hypothermic whole body resuscitation experiments in rats and hamsters that were conducted during the middle of the 20th century by researchers such as Smith and Andjus did not include blood substitution but were still effective in restoring full body recovery after more than 3 hours of ultra-profound cold ischemia. In an important paper, Sekaran et al. addressed the necessity of blood substitution in detail by comparing neurological recovery in a porcine model of ultraprofound hypothermic circulatory arrest[22]. The researchers divided the animals into one of three target hematocrits groups (0%, 5%, and 15%) during circulatory arrest and observed significantly better neurological recovery in the group that underwent complete blood replacement (hematocrit

0%). The authors also discuss a study in piglets[23] where the opposite was observed, but point out that the higher temperature in this study (15 degrees Celsius) may have avoided the deleterious effects on blood components that is observed when the temperature is dropped lower than 5 degrees Celsius. The Sekaran study strengthens the case for remote blood substitution in cryonics although two caveats are warranted. First, superior results obtained in bloodless ultraprofound hypothermia cannot be just extrapolated to cryonics patients, who typically have experienced significant ischemic injury prior and/or after legal death. Second, it remains to be investigated if the superior benefits of asanguineous ultraprofound hypothermia can be “mimicked” by pharmacological treatments without conducting blood substitution.

## **Composition of Whole Body Organ Preservation Solutions in Cryonics**

Before discussing the indications and contra-indications for remote blood substitution in cryonics, it will be helpful to briefly review the history and the composition of the organ preservation solution that is currently used in cryonics. This will not only set the stage for discussion of improved organ preservation solutions, it will also help with reconciling the experimental results obtained in whole body washout canine experiments and observations made during cryonics cases.

The current organ preservation solution used by cryonics organizations is called MHP-2. MHP-2 stands for Mannitol Hepes Perfusate number 2. MHP is a so-called “intracellular” organ preservation solution because its ionic composition mimics that of the cell to counter hypothermia-induced cell swelling. MHP itself was inspired by Gregory Fahy’s RPS-2, Renal Preservation Solution number 2. RPS (itself a modification of Euro-Collins solution) is a hyperkalemic intracellular organ preservation solution designed for hypothermic preservation of kidneys. The published formula for RPS-2 is: 7.2 mM K<sub>2</sub>HPO<sub>4</sub>; 5 mM reduced glutathione; 1mM adenine HCl; 180 mM dextrose; 28.2 mM KCl; 10 mM NaHCO<sub>3</sub>; 2 mM Ca<sup>2+</sup> and 1 mM Mg<sup>2+</sup>.

RPS-2 was modified to be used for asanguineous ultraprofound resuscitation. The most important changes include a substantial reduction of

glucose in favor of the impermeant osmotic agent mannitol because high concentrations of glucose produced severe acidosis during whole body hypothermic blood substitution. The other major change is the substitution of HEPES (N-2-Hydroxyethylpiperazine-N'-2-ethanesulfonic acid) for the phosphate based buffer. HEPES is compatible with higher pH's of the perfusate (which is deemed to be beneficial at lower hypothermic temperatures) and does not cause precipitation of calcium and magnesium salts. MHP also includes a colloid to counter development of edema during prolonged hypothermic perfusion. Michael Darwin and Jerry Leaf observed that other colloids produced edema in the lungs and pancreas (Dextran 40) and acute lesions in the liver ( polyvinylpyrrolidone: PVP). MHP was meant to be introduced with 1000 I.U. (International Units) of Heparin to prevent coagulation.

Although the qualitative differences between RPS-2 and the MHP based solutions are known, it has turned out to be a considerable challenge to reconstruct the “official” formulas for MHP and MHP-2. One reason for this is that various formulations have been published in Alcor's Cryonics magazine, the official write-up of the hypothermic canine experiments, and the Leaf & Darwin patent[24]. The preferred formulation in the patent and the July 1984 issue of Cryonics magazine agree on all the components, except for adenine and glutathione, which are omitted in the preferred formulation in the patent and the table that documents the composition of the total blood washout solution used in the canine experiments[25]. It can be assumed that the amounts for adenine and glutathione documented for MHP in the July 1984 issue of Cryonics magazine are identical to those in RPS-2. Whether these two components are part of the official formula of MHP depends on whether one takes the published formula in the magazine or the formula published in the canine experiments as the standard. Because the author has not been able to find an official announcement about MHP-2, its formulation can only be deduced by comparing the components and values for MHP with those for MHP-2 (as used in cryonics cases and experiments). The most fundamental change was the addition of D-ribose. No official announcement has been made to add D-ribose to Alcor's washout perfusate but the desire to modify the MHP perfusate to prevent development of skeletal and cardiac muscle rigor is

evident in the discussion of the 16th total blood washout canine experiment, in which a modified UW solution was used as a flush solution[26]. In a case report for the May 1989 issue of Cryonics magazine Mike Darwin states that “we also think it possible that the addition of phosphate and ribose to the flush perfusate resulted in better metabolic support to the muscles (and presumably neurons and other body cells) during the subsequent cold ischemia of air transport.” Presumably, for these reasons D-ribose is the additional component in MHP-2. Other changes include reductions in the amounts of adenine and glutathione, a (further) decrease of the amount of glucose by 50%, and doubling of the concentration of HEPES. Unlike the original MHP patent and the total body blood washout article, published formulas of MHP-2 also include insulin. The rationale for insulin (and other remaining uncertainties) in cryonics organ preservation solutions will be discussed in more detail below. No documented attempts to improve upon MHP-2 exist since this statement of almost 25 years ago.

A comparison between the RPS-2, MHP, and MHP-2 can be found in the table below:

	<b>RPS-2</b>	<b>MHP</b>	<b>MHP-2</b>
Mannitol	-	170 mM	170 mM
Adenine-HCL	1 mM	(1 mM)	0.94 mM
D-ribose	-	-	0.94 mM
Sodium bicarbonate	10 mM	10 mM	10 mM
Potassium phosphate	7.2 mM	-	-
Potassium chloride	28.2 mM	28.3 mM	28.3 mM
Calcium chloride	1 mM	1 mM	1 mM
Magnesium chloride	2 mM	1 mM	1 mM
HEPES	-	7.2 mM	15 mM

Glutathione	5 mM	(5 mM)	3 mM
D-Glucose (Dextrose)	180 mM	10 mM	5 mM
Hydroxyethyl starch	-	50 g per L	50 g per L
Heparin	-	1000 I.U. per L	1000 I.U. per L
Insulin	-	-	40 I.U. per L
Osmolality	280-290 mOsm	388-403 mOsm	388-403 mOsm
pH	7.4	8.0-8.2	8.0-8.2

## **Logistical and Technical Aspects of Total Body Washout**

The most important reasons to question the practice of remote blood substitution (prior to transport) in cryonics are concerns about the effect of blood washout in ischemic patients and the alternative of conducting field cryoprotection instead. In a number of cases, (cerebral) edema has been observed in patients whose blood was replaced with an organ preservation prior to cold transport. As will be discussed below, at the Cryonics Institute, research by Yuri Pichugin did not find better viability in brain slices that were preserved in an organ preservation vs. brain slices that were preserved in whole blood. These results seemed to be consistent with the results by White et al. that it is not likely that brains can be kept viable for periods exceeding 4 hours of cold storage. Additional concerns about the lack of proper equipment at funeral homes and reperfusion injury contributed to the decision at the Cryonics Institute not to do remote blood substitution for cases in which the patient does not receive rapid stabilization. However Advanced Neural Biosciences, Inc. (ANB) has done research that found improved cryoprotectant perfusion of rat brains after up to 48 hours of cold storage following blood washout with MHP-2 compared to rats to which only anticoagulants were administered. Before we address the topic of reperfusion



injury a number of other reasons for forgoing remote blood substitution are briefly mentioned.

### *Logistical Reasons to Forego Remote Blood Substitution*

There can be cryonics scenarios that warrant skipping remote blood substitution although the expertise and equipment is available. For example, the cryonics standby team can significantly reduce transport time by preparing the patient for cold transport instead of adding the extra step of blood substitution. In such cases the standby team is confronted with the choice of doing remote blood substitution at the expense of catching the next airplane for shipping the patient. In case there are regular flights, this can be a difficult trade-off, but in case the next flight is not scheduled for, let us say, the next 48 hours, it would be more prudent to give priority to getting the patient to the cryonics facility for cryoprotectant perfusion promptly. Another example is when the cryonics organization has been able to find a nearby cooperating funeral home for preparation of the patient but blood substitution is not possible or is not permitted at the facilities. In such cases, the standby team has to either forgo blood substitution or expose the patient to longer cardiopulmonary support transport times during transport to another, more distant, funeral home. Such a scenario occurred with Cryonics Institute Patient #81.

### *Technical Reasons to Forego Remote Blood Substitution*

Perhaps with the exception of closed circuit cryoprotective perfusion, remote blood washout is one of the most challenging interventions in cryonics. Remote blood substitution requires two distinct medical skills: surgery and perfusion. Although cryonics organizations are often able to persuade funeral directors to use their professional skills to obtain access and cannulate the vessels, the lack of people with extensive knowledge about extracorporeal perfusion, let alone documented experience and skills, presents a major challenge for cryonics organizations. Unlike other interventions, such as placing an intravenous (or intraosseous) catheter or external cooling, extracorporeal perfusion of the patient can have serious negative consequences for the patient if mistakes are made. Examples of such mistakes

include the pumping of air into the patient, excessive perfusion pressure (vessel damage), and incorrect connection of the perfusion circuit to the patient's vessels (such as connecting the arterial side of the perfusion circuit to the venous side of the patient). The case report of Cryonics Institute Patient #81 generated a lot of discussion about what the necessary technical and professional requirements should be to operate the air transportable perfusion circuit (ATP), and there is a growing consensus that increased effort should be made to secure the assistance of professional perfusionists and facilitate more extensive training for existing cryonics team members. In the absence of people who have demonstrated skills to do perfusion, a decision to do remote blood washout for the patient should not be made lightly. For this reason, since 2011 Alcor has had a policy using the contractor Suspended Animation, Inc., (SAI) to perform blood substitution of Alcor patients in the continental United States outside of Arizona. SAI in turn contracts with cardiothoracic surgeons and clinical perfusionists, who are medical experts in accessing large blood vessels and diluting or replacing blood.

### *Errors in Perfusate Composition*

Although the composition of MHP-2 has been defined and stable through most of the 21st century, there have been historical inconsistencies. One of the most problematic has been anecdotal claims that during the 1980s MHP-2 was originally prepared by mixing ingredients in defined proportions, but not defined absolute concentrations. Final absolute concentrations were the result of titrating the ingredient mixture with water to achieve a measured target tonicity of approximately 400 mOsm, with a substantial portion of this tonicity due to undefined NaCl content of the HES powder then used. MHP-2 is currently prepared according to defined absolute amounts of each ingredient. If made correctly, it will have a measured tonicity using a freezing point osmometer of approximately 320 mOsm. Instead of an endpoint that is always achieved, tonicity is now a quality control check for stoichiometry errors.

Errors in circulating formulas of MHP-2 and mistakes made during perfusate preparation can also lead to adverse effects during blood substitution, ranging from slight diversions from optimal perfusate composition to major consequences such as decreased viability and increased

edema. Mistakes that have been made in perfusate preparation in cryonics include elimination of sodium bicarbonate (under the assumption that the change from MHP to MHP-2 was to substitute HEPES for sodium bicarbonate), errors in stoichiometry in case of components that are supplied in hydrated versions, incorrectly low concentrations of calcium-chloride, and preparation of the solution with physiological pH (7.4) instead of the higher pH range that (8.0-8.2).

Some formulations of MHP-2 include insulin in the same amount as Viaspan (40 I.U. per liter). The question of whether to add insulin to MHP-2 remains unresolved. Some cryonics advisors believe that there is no evidence that this component is essential for asanguineous hypothermic resuscitation, and may even be detrimental. Other cryonics advisors believe that it may be essential to support non-neural glucose metabolism (particularly in the 5 to 15 degrees Celsius range) and to prevent rigor mortis in heart and skeleton muscles by facilitating glucose entry through the GLUT4 transporter.

MHP-2 includes the antioxidant tripeptide glutathione to scavenge free radicals. Because glutathione oxidizes during prolonged storage, it is generally agreed that it would be better to add glutathione at the last minute during a case. Before this can be accomplished a number of challenges need to be overcome: the glutathione needs to be kept chilled during transport, a practical method of introducing it to the solution must be found, an undesirable drop in final pH (glutathione is acidic) needs to be avoided, and addition of the glutathione in the field should not increase osmolality excessively. Similarly, concerns have also been raised about long term degradation of heparin in MHP2. Although it has occasionally been advised that polypeptides like glutathione and glycosaminoglycans like heparin should be added during use, current practice in cryonics has been to add them during perfusate preparation.

Because the challenges discussed here can be overcome by improvements in perfusate preparation and better quality controls, these problems do not reflect deficiencies in the formulation and use of the perfusate itself. This still leaves the question of whether remote blood washout can aggravate injury in ischemic patients unanswered. Dr. Southard, one of the inventors of Viaspan (UW solution), discussed similar concerns in a recent interview about the future of organ preservation solutions:

In clinical organ preservation/transplantation, there are many unexplained incidents of reperfusion injury. This is characterized by delayed graft function in the liver and kidney. We do not see this in our animal models. Thus, there are some differences between how experimental animals and human donor organs respond to organ preservation. The difference may be related to the fact that the UW solution was developed to preserve the “ideal organ.” This is one taken from a relatively young and healthy lab animal donor and transplanted into a healthy recipient. In the clinics, the donors are usually brain-dead (brain trauma), remain in the ICU for periods up to a day or more, are treated for hypotension, and come from an uncontrolled group of donors. Therefore, we are now studying how UW solution preserves organs from the “less-than-ideal” donor. We are simulating the clinical condition by inducing warm ischemia or brain death in experimental animals to determine if UW solution is suitable for these types of organs. If not, we will develop an ideal method to preserve these less-than-ideal donor organs.[27]

## **Reperfusion injury**

### *The No-Reflow Phenomenon*

In a landmark 1968 study[28], Ames III et al. introduced the phenomenon of “no-reflow,” the observation of impaired blood flow after ischemia. The no-reflow phenomenon is treated separately from reperfusion injury for two reasons. The most important reason is that although cerebral ischemia-induced “no-reflow” may reflect brain injury, impaired flow itself does not constitute injury and can be (partially) reversed by specific interventions such as hypertension and hemodilution. The other reason is that most explanations that have been put forward for the no-reflow phenomenon such as post-ischemic hypotension, increased blood viscosity, blood coagulation, plugging of vessels by inflammatory blood components, and cell swelling, can all be mitigated by washing out the blood with an hyper-osmolar organ preservation solution and increased perfusion pressure. Instead of contributing to or aggravating post-ischemic no-reflow, remote extracorporeal perfusion seems to be the ideal intervention to reverse no-reflow and restore flow to regions of the brain that had been previously closed off by ischemia. The ability to vastly

improve cooling rates during extracorporeal perfusion can also delay ischemic depolarization and ischemia-induced cell swelling.

There are two ways remote blood substitution *may* produce adverse effects similar to no-reflow. If the patient has been in circulatory arrest for an extended period, reintroduction of oxygen may introduce free radical injury to cell membranes, and consequently, impaired perfusion. To the extent that there is merit to this scenario this might be avoided by “anoxic blood substitution” and inclusion of antioxidants and free radical scavengers in the organ preservation solution. The second way in which blood substitution may produce adverse effects similar to no-reflow is that if the composition of the organ preservation solution itself is of such a nature that some components will contribute to edema and impaired flow. This is especially a concern in case when edema would *exceed* what we would expect with leaving the blood in the patient during cold transport. This issue is not intrinsic to blood substitution as such but raises important challenges in terms of perfusate formulation. We will address this concern in more detail when we discuss potential improvements to perfusate composition for use in prolonged static use.

The reason to focus on reperfusion injury *induced* by blood substitution instead of ischemic injury resulting from cold circulatory arrest is because the ischemic injury that one would expect during prolonged periods of asanguineous circulatory arrest should occur equally or even more so during cold circulatory arrest in patients whose blood has not been washed out. Moreover, it is the very ability to manipulate the composition of the intracellular and extracellular environment in asanguineous cold circulatory arrest that permits longer maintenance of viability. Therefore, it is more instructive to look for instances where *the process of blood substitution itself* may produce or aggravate ischemic injury.

### *Free Radical Injury*

There are at least three scenarios in cryonics in which blood substitution could produce or aggravate free radical injury:

1. Prolonged circulatory arrest without stabilization

2. Trickle flow perfusion during cardiopulmonary support

3. Intermittent perfusion during surgery prior to blood substitution

In the first scenario, the patient has suffered a long period of normothermic ischemia before or after pronouncement of legal death. Although there has never been a rigorous attempt to quantify the maximum period of warm ischemia that a cryonics patient can be exposed to beyond which restarting circulation does more harm than good, it is usually recommended not to oxygenate the patient during cardiopulmonary support after 30 minutes of circulatory arrest. When a patient has been without circulation for a long period, remote blood substitution is sometimes forgone altogether. In case circulatory arrest is immediately followed by blood substitution, free radical injury can take two forms: 1) when the perfusate is not oxygenated, dissolved oxygen in the perfusate and remaining oxygen in the patient's vessels can cause free radical-mediated reperfusion injury, and 2) when the perfusate is oxygenated, additional oxygen will be introduced to the patient and may cause additional free radical injury if the oxygen cannot be metabolized before contributing to free radical formation.

It should be noted that the first scenario cannot be completely avoided. Even if the perfusate itself would not contain any dissolved oxygen, some residual oxygen in the vessels of the patient would be introduced to the ischemic brain. This would be even the case if the patient were perfused with an inert gas because the initial perfusate that enters the patient will move the remaining oxygenated blood to the brain. Since generation of harmful reactive oxygen (and nitrogen) species is virtually instantaneous upon reperfusion it is doubtful if such initial events of reperfusion injury can be completely avoided during restoration of circulation in ischemic patients. The question therefore is whether such reperfusion injury is worse than leaving the blood in the patient and accepting slower cooling rates. It cannot be argued that circulation is going to be restored during cryoprotective perfusion at any rate, so remote blood substitution will only produce this injury at an earlier stage. For starters, when blood substitution is being eliminated the patient will typically be shipped at water ice temperature. As a result, cryoprotective perfusion will start around the freezing point of water, which may reduce free

radical injury. Further, if remote blood substitution is performed, the patient will go through two separate cycles of circulatory arrest and reperfusion. Reperfusion injury caused during the first cycle of perfusion may worsen the prospects for subsequent perfusion with a vitrification agent as a result of increased edema and cell membrane damage. On the other hand, by removing the blood, blood components that can contribute to impairment of cryoprotectant perfusion (such as platelets, red blood cells, and white blood cells) will be removed from the circulatory system of the patient. Although it is possible to outline the potential advantages and disadvantages of remote blood washout in patients with long periods of circulatory arrest, it will not be possible to make any specific, let alone quantitative recommendations unless such cryonics scenarios are investigated in a relevant research model (see below)

The second scenario in which reperfusion injury may present a problem is when a patient undergoes prolonged periods of low-flow cardiopulmonary support. The assumption is that cerebral blood flow will not be sufficient to meet cerebral oxygen demand but will be adequate to cause free-radical mediated injury. There are three arguments against this scenario. The first is that such low-flow states are better than no flow at all. Steen et al. found that dogs could sustain only 8 to 9 minutes of complete ischemia but 10 to 12 minutes of incomplete ischemia (cerebral blood flow less than 10% of control) without neurological impairment[29]. The second is that instead of being adverse, such low flow states may mitigate reperfusion injury because they “stabilize” ischemic injury that occurred during circulatory arrest and simultaneously reduce reperfusion injury during full restoration of circulation by cardiopulmonary bypass through post-ischemic conditioning and up-regulating antioxidant defenses[30]. The third is that prolonged low flow perfusion will induce hypothermia (albeit less rapidly than would have been possible during aggressive cardiopulmonary support). Because decreased body temperatures will mitigate ischemic injury (and thus free radical damage), at some point the combination of low flow blood flow and hypothermia may eliminate ischemic injury.

Since there can be enormous variability in the quality of treatment during both short and prolonged periods of cardiopulmonary support, it is difficult to

make any firm recommendations about which events during cardiopulmonary support are indications, and which are contra-indications, for blood substitution. It can be argued, however, that because cryonics stabilization medications contain a number of antioxidants and free radical scavengers, there appears to be less risk of inducing major reperfusion injury by following cardiopulmonary support with cardiopulmonary bypass, especially when the patient is at low temperatures and periods of halted blood flow will be minimized during surgical preparation for blood substitution. If additional ischemic injury is incurred during cardiopulmonary support, this scenario resembles the first scenario in which blood substitution is performed in a patient with prolonged circulatory arrest, although we would expect different mechanisms of injury during prolonged cardiopulmonary support such as pulmonary edema and increased free radical damage. So far the relationship between various forms and durations of cardiopulmonary support and its effects on subsequent blood substitution has not been the subject of focused research in cryonics.

The third scenario is one in which long interruptions or intermittent interruptions in chest compressions during surgery increases reperfusion injury during blood substitution. This concern is more relevant than it was in the earlier days of cryonics when focused attempts were made to minimize interruptions of cardiopulmonary support during surgery. It is not a-priori clear whether complete interruption of chest compressions during surgery or intermittent interruptions are more harmful. The latter scenario may be more harmful because it allows for continuous cycles of free radical generation. Although cardiopulmonary bypass can induce more rapid cooling than external cooling, it seems not advisable to do surgery at near normothermic temperatures. Such a scenario would mimic a clinical situation in which circulatory arrest would be produced at mild hypothermic temperatures. When more advanced cooling techniques like cold cyclic lung lavage (liquid ventilation) will become available in cryonics, the option of delaying surgery until a “safe” temperature is reached should come within reach. Ischemic injury and reperfusion injury induced by interruptions in circulation during surgery will rarely be an argument to forgo blood substitution because the decision to do surgery reflects a decision to wash out the patient’s blood.



Only during exceptional circumstances may observations made during surgery present a reason to terminate further attempts at blood washout. The most obvious example is when the surgeon believes the patient's circulatory system is in such a poor state that it should not be further damaged until cryoprotective perfusion in the cryonics facility.

### *Calcium Overload*

Reperfusion injury is not confined to reoxygenation injury. One of the major mechanisms of injury during cerebral ischemia is calcium-induced cell death. Intracellular calcium overload is produced by a number of mechanisms including excitotoxicity, inhibition of ATP driven membrane pumps, and generation of free radicals. Intracellular calcium overload can be aggravated by restoring circulation, either through closed chest cardiopulmonary support or cardiopulmonary bypass. As such, the opportunities for increased calcium-induced injury are similar to those for free radical injury. Even when the stabilization medications protocol includes agents that chelate calcium such as citrate or EDTA, restoration of circulation can still contribute to delivering extra calcium to ischemic cells during the early stages of perfusion. The analogy between free radical injury and calcium overload induced reperfusion injury is not complete. Whereas the patient remains at risk of free radical induced injury during all parts of cryonics procedures, increasing calcium overload is only a major risk during cardiopulmonary support when calcium has not been chelated by citrate. Cardiopulmonary bypass also allows for manipulation of the patient's extracellular and intracellular environment which can be used to reduce calcium induced cell injury.

### *Vascular Injury*

Perhaps the biggest concern about following prolonged periods of cardiopulmonary support with cardiopulmonary bypass is that this introduces another opportunity to produce or aggravate injury to (micro)vessels. As discussed earlier, such injury can be produced by inexperienced persons running perfusion equipment. This can be avoided by employing professional stabilization teams and skilled perfusionists. But it is also conceivable that cardiopulmonary bypass will invariably worsen the state of the circulatory

system in patients with (advanced) ischemic injury. Such injury can be produced by free radicals, calcium overload and other mechanisms such as neutrophils and platelets (or a combination of those factors) and aggravated by restoring circulation at high temperatures. This last possibility highlights the reason why this concern cannot be dismissed by stating that a patient needs to be perfused with a cryoprotective agent requires circulation at any rate. First, the temperatures at which patients are typically perfused with a cryoprotective agent are lower than those at which remote blood substitution is initiated. As such, biochemical reactions that can worsen vascular injury happen at a faster pace during blood washout. Second, total perfusion times for patients whose blood is replaced with an organ preservation solution is longer because a) the organ preservation solution needs to be washed out again, and b) during blood substitution, “closed circuit” recirculation of the perfusate is often necessary to approach the freezing point of water prior to air transport of the patient. Although edema produced during blood substitution may be reversed during cryoprotective perfusion by circulating a hyper-osmotic / hyper-tonic perfusate, such measures increase cryoprotective perfusion times and risk additional injury to cells and the blood brain barrier as a result of the alternating osmotic fluid cycles between cells and the patient’s vessels.

Although there are a number of clinical arguments to replace the patient’s blood with an organ preservation solution for transport at ultra-profound temperatures, we know that blood itself is not harmful to (non-ischemic) vascular cells. How ischemic vessels respond to long storage times with an a-cellular asanguineous perfusate is still mostly unexplored territory. As will be discussed in the section about improvements to perfusate composition below, vascular injury during perfusion may be mitigated by including components that can “seal” damaged membranes, allowing for longer perfusion and transport times without edema.

## **Contra-Indications for Remote Blood Substitution**

The lack of validation of blood substitution in models that reflect the typical cryonics transport situation makes it difficult to formulate a set of hard indications and contra-indications for remote blood substitution.

The **indications** for remote blood substitution are roughly equivalent to what constitutes a good cryonics case: patients who received prompt intervention after pronouncement of legal death, aggressive cardiopulmonary support, and minimum interruptions of circulation prior to blood washout resulting in reduced ischemic injury and rapid cooling. In qualitative terms, in such cases, near-physiological circulation is achieved after cardiac arrest and cardiopulmonary bypass will constitute a continuum of this.

The **contra-indications** for remote blood substitution range from “pre-mortem” patient pathologies to practical and logistical challenges. What follows is a list of contra-indications derived from the discussion above.

- Omitting remote blood substitution will significantly reduce transport time
- The nearest funeral home that allows blood substitution will result in excessive cardiopulmonary support times
- No team members with extensive experience and knowledge of cardiopulmonary bypass are present on the case
- Inspection of the blood organ preservation solution finds bacterial growth
- Inspection of the blood organ preservation solution composition finds serious errors in perfusate composition
- Observations of systemic edema during cardiopulmonary support
- Active gastrointestinal bleeding at the time of cardiac arrest
- Prolonged splanchnic ischemia or severe abdominal swelling
- Severe pulmonary edema
- Severe cerebral edema
- Prolonged periods of warm cerebral ischemia (>60 minutes)

As the last contra-indication indicates, sometimes there may be arguments to forgo blood substitution when the risks may not be visible yet. In cases of prolonged warm circulatory arrest, initiating cardiopulmonary bypass may produce fulminating cerebral edema. As a result, the only opportunity to perfuse the brain will be “used up” during blood substitution instead cryoprotective perfusion.

## **Improved Organ Preservation Solutions for Cryonics**

As experimental studies of static storage of brains and clinical limitations of static storage of organs with similar tolerance to ATP deprivation (such as the heart) indicate, it is not likely that remote blood substitution can secure viability of the brain during typical cryonics transport times, often exceeding 24 hours. This does not mean that remote blood substitution is contra-indicated for long transport times because there are a number of other advantages to remote blood substitution. Unless fundamental breakthroughs in hypothermic organ preservation solution design are made that allow substantial extension of cold hypothermic storage of the brain, more emphasis on designing solutions that prevent development of edema during transport seems to be the most promising research direction. Another interesting research area is to use some of the findings of the normothermic resuscitation experiment for improved composition of organ preservation solutions. An obvious example would be to include neuroprotective additives to the perfusate to extend tolerance to cold ischemia. This direction is further warranted by the fact that during remote blood substitution most of neuroprotective medications are flushed out.

### *Protecting Against Hypothermia and Ischemia-Induced Edema*

The major concern that has been raised about MHP-2 is that blood substitution may have the unintended result of increasing edema during cold storage, instead of decreasing it. Reasons why this could happen have been discussed earlier in the text: lack of hyper-osmolality (or even hypo-osmolality) or cardiopulmonary bypass in (very) ischemic patients. Another reason may be that some of the “impermeants” like glucose and mannitol will cross cell

membranes and increase intracellular water accumulation. One modification in MHP-2, especially in light of its use during prolonged transport times, would be to substitute higher molecular weight impermeants like raffinose (594 mW) and lactobionic acid (mW) for glucose and mannitol. The new organ preservation solution by 21st Century Medicine (21CM) called TransSend contains the impermeants polyglycerol (which is the ice blocker Z-1000 used in 21CM vitrification solutions) and alpha-lactose.

### *Colloids*

The importance of the colloid hydroxyethyl starch in MHP-2 needs to be questioned in light of the fact that MHP-2 is almost invariably used for long cold transport instead of continuous low flow hypothermic perfusion. Concerns have been raised about HES effects on the viscosity of solutions and red blood cell (RBC) aggregation. Recent research into cold organ preservation indicates that the initial washout of organs can be optimized by using an HES-free solution with a non-RBC-aggregating colloid as the first step. Current cryonics protocols do not include such a two-step approach. Newer cold organ preservation solutions from 21st Century Medicine such as TransSend do not contain HES at all. An alternative for HES may be polyethylene glycol (PEG). Improved results have been found in solutions in which PEG is substituted for HES. Another advantage that PEG may have over other colloids is its ability to “seal” injured membranes, allowing for reduced cell damage and improved cryoprotective perfusion. Another membrane sealing polymer is the large molecular weight tri-block polymer Poloxamer 188 (P188). P188 is effective in much lower concentrations than PEG and has been shown to protect hippocampal neurons against neurotoxin-induced cell membrane damage[31] .

### *Energy Substrates*

MHP-2 includes adenine and D-ribose to assist regeneration of ATP during reperfusion. Because organ preservation solutions in cryonics are not used with the objective of near-term resuscitation, it is not evident that these components are of value during cold transport of the patient. On the other hand, providing energy substrates during cold storage may support the

remaining cellular metabolism during hypothermic transport. Such components may be especially important if the solution is not used as a static solution but for continuous or low-flow perfusion. Although UW solution does not include any glucose at all, low amounts of glucose have been maintained in MHP-2 to support anaerobic respiration and inhibit rigor during cold ischemia. Because of concerns about glucose-induced cell swelling and production of lactate accumulation, an alternative would be to substitute an alternative energy substrate for glucose.

### *Neuroprotective Agents*

Theoretical considerations would predict that the inclusion of neuroprotective agents in organ preservation solutions should be able to extend the period that the brain can tolerate cold ischemic exposure. The ability to resuscitate dogs from 3 hours of ultraprofound hypothermic circulatory arrest without blood substitution would suggest that these times can be extended if organ preservation solutions are designed to mitigate cerebral ischemia. Such solutions will not only include components to reduce hypothermia-induced cell swelling and acidosis but also agents to intervene in various parts of the ischemic cascade. Because warm ischemia is not equivalent to cold ischemia, it cannot be assumed that just adding all (or most) of the compounds that enable resuscitation from ~16 minutes of cardiac arrest will produce a comparable increase in preservation time during ultraprofound hypothermia, although such compounds should have priority in screening different formulations of organ preservation solutions. Some candidates for inclusion in improved organ preservation solutions are Tempol, FK-506 (Tacrolimus), Na<sup>+</sup>/H<sup>+</sup> exchangers inhibitors, and increased magnesium concentrations.

## **Research into Remote Blood Substitution in Cryonics**

Although blood substitution is routine in remote cryonics cases (or should be routine), the only documented evidence for its efficacy was done in the 1980s by Leaf and Darwin, and some pilot experiments by Leaf in 1970s. These experiments demonstrated that dogs could be resuscitated from up to 5 hours of low flow asanguineous ultra-profound hypothermia. Other experiments

with MHP (or variants thereof) have been done, but these experiments have not been (formally) documented. As a consequence, most of the rationale for using such organ preservation solutions has been based on extrapolation and theoretical considerations.

In 2005, Yuri Pichugin at the Cryonics Institute used the K<sup>+</sup>/Na<sup>+</sup> ratio assay to investigate viability of rat brain slices after various durations of warm and/or cold ischemia. He found that brain slice viability was 43% for 24 hours of cold ischemia, 0% for 48 hours of cold ischemia, 63% for 10 minutes of warm ischemia plus 6 hours of cold ischemia, and 32% for 1 hour of warm ischemia plus 23 hours of cold ischemia[32]. The author also reports that he did not find any improvements in brain viability when whole rat brains were perfused with “Viaspan (University of Wisconsin organ preservation solution), RPS-2(Renal Preservation Solution) and its modifications, MHP-2 (Mannitol - Hydroxyethyl starch – Perfusion solution; M. Darwin and et al, Alcor), Renasol H (Renal Solution with Hydroxyethyl starch; Dr. Fahy and et al, 21 CM), and New Organ Preservation Solution of Kyoto University (Chen F. and et al, Japan, 2004),” prior to 12 or 24 hours of cold storage at 4 degrees Celsius. Neither did any other compound used to prolong cold storage times offered great promise. In 2006 and 2007, Pichugin experimented with dehydration, inert fluids with silica gel, and non-toxic concentrations of aldehydes to stabilize cell membranes to improve viability during cold storage but did not observe encouraging results. He did report “stable vitrification” for sheep brains that were perfused after 24 hours of cold ischemia. These results seems to be at odds with the profound ultrastructural damage Mike Darwin, Jerry Leaf and Hugh Hixon (1982-1983) observed when ischemic cats were perfused with glycerol after 30 minutes of warm ischemia and 24 hours of cold ischemia. The investigators did not investigate viability but histological and ultrastructural changes between non-ischemic and ischemic cats after perfusion with glycerol, freezing and rewarming. Impaired blood washout, cerebral edema, and profound ultrastructural freezing damage was observed in the ischemic animals[33]. It should be noted that the animal model, the nature of ischemic exposure in these experiments (cold vs. warm plus cold), and the cryoprotectant used was not identical to Pichugin’s model. Also, the research

by Darwin, Leaf, and Hixon is the only documented research to date that studied the effect of ischemia and cold ischemia on cryoprotective perfusion.

In 2007, Gregory Fahy reported the results of hypothermic brain preservation that was done at 21st Century Medicine. Initially, the researchers found massive ultrastructural damage in brains that had been stored cold for 24 hours. But better results were obtained when perfusion pressure was raised during fixation from 60 mmHg to 120 mmHg, which seem to indicate that the initial results were a fixation artifact. In another series of experiments, 3 hours of static cold storage (which reflects the current record in total body washout) and 5 hours of continuous hypothermic perfusion were compared. K<sup>+</sup>/Na<sup>+</sup> assays on isolated hippocampal slices demonstrated better results for 5 hours of continuous perfusion, with viability scores not dropping for the duration of the experiment. Although continuous perfusion was demonstrated to be superior to cold static storage of brains, this achievement did vary, depending on the composition of the “brain preservation solution.” One preservation solution did not produce better results during continuous perfusion over static cold storage. This finding seems to support the view that the formulation of the organ preservation solution can affect cerebral viability during hypothermic perfusion. The researchers also demonstrated improved maintenance of electrical activity in the brain after continuous perfusion, although on this measure of viability, electrical activity dropped during the duration of perfusion, which seems to be consistent with the hypothermic brain preservation experiments of White et al.

Since 2008 Advanced Neural Biosciences has conducted extensive series of rat experiments to investigate the effects of ischemia and blood substitution on perfusion of the brain, cryoprotectant distribution, and ice formation. The most meaningful finding (and corroboration of Alcor’s protocol to do remote blood substitution) is that up to at least 48 hours of cold ischemia, blood substitution with an organ preservation allows for improved cryoprotectant perfusion and decreased ice formation. It was found, however, that the composition of the organ preservation solutions is important. There was little difference in case the blood was replaced with sodium chloride, better results were obtained with RPS-2, and the best results were observed in the case of Alcor’s MHP-2. The tentative conclusion to be drawn from this is that remote



blood substitution may not be effective in keeping the brain viable for more than 4 hours but that this procedure is still warranted up to at least 48 hours of cold ischemia (without substantial warm ischemia) to improve post-transport cryoprotective perfusion. Despite these beneficial effects researchers at Advanced Neural Biosciences have not been able to identify an organ preservation solution (including newer “brain preservation solutions) that decreases edema during post-transport cryoprotective perfusion.

In another series of experiments Advanced Neural Biosciences has investigated whether conducting blood substitution after various periods of warm ischemia is contra-indicated because it may only introduce additional damage as a result of “reperfusion injury.” In these experiments the researchers found, however, that following periods of warm ischemia by blood substitution is always better than not removing the blood prior to cold storage, up to 1 hour of warm ischemia, after which extensive ice formation was observed in both protocols. The tentative conclusions that can be drawn from these preliminary studies is that episodes of warm ischemia do not undermine the case for remote blood substitution but if these episodes are extensive (exceeding 1 hour) this procedure cannot be expected to reverse the negative effects of warm ischemia.

## **The Future of Blood Substitution and Field Cryoprotection**

Even under ideal circumstances, contemporary technologies do not allow functional recovery of the brain from more than 3 hours of circulatory arrest, or 5 hours of low flow perfusion. In addition, energy-depletion during prolonged cold storage contributes to edema. This raises the question whether there are credible alternatives for existing remote blood washout procedures. The two major alternative solutions identified are doing continues perfusion during transport and eliminating remote blood substitution and shipping on water ice for “field cryoprotection.”

The advantage of low-flow continuous perfusion would be the ability to keep the brain viable for a longer period of time en-route to the cryonics facility. There are a number of challenges with this approach. The typical transport times of patient that are pronounced legally dead in a remote location

will usually exceed the period in which it is still possible to maintain viability of the brain. As a consequence, this procedure will still fall short of Alcor's goal to secure viability of the brain by contemporary criteria. Another complication is that most Alcor patients will suffer some degree of ischemic injury pre- and/or post-pronouncement. Conducting low-flow continuous (or intermittent) perfusion on such patient can produce increasing (whole body) edema en-route to the facility. This is not just a detrimental development by itself but can also limit meaningful cryoprotective perfusion the operating room. Another complication that needs to be mentioned here is logistical. Even more than "conventional" static remote blood substitution, continuous perfusion of the patient requires the use of designated vehicle that is equipped to support the patient all the way from the start of washout until arrival at the facility. This would also require the non-stop presence of (professional) perfusionists.

A more realistic alternative that can both satisfy the aim of keeping the brain viable by contemporary criteria and prevent the edema that is typically associated with remote blood washout (and even continuous perfusion) is "field cryoprotection." In field cryoprotection the remote blood washout procedure is not followed by packing the patient in ice for shipping but cryoprotective perfusion and shipping on dry ice. One major advantage of this procedure is that most circuits that are being used for remote blood washout can also be used for step-wise cryoprotective perfusion. The topic of field cryoprotection will be briefly discussed again in the following section on the conduct of blood washout and will be more extensively treated in the chapter on cryoprotective perfusion.

## **Part 2**

### **Extracorporeal Perfusion in Cryonics**

While it can be argued that the practice of cryonics in the early days “straddled cryobiology and mortuary practice” the possibility (and desirability) of using mainstream medical extracorporeal technologies was already recognized by Robert Ettinger in his seminal cryonics book “The Prospect of Immortality.” He writes, “With fully adequate preparation, equipment, and personnel, the cooling phase seems to present little problem in most cases. Heartlung machines and heat exchangers are available at many hospitals. The cardiopulmonary bypass technique is commonly used for open-heart surgery, with cooling of the blood and body from the normal of about 38°C down to 20°C, and sometimes lower; this technique has been described, for example, by Sealy and co-workers. Apparently it could also be used, depending on the cause of death and opportunity for preparation, to cool freshly dead bodies quickly and safely, with no damage to the brain.” Following this observation, between 1966 and 1967 Dr. Dante Brunol wrote a protocol for the cryopreservation of cryonics patients that included closed chest compressions, the use of extracorporeal technology for cooling, blood washout, and cryoprotective perfusion.

Until at least the early seventies, however, the utilization of mainstream medical procedures and extracorporeal technologies for cooling, blood washout, and cryoprotective perfusion was not well developed and most cases were either conducted in funeral homes with (crude) embalmer’s equipment or cryonics patients just received a “straight freeze.”

This situation changed when Fred and Linda Chamberlain recognized the desirability of using mainstream extracorporeal technologies for cryonics patients and collaborated with Michael G. Darwin on a perfusion machine for cryonics patients. At the end of the 1970’s thoracic research surgeon Jerry Leaf entered the field and extracorporeal medical technology was incorporated

in cryonics protocols and adapted for use in cryonics patients. Despite (sometimes turbulent) changes in the field of cryonics, medical extracorporeal technologies have been remained a part of Alcor's procedures until the present day.

The use of extracorporeal technologies in cryonics is three-fold. It is used for remote blood washout, for cryoprotective perfusion, and for cryonics-associated research. In this section we will confine ourselves to the use of extracorporeal technologies for total body washout. Some research results obtained with extracorporeal technologies have been discussed in part I of this section and the use of extracorporeal technologies in cryoprotective perfusion will be discussed in the next section. While bypass technologies can potentially be used instead of closed chest compressions during the early stages of stabilization to improve cerebral perfusion and cooling, to our knowledge, emergency bypass resuscitation technologies have never been used in a cryonics case to date, despite their theoretical desirability.

Our treatment of the use of extracorporeal technologies will review the four major approaches that have been or are utilized in cryonics, starting with the least advanced approach. In short we will review: (1) open circuit gravity-assisted blood washout (2) blood washout with embalmers equipment (3) in-house fabricated air-transportable perfusion circuits and (4) utilization of professional extracorporeal perfusion equipment and contract perfusionists. We will follow this review with an exposition of specific issues associated with the utilization of extracorporeal technologies in cryonics and areas of debate that have emerged over the years. We conclude this section by identifying future potential directions for the use of extracorporeal technologies in cryonics.

### *Surgery*

All methods of blood substitution require access to the circulatory system of the patient and the placement of cannulae to flush out the blood and replace it with an organ preservation solution. While there are a variety of locations to place the perfusion cannulae, the most common practice in cryonics has been to cannulate the femoral vessels. Other options include cannulating the heart vessels (as in mainstream cardiopulmonary bypass) or cannulating the neck

vessels. In some cases these options may be pursued when the femoral vessels are too compromised to cannulate or when local edema makes femoral cannulation not feasible.

Conducting surgery for blood washout is not a basic cryonics procedure suitable for volunteers and is usually done by either professional surgeons or staff members extensively trained in the procedure. In some occasions the mortician can be persuaded to conduct surgery for blood washout but it is important to recognize that morticians are not trained to do such procedures with recovery as an endpoint and may only be able to offer limited skillset and supplies. In addition, surgery for blood washout involves making incisions and dissecting tissue; as such, this procedure should be performed in such a manner as to protect the team members from infection by wearing gloves, face masks, hair covers etc. In case of serious infectious diseases (such as HIV), extraordinary precaution need to be taken in consultation with Alcor's medical advisors.

### *Gravity-Assisted Blood Substitution*

The most basic method of washing out the patient's blood and replacing it with an organ preservation solution is to rely on gravity instead of pumps. Although it is possible in theory to use this approach in conjunction with advanced surgical skills and placement of various arterial and venous cannulae and monitoring equipment, a "gravity flush" of this kind is usually done with the assistance of a mortician or trained staff member. The absolute minimum in terms of surgical skill is the ability to place a (large bore) cannula in a major artery (such as the femoral artery) while making a large nick in the corresponding vein for venous effluent.

The pressure to flush the blood from the patient's circulatory system is created by hanging the bag(s) with the blood washout solution in the air. There are a variety of ways of doing this but one easy approach is to use a medical IV pole (which is included with some ice baths) While this method does not give staff members precise and flexible control over flow rate, the pressure in the lines and patient is set by choosing a specific height to hang the bags and the flow rate will be a function of that pressure (and the resistance presented by the cannula and vessels). One advantage of this method is that sudden,

unexpected, high pressure spikes cannot occur. A drawback of this method is that it may sometimes be challenging to achieve the pressures and/or flowrates that a specific case requires. Another drawback is temperature control. While the bags should be stored in ice water prior to deployment, as soon as the bags are hang on a pole the solution temperatures will gradually rise towards room temperature. This will decrease the cooling rate, either necessitating the use of more bags or the need for additional external cooling upon completion of the procedure.

Circuit design in a gravity flush is also basic and can but does not need to include a venous line. Other options are a pressure gauge, a sample port, and a reservoir. As a general rule, a gravity flush is expected to be conducted “open circuit,” which eliminates the option to circulate the chilled organ preservation solution to accelerate cooling to 0 degrees Celsius. While the introduction of more complex, pump-operated perfusion circuits or the use of professional perfusion equipment has largely eliminated this method of blood washout, a similar set-up has made a comeback as the default method for “field cryoprotection” (see Section 17).

The image in Figure 16-1 is reproduced from Tanya Jones’s 1997 *Stabilization and Transport manual*.

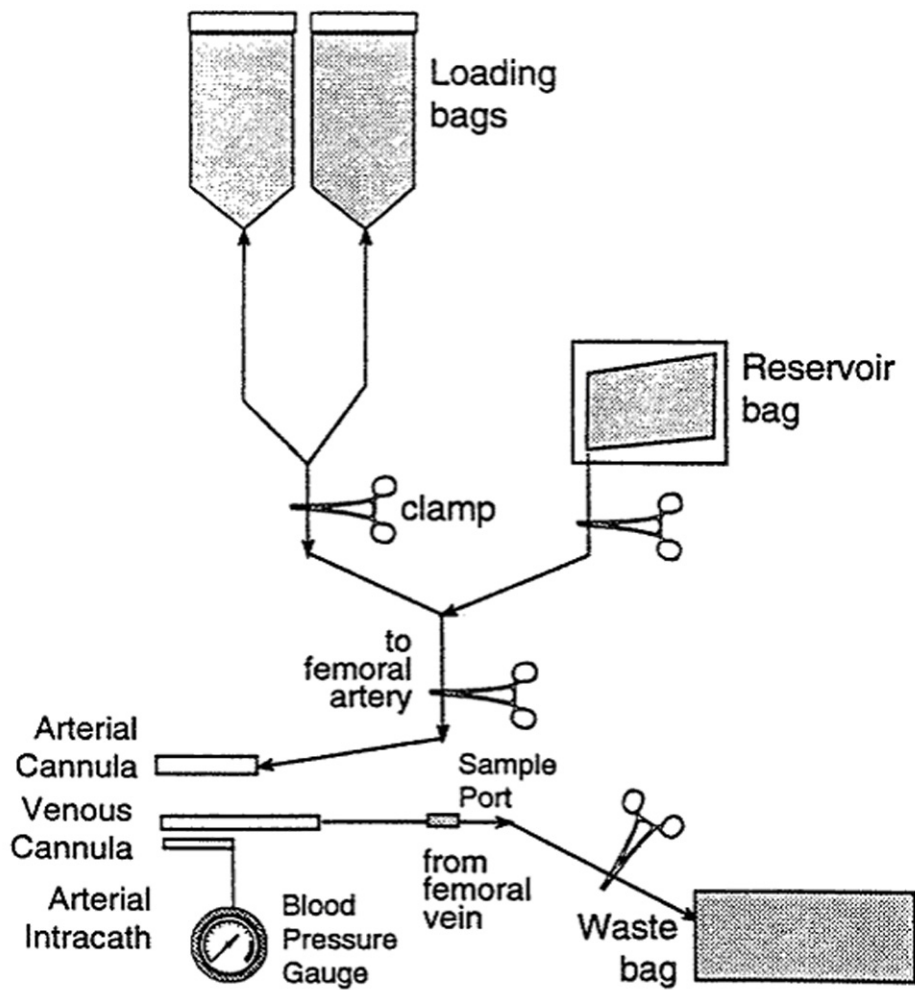

Figure 16-1. An early system of gravity-assisted blood substitution.

### *Blood Substitution with Embalmer's Equipment*

The use of embalmer's equipment can refer to either the use of embalmer's cannulae or pumps. Embalmer's cannulae are often made of steel and come in a variety of models and sizes. An example is shown in Figure 16-2. If the use of an embalmer's cannula cannot be avoided it is important to choose the right type of cannula for the right vessel and make sure to follow proper protocol to prevent air bubbles being introduced in the circuit.



*Figure 16-2. An embalmer's cannula.*

Embalmer's pumps are rather basic pumps that do not need to meet the more delicate requirements for conducting extracorporeal perfusion in humans. In particular, the finer (quantitative) control over flow rates and pressure is often lacking, both in the pumps and in the circuits used. On the positive side, the processes of embalming and blood substitution share a fundamental objective: the replacement of the patient's blood with another substance. Morticians also have extensive experience with issues such as perfusing a patient with blood clots and edema, so the presence of these phenomena in many cryonics cases should be familiar to them.

The most important reason why embalming pumps should be avoided is because of the risk of introducing particles that can block vessels. As a general rule, embalming pumps and tubing are not consistently sanitized, let alone, sterile. While the elimination of excessive bacterial activity is one aim of embalming, the complete elimination of any particles or harmful substances is not an important objective for them. Using embalmer's equipment can subject the patient to the introduction of particles that can block (micro) vessels, which can compromise subsequent cryoprotective perfusion. If an embalmer's pump is used for blood washout it is extremely important to thoroughly sanitize and clean the equipment (of fixatives!) before use. Great care should also be taken to avoid introducing air in the lines from the rotors in the device that are used to stir the embalmer's solution.

An embalming pump is shown in Figure 16-3. Note that morticians may refer to this as an embalming machine.





*Figure 16-3. Embalming pump, also known as an embalming machine.*

When utilizing the assistance of a mortician it is important to properly convey the objectives of a blood washout because many funeral directors do not realize that after blood washout and shipment of the patient to the cryonics facility the patient will be subjected to *another* surgical procedure for cryoprotective perfusion. This is one reason why it is not recommended to use vessels such as the carotid arteries and veins. This is particularly important in the case of whole body patients, who are usually cannulated through a median

sternotomy and perfused through the heart. Compromising or nicking the vessels to the brain can greatly complicate perfusion for such patients.

### *Air Transportable Perfusion Circuit*

The Alcor ATP (Air Transportable Perfusion kit) was developed in the 1990s. It constituted a key development in Alcor's remote stabilization capabilities by making its washout protocol available for all members (including international members) through the fabrication of a compact, air transportable perfusion circuit.

The ATP consists of a sterile perfusion circuit with filter and heat exchanger / oxygenator, a reservoir, and a (roller) pump that are contained in a hard shell Pelican case. As a general rule, the ATP was shipped with an additional container with 20 liters of washout solution (MHP-2) and ancillary equipment to set and run the device. An important property of the Alcor ATP is that is designed to run close circuit. This setup reduces perfusate volumes and enhances cooling rates.

As can be seen in Figure 16-4, the lid of the ATP case contains the circuit with filter and heat exchanger/oxygenator and the effluent of the patient is returned to the soft-shell reservoir bag that is also part of the lid. The organ preservation solution is drawn from a separate (chilled) bag and cooled by the in-line arterial heat exchanger and filtered before being delivered to the patient. During the washout phase the venous effluent (blood) is discarded until the effluent is consistently clear. At this stage the circuit is "closed" and the perfusate is allowed to recirculate to cool the patient to as close to 0 degrees Celsius as is practical. A diagram showing the tubing circuit of the ATP is shown in Figure 16-5.

A detailed description of the ATP, its components, and setup instructions can be found in the manual that was produced by one of the writers of this manual (Platt). A number of topics specific to the ATP that are not covered in detail in that manual are discussed here.

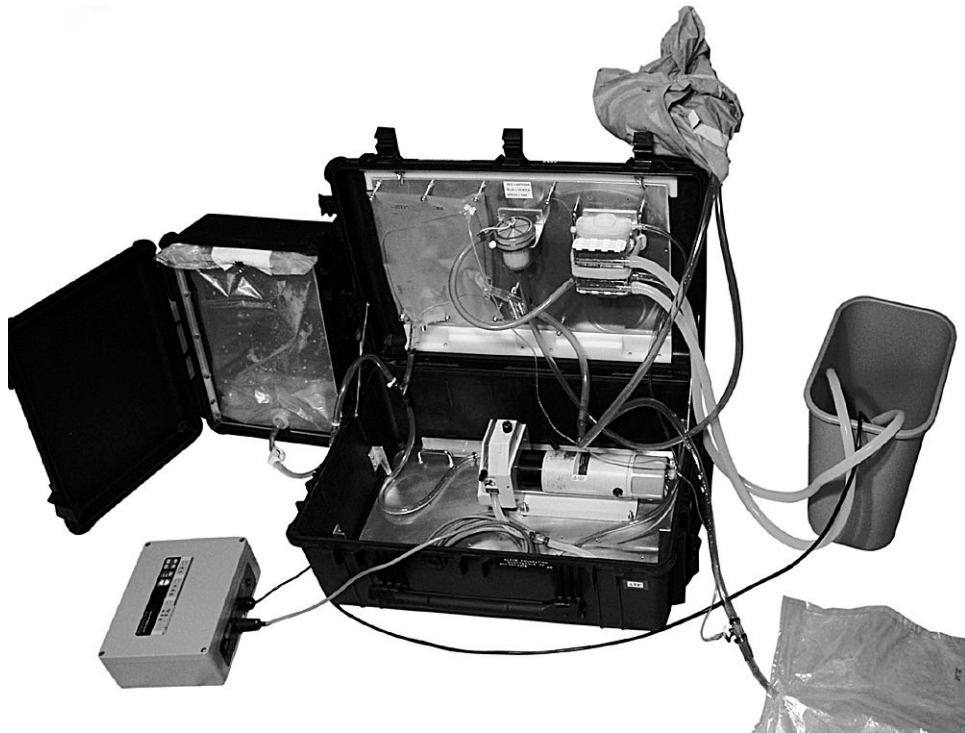

*Figure 16-4. The Air Transportable Perfusion kit developed by Alcor for remote blood washout. The fabric bundle at top-right is a sterile pack containing cannulae. The smaller case, open at left, contains perfusate. A large roller pump is visible attached to an aluminum baseplate in the main Pelican container. The box at left is the pump speed controller. A plastic waste basket was often used as an ice-water reservoir, as this did not have to be sterile. A soft reservoir bag is visible mounted in the left side of the open lid of the Pelican container. Beside it is an arterial filter, and to the right of that is a combined oxygenator and heat exchanger. A waste bladder for effluent connection can be seen at lower-right.*

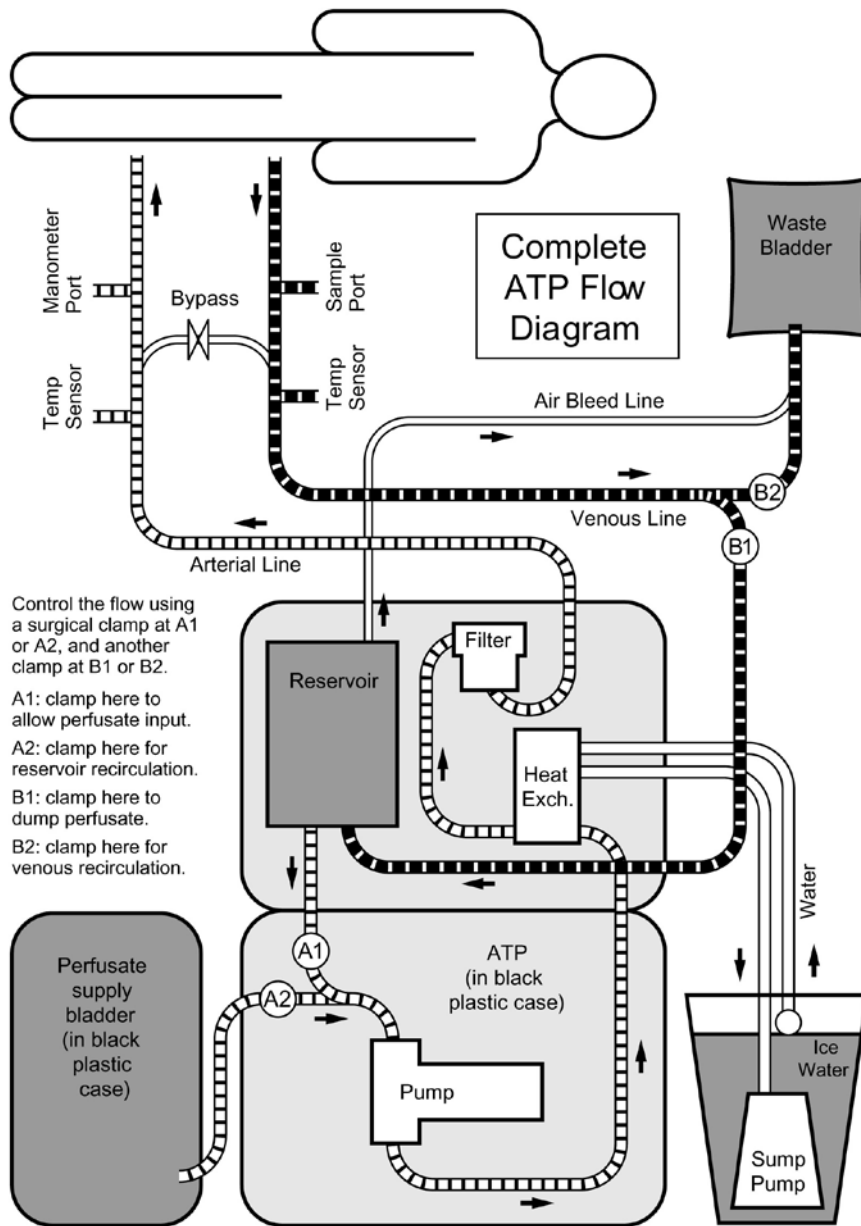

Figure 16-5. Tubing circuit of the ATP.

Most versions of the ATP included an integrated heat exchanger and oxygenator. In practice, the oxygenator has been rarely used in an Alcor case. While this would add another layer of complexity to the operation of the circuit, the omission of oxygenation during blood substitution is not

recommended. If the blood washout is initiated at relatively high temperatures (> 25 degrees Celsius) metabolic demands of the patient may still exceed endogenous energy stores. Oxygenation might even be desirable when blood washout is initiated at the recommended temperature of 20 degrees Celsius but in cases where ventilation was poor or inadequate during prior cardiopulmonary support. Adequate oxygenation during blood substitution also has the advantage that the patient starts the period of ultra-profound circulatory arrest with adequate metabolic support.

The ATP circuit has a (luer lock) sampling port (on the arterial or venous side or both) and also permits the administration of additional drugs into the reservoir. The sampling ports can be used to withdraw samples for on-site or off-site analysis (to prevent introducing air taking them from the venous side is recommended). For example, the composition of MHP-2 can be verified, or the effluent can be subjected to a series of assays to look for molecules associated with ischemia / cell injury. The option to administer medications can be used to deliver stabilization medications (injected into the reservoir) that were omitted during stabilization due to time constraints or other logistical reasons. It is also possible to administer drugs that directly assist with cardiopulmonary bypass and washout such as vasoactive drugs.

In theory, it is possible to start blood washout at near-normothermic temperatures provided rapid surgery is performed to cannulate the patient and connect him to the perfusion unit. In such a protocol it would not be advised to wash out the blood immediately as the oxygen carrying capacity of MHP-2 (an aqueous solution) would be inadequate to deliver enough oxygen to the patient and the brain in particular. In such a protocol, the patient's blood would first be circulated and oxygenated closed circuit while being cooled at the same time. As the patient reaches a temperature of ~ 20 degrees Celsius the circuit is opened to wash out the blood. After this step the washout procedure would proceed as usual. It is important to note that in such a protocol careful attention should be paid to the decreasing oxygen needs of the patient as the temperature of the patient is lowered. The team should also monitor (and adjust) other physiological measures such as pH and (cerebral) pressure. Strict conformity to the aim of keeping the patient viable by contemporary medical criteria would probably mandate this kind of procedure.

One aspect of the ATP that has not been discussed in detail is that this device, in principle, can be used, or slightly modified, for field cryoprotection with a vitrification agent, a topic that will be discussed in more detail in the section about cryoprotective perfusion.

Alcor's ATP was never meant to be the final word on a compact, portable, perfusion unit. Since the mid-2000's a new prototype perfusion unit was developed at Alcor that incorporated a hard shell reservoir, a centrifugal pump, and more advanced pressure monitoring options. To our knowledge, this unit has not been deployed in a remote Alcor cryonics case and the project was abandoned when a change in management coincided with a decision to use services from Suspended Animation for Alcor's non-local cases.

### *Professional Extracorporeal Perfusion Equipment*

While the desire to use professional perfusion equipment and medical professionals (surgeons, in particular) has shaped Alcor's objections and procedures since its incarnation, the degree to which this wish has been implemented has varied throughout the organization's history. In a sense, the development of the ATP could be perceived as a departure from using mainstream perfusion equipment while the involvement of Suspended Animation in Alcor's non-local cases returned Alcor to its older practice of using mainstream perfusion equipment and medical professionals – albeit with less control of Alcor over the conduct of these outsourced cases. At the time of the writing of this manual, practically all of Alcor's national remote stabilization cases are performed by Suspended Animation, which contracts with professional surgeons and perfusionists to perform blood substitution in the field. As much as the objectives of the procedure have remained the same, the equipment used in these cases is more advanced. For example, there has been a renewed interest in using state-of-the-art perfusion equipment such as the modular Stockert perfusion unit pictured in Figure 16-6.

While there is a broad consensus within cryonics about the objectives of blood substitution and the required equipment, a number of protocol and design issues are briefly discussed below to conclude this section.



*Figure 16-6. The Stockert perfusion system.*

### *Timing of Blood Washout*

Alcor's current human cryopreservation protocol recommends that blood washout is started either at 20 degrees Celsius or when the efficiency of

external cooling starts sharply declining (whichever comes first). The rationale for starting washout at 20 degrees Celsius is that this permits the surgeon to establish vascular access for perfusion without the risk of prolonged the ischemia that could occur if this procedure would be started closer to normal body temperature. In many cases, surgical access can only be established at a funeral home or the local cryonics facility and the patient's temperature will be approximating this target by default as a result of transport time. The protocol to simply externally cool the patient to 20 degrees Celsius has been questioned by some for a number of reasons. In the first place, there have been cases in which external cooling and cardiopulmonary support became increasingly ineffective at temperatures above 20 degrees Celsius. In the second place, some people have argued that it should be possible to conduct surgery fast enough to outpace the negative effects of normothermic circulatory arrest. For example, one could imagine a scenario in which the transport medications are administered rapidly and the duration of surgery is shorter than the maximum time these medications are perceived to effectively mitigate warm ischemia. A rejoinder to this argument is that the duration and of surgery cannot always be predicted in advance and it is more prudent to err on the side of caution and conduct surgery at lower temperatures. The issue of the timing of blood washout is highly relevant to the possibility of using mainstream emergency bypass protocols and procedures in cryonics.

### *Roller Pumps or Centrifugal Pumps*

The default option for remote blood substitution and cryoprotective perfusion in cryonics has been to use roller pumps. Some have argued in favor of a switch to centrifugal pumps. One of the major advantages of the use of centrifugal pumps is that they are unable to pump large amounts of air. Another argument is that a roller pump better mimics the pulsatile flow in normal human physiology. Arguments against centrifugal pumps include a higher learning curve, the need for inline flow rate monitoring, and their unsuitability for perfusing high viscosity solutions.



### *Hard-Shell or Soft-Shell Reservoirs*

While soft-shell venous reservoirs have been the preferred form of reservoir for Alcor's ATP, some advisors have advocated to switch to hard-shell reservoirs. Disadvantages of soft-shell reservoirs that have been put forward include: increased volume adds resistance to the venous return line, capable of only limited volumes, difficult to purge air, incompatibility with Vacuum-Assisted Venous Drainage, and inaccuracies in measuring volume. People who favor the soft-shell reservoirs have made the argument that soft-shell reservoirs collapse upon emptying (and thus limit the amount of air that can be pumped) and that their collapsibility allows for more compact perfusion circuits such as the ATP. Michael Darwin has argued that the conjunction of small volume soft-shell reservoirs and increasing tubing length and filter volume (both in contrast to mainstream perfusion) will prevent the maximum volume of air that can be accidentally pumped from being introduced to the patient.

### *The Arterial-Venous Recirculation Line*

The Alcor ATP includes an arterial-venous recirculation line. The objective of this line is to maintain cool temperatures in the circuit in case perfusion needs to be interrupted. It can also be used to purge air from the circuit in case it is caught prior to entering the patient. Without this A/V loop interruption of perfusion would warm up the perfusate and produce air bubbles. Others consider this line redundant or presenting a risk of leaving it open during perfusion, which could even produce retrograde perfusion.

### *Differential Between Perfusate and Patient Temperature*

In cryonics it is routine to expose a patient's blood to a chilled (~ 0 degrees Celsius) perfusate. Some researchers and perfusionists advocate a maximum temperature gradient of 10 degrees Celsius to avoid the microbubbles that are associated with larger gradients. Whether these microbubbles produce clinically relevant pathologies in patients has not been resolved in the literature and there have been no distinct events in cryonics that prompted to revisit current protocols.

### *Assisted Venous Drainage*

Poor venous return has been observed in some cryonics cases. One suggestion to deal with such cases is to add some type of assisted venous drainage to increase venous return. There are a variety of ways to accomplish such an objective. The most basic approach is gravity-assisted drainage in which the venous reservoir is placed a couple of feet lower than the cannula. One advantage of the portable ice baths with tall legs (as opposed to those that are constructed to be close to the floor) is that they can facilitate such gravity-assisted drainage. In fact, this kind of gravity-assisted venous drainage has been the default procedure in both blood washout and cryoprotective perfusion cases at Alcor. There are two other, “active,” forms of assisted venous drainage: Vacuum-Assisted Venous Drainage (VAVD) which is achieved by applying suction to a closed hard-shelled venous reservoir and Kinetic-Assisted Venous Return (KA VD) which is achieved by incorporating a second pump into the perfusion circuit between the patient and the reservoir. Although these approaches have been used with success in mainstream perfusion their use has generally been discouraged in cryonics because of their greater complexity and risk (such as collapsing a vein or introducing air). In case this approach is used it is recommended that the negative pressure applied to the venous line should not be allowed to exceed approximately 40mm Hg.

The topic of assisted venous drainage is also relevant to cryoprotective perfusion, and whole body cryopreservation in particular. Unlike isolated head perfusion, in which the whole stump of the patient’s head is available for drainage, good venous return in whole body cases can be challenging and additional strategies may need to be employed to achieve adequate venous drainage.

### **Notes**

1. Leaf Jerry D, Darwin Michael G, and Hixon Hugh. “A mannitol-based perfusate for reversible 5-hour asanguineous ultraprofound hypothermia in

canines.” Cryovita Laboratories, Inc. and Alcor Life Extension Foundation. Found at <https://www.alcor.org/Library/html/tbwcanine.html>

2. Hossmann KA, Hossmann V. Coagulopathy following experimental cerebral ischemia. *Stroke*. 1977 Mar-Apr;8(2):249-54.

3. Böttiger BW, Motsch J, Böhrer H, Böker T, Aulmann M, Nawroth PP, Martin E. “Activation of blood coagulation after cardiac arrest is not balanced adequately by activation of endogenous fibrinolysis.” *Circulation*. 1995 Nov 1;92(9):2572-8.

4. Fischer EG, Ames III A. “Studies on mechanisms of impairment of cerebral circulation following ischemia: effect of hemodilution and perfusion pressure.” *Stroke*. 1972 Sep-Oct;3(5):538-42.

5. Tisherman S, Chabal C, Safar P, Stezoski W. “Resuscitation of dogs from cold-water submersion using cardiopulmonary bypass.” *Ann Emerg Med*. 1985 May;14(5):389-96.

6. Safar P, Stezoski W, Nemoto EM. “Amelioration of brain damage after 12 minutes’ cardiac arrest in dogs.” *Arch Neurol*. 1976 Feb;33(2):91-5.

7. Dr. Rubens Costa, as relayed by Dr. Claudia Teles on the Critical Care Medicine Mailing List on May 30, 2006

8. Gordon, Shapiro, Berson, *Forensic Medicine: Guide to Principles*, 3rd edition, (1988), Churchill Livingstone, Edinburgh.

9. P. Colm Malone and Paul S. Agutter, “The Aetiology of Deep Venous Thrombosis: A Critical, Historical and Epistemological Survey” (2008)

10. Fuller BJ, Lee CY. “Hypothermic perfusion preservation: the future of organ preservation revisited?” *Cryobiology*. 2007 Apr;54(2):129-45.

11. White-RJ, Albin-MS, Verdura-J. “Isolation of the monkey brain: in vitro preparation and maintenance.” *Science* 141:1060 (1963).

12. White-RJ, Albin-MS, Verdura-J. “Preservation of viability in the isolated monkey brain utilizing a mechanical extracorporeal circulation.” *Nature*. 202:1082-1083 (1964).

13. White-RJ, Albin-MS, Verdura-J, Locke-GE. “Prolonged whole brain refrigeration with electrical and metabolic recovery.” *Nature* 209:1320 (1966).

14. White RJ. “Modifications in primate cerebral circulation and electrical activity with profound hypothermia.” *Cryobiology*. 1972 Oct;9(5):383-92.

15. Mukherji B, Sloviter H.A. "Metabolism of an isolated brain perfused with perfluoro blood substitute." *Journal of Biosciences*. 1987 Mar; 11(1-4): 23-33
16. Haneda K, Thomas R, Sands MP, Breazeale DG, Dillard DH. "Whole body protection during three hours of total circulatory arrest: an experimental study." *Cryobiology*. 1986 Dec;23(6):483-94
17. Leaf Jerry D, Darwin Michael G, and Hixon Hugh. "A mannitol-based perfusate for reversible 5-hour asanguineous ultraprofound hypothermia in canines." Cryovita Laboratories, Inc. and Alcor Life Extension Foundation. Found at <https://www.alcor.org/Library/html/tbwcanine.html>
18. Harris, SB. "Initial Cooling in Cryonics." Unpublished manuscript.
19. Unpublished research at Critical Care Research
20. Nakashima K, Todd MM. "Effects of hypothermia on the rate of excitatory amino acid release after ischemic depolarization." *Stroke*. 1996 May;27(5):913-8
21. Leaf Jerry D, Darwin Michael G, and Hixon Hugh. "A mannitol-based perfusate for reversible 5-hour asanguineous ultraprofound hypothermia in canines." Cryovita Laboratories, Inc. and Alcor Life Extension Foundation. Found at <https://www.alcor.org/Library/html/tbwcanine.html>
22. Sekaran P, Ehrlich MP, Hagl C, Leavitt ML, Jacobs R, McCullough JN, Bennett-Guerrero E. "A comparison of complete blood replacement with varying hematocrit levels on neurological recovery in a porcine model of profound hypothermic (<5 degrees C) circulatory arrest." *Anesth Analg*. 2001 Feb;92(2):329-34
23. Shin'oka T, Shum-Tim D, Jonas RA, Lidov HG, Laussen PC, Miura T, du Plessis A. "Higher hematocrit improves cerebral outcome after deep hypothermic circulatory arrest." *J Thorac Cardiovasc Surg*. 1996.
24. Patent Number: 5,082,831
25. Leaf Jerry D, Darwin Michael G, and Hixon Hugh. "A mannitol-based perfusate for reversible 5-hour asanguineous ultraprofound hypothermia in canines." Cryovita Laboratories, Inc. and Alcor Life Extension Foundation. Found at <https://www.alcor.org/Library/html/tbwcanine.html>
26. *Cryonics*, Volume 8(12), December 1987.
27. Quoted on the old Viaspan website.

28. Ames A 3rd, Wright RL, Kowada M, Thurston JM, Majno G. "Cerebral ischemia. II. The no-reflow phenomenon." *Am J Pathol.* 1968 Feb;52(2):437-53.
29. Steen PA, Michenfelder JD, Milde JH. "Incomplete versus complete cerebral ischemia: improved outcome with a minimal blood flow." *Annals of Neurology.* 1979 Nov;6(5):389-98.
30. Rea TD, Cook AJ, Hallstrom A. "CPR during ischemia and reperfusion: a model for survival benefits." *Resuscitation.* 2008 Apr;77(1):6-9.
31. Marks JD, Pan CY, Bushell T, Cromie W, Lee RC. "Amphiphilic, tri-block copolymers provide potent membrane-targeted neuroprotection." *FASEB J.* 2001 Apr;15(6):1107-9
32. Yuri Pichugin. *Cryonics Institute Research Report* for 2005, 2006 and 2007.
33. Michael Darwin, Jerry Leaf, Hugh L. Hixon. "The Effects of Cryopreservation on the Cat." Research reported on Cryonet, December 1992.

## 17. Patient Transport

Figure 17-1 shows some of the options for transporting a patient to a cryonics facility from the location where death has been pronounced. We are assuming that blood washout and, optionally, neuroseparation and neurocryoprotection will be done either in a mortuary or a suitably equipped ground vehicle. Other possibilities exist but are not shown, as they are less commonly used. The chart also omits cases that originate overseas.

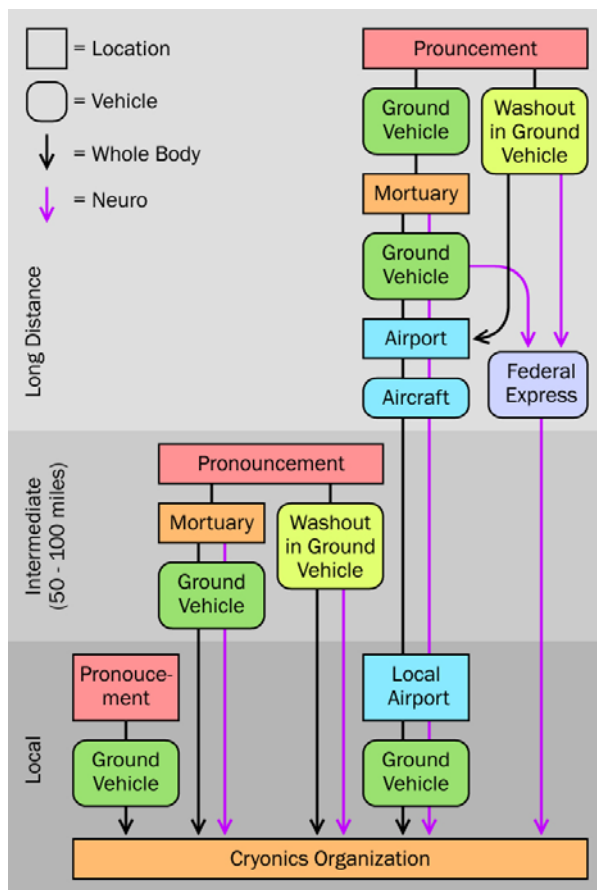

Figure 17-1. The most commonly used transport options for patients originating inside the United States. Note that blood washout may also be done at the Mortuary.

For local cases, the ground vehicle is usually owned by a cryonics organization. During a remote standby, a vehicle that has been equipped for cryonics procedures may not be available if the distance is too great or there is insufficient time for deployment. Team members may rent a van locally, or may depend on a collection service associated with a mortuary.

Intermediate-distance cases are arbitrarily defined here as 50 to 500 miles, such as those that originate in Southern California (where a large number of cryonicists are located) and terminate at the Alcor facility in Scottsdale, Arizona. Chartered aircraft have been used in such cases, but rarely.

Federal Express is an option reserved for neuro cases shipped on dry ice, after neuroseparation has been performed in a remote location.

Air transport may be by scheduled airline or chartered jet, depending on the funding that is available for the case and the location of the patient.

Sometimes more than one option will be available, and choosing between them may be difficult, always bearing in mind that rapid transport and rapid cooling are the primary considerations. Suppose that a patient is pronounced at a location four or five hours from the cryonics facility via ground vehicle. Can the cryonics organization deploy a vehicle to the area before death is pronounced? If so, can blood washout be performed in the vehicle by a suitably qualified person, or should the patient be moved to a mortuary, even though this will add some extra time? Suppose the patient prefers whole-body preservation but has signed an option for neuro conversion if this will optimize the case. Should neuroseparation be done at a mortuary, followed by transport on dry ice, or should whole-body washout be done, followed by transport on water ice? Such decisions have to be made on a case-by-case basis.

## **Local Ground Transport**

We may hope that a local case will originate in a home, hospital, or hospice where the cryonics organization has secured cooperation and has been able to station an ice bath and supplies near the patient. After pronouncement, the patient is placed in the ice bath, a pump circulates ice-cold water over the head

and body, CPS begins, medications are administered, and these activities should continue with minimal interruptions while the ice bath is wheeled to the transport vehicle and driven to the cryonics facility.

Local transport will typically take less than an hour, but preparations for cryoprotection at the cryonics organization may take longer. To minimize the risk of the facility being unprepared when the patient arrives, active communication is essential. Staff at the facility should be given frequent updates about the condition of the patient prior to legal death, and must be informed immediately when death has been pronounced and the transport has begun.

A wheeled ice bath that has legs to raise it above floor level is useful for ground transport in a vehicle dedicated for cryonics cases. The vehicle must have an easily operated clamp to restrain the ice bath during transport, as the weight of the ice bath, with its patient and a full load of ice and water, will be hazardous to personnel if it can roll around.

A discussion of appropriate vehicles that can be customized for transport of cryonics patients will be found in the addendum to this section, illustrated by three examples.

## **Ground Transport to Mortuary**

The term “mortuary” in this subject heading includes any environment where surgery and blood washout may be possible, in a location that is remote from the cryonics organization.

When team members fly to a remote standby, if a vehicle adapted for cryonics procedures is not available, renting a van near the airport is the next-best option. A passenger van or minivan will not be appropriate, as they have seats and windows. A cargo van is preferred, although rental offices for this type of vehicle may be at a different location from automobile rentals. Making a phone call to check availability of cargo vans at the actual renting office is a worthwhile precaution. Google search results, and staff at 800-number call centers, are not necessarily reliable.

Ideally, the decision to rent a van should be made before deployment. Staff at the cryonics facility can make the reservation and verify the van’s



location while team members are in flight. If there are at least three team members, they can divide the tasks among them when they reach the destination airport. Person A stays at the airport to wait for baggage to come off the carousel; Person B takes a taxi to the patient's location to make personal contact with medical staff and any friends or relatives; Person C takes a taxi to rent the van, then drives it back to the airport to collect Person A and all of the equipment. If the patient's death seems imminent, equipment can be divided between the patient's location and the mortuary. Another scenario is when an active local cryonics group draws upon its local resources and secures a suitable van for the arriving team.

When choosing a van, bear in mind that while high-roofed vehicles are easier to work in, they are usually too tall for multistory parking garages. Also consider that while a longer vehicle is more convenient on the inside, it is more difficult to park on the street, and may require more driving skill.

Because a standby is always unpredictable, renting a van for a longer period than seems necessary is a sensible precaution. A vehicle can usually be returned early for a refund, but extending a short rental may not be possible.

At an Alcor standby in Texas, a van was rented for four weeks (the maximum allowed) and was parked in a multistory garage adjacent to the hospital where the patient was located. Basic standby equipment (excluding medications and valuable items) was left in the vehicle. When the patient made an unexpected partial recovery, team members abandoned the standby and returned to Arizona but left the vehicle in its parking spot. Three weeks later, when nurses called to warn Alcor that the patient's condition was deteriorating, the team returned and resumed the standby. The cost of the long van rental, plus the parking charges, was comparable to the cost of flying equipment to and from Arizona. The decision to leave some equipment in Texas was made bearing in mind that Alcor had more than one full set of standby-transport equipment at that time.

## **Equipping a Rented Vehicle**

Interior lighting is the most important consideration if any procedures will be attempted in a windowless rented van. The default lighting in a van will be

meager at best. Large LED flashlights can be duct-taped into position around the load area. Their battery life should be sufficient for even a prolonged standby, but extra batteries are always a good precaution.

A DC-AC inverter that plugs into a cigarette-lighter socket is useful. If one is not included in the standby kit, it can be bought at any local auto-parts store or Home Depot. A splitter for the lighter socket is useful, so that two or three devices can share it.

The rear doors on a typical van are not tall enough to allow an ice bath on legs to be loaded, and lifting an ice bath on legs into the vehicle is hazardous, especially while CPS is being administered by a chest-compression device. Any ice bath used in conjunction with a rented vehicle should have detachable legs, or no legs at all.

If a team doing a remote standby prefers not to rent a vehicle, a mortuary will either have its own vehicle to collect patients who have been pronounced or will retain an independent collection service. These options for transport are not ideal, as they may not allow continuation of stabilization procedures during transport. Also, collection services cannot be expected to share any sense of urgency.

## **Preparation for Air Transport**

It is not commonly realized that scheduled airlines frequently transport people who are legally dead. After the body has been embalmed, a mortician places it in a utilitarian container known as a Ziegler box, fabricated from thin galvanized steel. The box is strapped to a plywood shipping tray, and a corrugated cardboard cover is added for cosmetic purposes. To be discreet, morticians and airlines often use the name Jim Wilson to mean a deceased person, and the shipping tray is often referred to as a Jim Wilson tray.

In a cryonics case, as early as possible (preferably before deployment begins) the cryonics organization, cryonics standby/stabilization contractor, or local group should establish the precise location of a cooperating mortuary relative to the current location of the patient and location of the nearest airport, bearing in mind typical highway conditions, especially during rush-hour

periods. The organization must establish which airlines are used by the mortician, and must compile a list of flight departure times.

A mortician will have a pre-existing arrangement to ship cargo via at least one airline, will know where the cargo section of the airport is located, and will know all the regulatory requirements that must be fulfilled before the airline will accept the cargo. A mortician will also know what legal requirements must be satisfied to move a deceased person out-of-state (see the section below titled Legal Considerations). Attempting to transport a cryonics patient on a scheduled airline without using the services of a mortician is not recommended.

When airline schedules are compared, any route involving a change of aircraft is undesirable, as it greatly increases the risk of delays. Note that a “direct” flight may entail one or more stops along the route, but the same aircraft will be used from start to finish.

The transport team should be fully informed about flights before they reach the mortuary. In a worst-case scenario, a team member can obtain flight information while blood washout is in progress. It is not acceptable for the team to start thinking about flight options after washout is complete. In an ideal situation, local Alcor groups maintain and update this kind of information for potential cases.

Because the cooperation of a mortician is so important, a cryonics organization or standby team should avoid hard bargaining over a mortician’s fee, and should consider offering a bonus for handling a case ahead of other obligations. This should be effective to obtain rapid response. Most mortuaries are not high-profit businesses, and they appreciate receiving more money than they expected.

## **Preparation for Whole-Body Transport in Water Ice**

While the patient is on bypass for blood washout at a mortuary, the team can assemble the necessary items for air shipment on water ice.

A Ziegler box is usually provided by the mortuary. While most mortuaries keep at least one Ziegler box in stock, an unusually large patient may require an oversize box. If the cryonics organization is aware that a

patient is significantly larger than average, it should notify the mortuary in advance. The mortuary may have an oversize box in stock, or may have to order one. The box must be large enough to allow room for ice to be packed around the patient.

In an unlikely situation where a mortuary does not have a Ziegler box, a bare-minimum casket can be used, but will add substantially to the cost.

The team will need 40 kg of water ice (more, for a large patient) and sufficient 1-gallon ziploc bags to contain it. Ice cannot be placed loose around the patient. A Ziegler box is not watertight, and any leakage of fluid can be grounds for an airline to refuse a shipment, even if the fluid is only water. Ice must be bagged securely. Double bagging in ZipLoc bags is preferred if time permits. The minimum amount of ice will depend on the weight of the patient, as discussed below.

It is important that water ice used to ship cryonics patients be visibly wet. Wet ice is ice that has started melting at a temperature of 0 degrees Celsius. This is the desired shipment temperature. Ice that was stored in a freezer will initially be at the subzero temperature of the freezer. Ice that is not visibly wet or appears covered in frost is still at subzero temperature. If ice at subzero temperature is placed in contact with a cryonics patient, it may cause tissues of the cryonics patient to freeze. Subzero temperature ice can be warmed by either waiting or pouring small quantities of water on the ice until it stays visibly wet and/or all frost on the ice or ice bags disappears.

Sealed freezer packs may be used instead of water ice. To avoid freezing the patient, it is important that the packs have a melting temperature of 0 degrees Celsius, and that the packs be warmed enough to melt any white frost covering the packs. Freezer packs with white frost on the surface can freeze cryonics patients. A disadvantage of freezer packs compared to bagged ice is that it may not be possible to tell how much of the interior material of freezer packs has melted. For this reason, freezer packs should ideally be obtained at a temperature such that they still have frost on them and the frost observed to melt shortly before packing the patient.

If because of any emergency situation a patient must ever be shipped with less ice than covers them completely, or under circumstances in which

endurance of the ice during shipping may be in doubt, a priority should be placed on covering the head of the patient with ice.

For maximum security, the patient should be double-bagged to minimize the risk of leakage of body fluids. A 3-mil body bag of the type used by mortuaries should be enclosed in a 20-mil body bag of the type used in forensic work. Although the mortuary is likely to have 3-mil bags in stock, it is unlikely to have the heavier type of bag. This should be included in the remote standby kit.

Thermal insulation of the Ziegler box is essential, especially in summer weather. Hugh Hixon at Alcor is a believer in using fiberglass insulation, which is always available locally from big-box hardware stores. However, it can cause a skin rash and may require eye protection and a dust mask. Some mortuaries may be unhappy about a team cutting fiberglass insulation on their premises.

We recommend polyisocyanurate foam board as an alternative, as it is very easy to work with. It should be at least half-an-inch thick, and foil-coated on one side, with an R value of at least 3.0. Rmax is a brand that we have tested.

In areas of the country where very high or very low temperatures are rare, this foam board may be unavailable. Therefore, we recommend including precut sections of foam board in a standby kit. Suspended Animation developed sections that were taped together so that they could be zig-zag folded. Figure 17-2 shows the unfolding and application of these sections around a Ziegler box. At top left, the folded sections are shown. At top right, the sections that go under the box have been unfolded. At bottom left, the box has been placed on the unfolded foam board. At bottom right, the remaining sections are taped around it.



Figure 17-2. Unfolding and taping pre-cut foam board around a Ziegler box.

Duct tape is necessary to attach the foam board. It should be a standard item in the remote standby kit.

If a standby team will need to buy foam board locally, phone calls should be made before deployment to find a source that stocks it. Thermal insulation is an important issue, as it is crucial for transport on water ice.

## **Minimum Weight of Water Ice**

At Suspension Animation, tests were performed in 2005 to determine the minimum weight of ice for transporting a hypothetical patient. Inside a Ziegler box, a styrofoam dummy was wrapped in one 3-mil lightweight body bag plus one 20-mil heavyweight body bag, and was then packed in 45 kilos of bagged water ice (approximately 100 lbs). A thermocouple measured temperature at the surface of the dummy's "head."

The experiment was done three times. In the first trial, no insulation was used around the Ziegler box. In the second trial, half-inch Rmax board with an R value of 3.2 was used. In the third trial, generic unbranded bare 2-inch large-cell styrofoam board was used.

Insulation in the second and third trials was cut roughly to size and taped around the exterior of the Ziegler box after it was screwed shut. The board was applied without much attention to detail, simulating the haste of a standby team working under time pressure.

In all three trials, the Ziegler box was lowered into a plywood shell containing two thermostatically controlled hair dryers that maintained a temperature ranging between 24 and 25.5 degrees. Thus, the environment of the Ziegler box was kept at a nearly constant temperature. Each experiment ran until the internal thermocouple probe showed the temperature of the "patient" rising above 8 degrees Celsius. Data is shown in the curves in Figure 17-3.

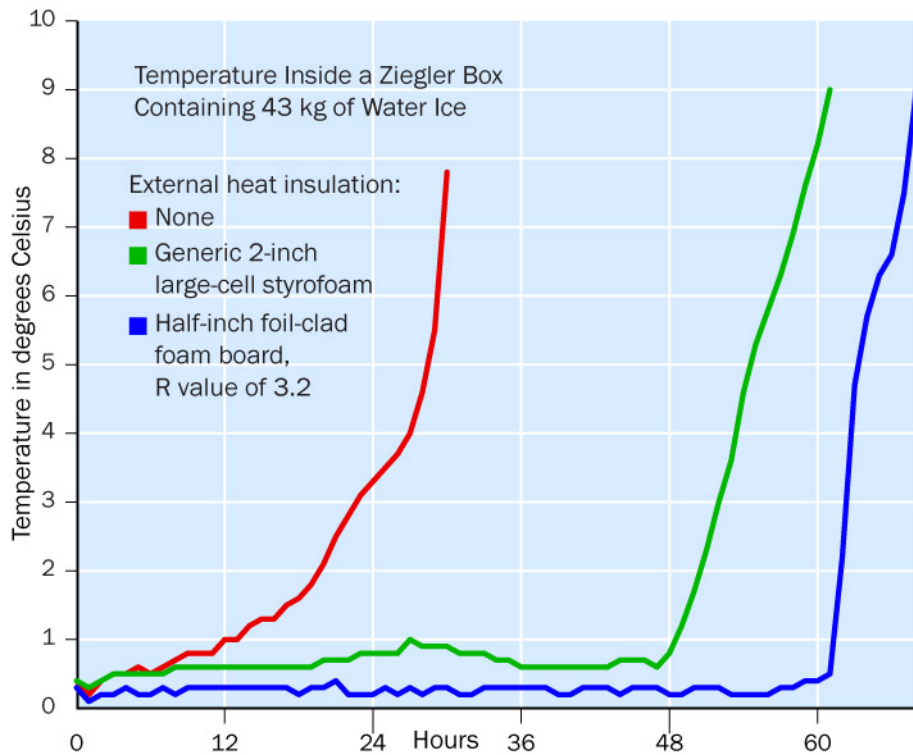

Figure 17-3. Time taken for ice to melt, using three options for insulation.

Because the styrofoam dummy patient had almost zero thermal mass, this experiment demonstrated the time taken for ice to melt if a patient contributes no heat to the process. In reality, a patient will begin the procedure at a temperature above the melting point of ice, and will contribute heat as a function of body weight and body temperature.

We may assume that the initial body temperature will range from around 10 degrees Celsius or lower (if blood washout has been done), up to 20 degrees Celsius (if there was CPS without blood washout), and even up to 37 degrees Celsius (if there was no CPS and prompt transport after legal death). The specific heat of a human body is comparable to that of water (i.e. 1 calorie per gram). Bearing in mind that the latent heat of fusion of water is 80 calories per gram, a patient weighing 80 kilograms, with a temperature of 10 degrees Celsius, will have sufficient heat capacity to melt 10 kg of ice, excluding other factors. The same patient with a temperature of 15 degrees will melt 15 kg of ice, and so on.



A good rule-of-thumb to remember is that a patient will melt a minimum of half their own weight of water ice while cooling from normal body temperature to 0 degrees Celsius. This is especially important to remember if a warm patient that didn't receive initial stabilization and cooling is packaged for transport while still warm. It's tempting to think that twice the amount of ice packed with a patient for transport will last twice as long. That's only true for whatever extra ice is left over after all the ice that melts due to body heat of the patient while the patient is still cooling toward 0 degrees Celsius.

Bearing these factors in mind, a nomogram to assist in determining the weight of ice that will be melted by the patient's body heat is shown in Figure 17-4. Place a straight edge between the weight of the patient and the temperature of the patient (in Celsius degrees), and you will find the approximate weight of ice. This nomogram works for either pounds or kilograms as long as the same weight unit is used for both the patient weight and ice weight.

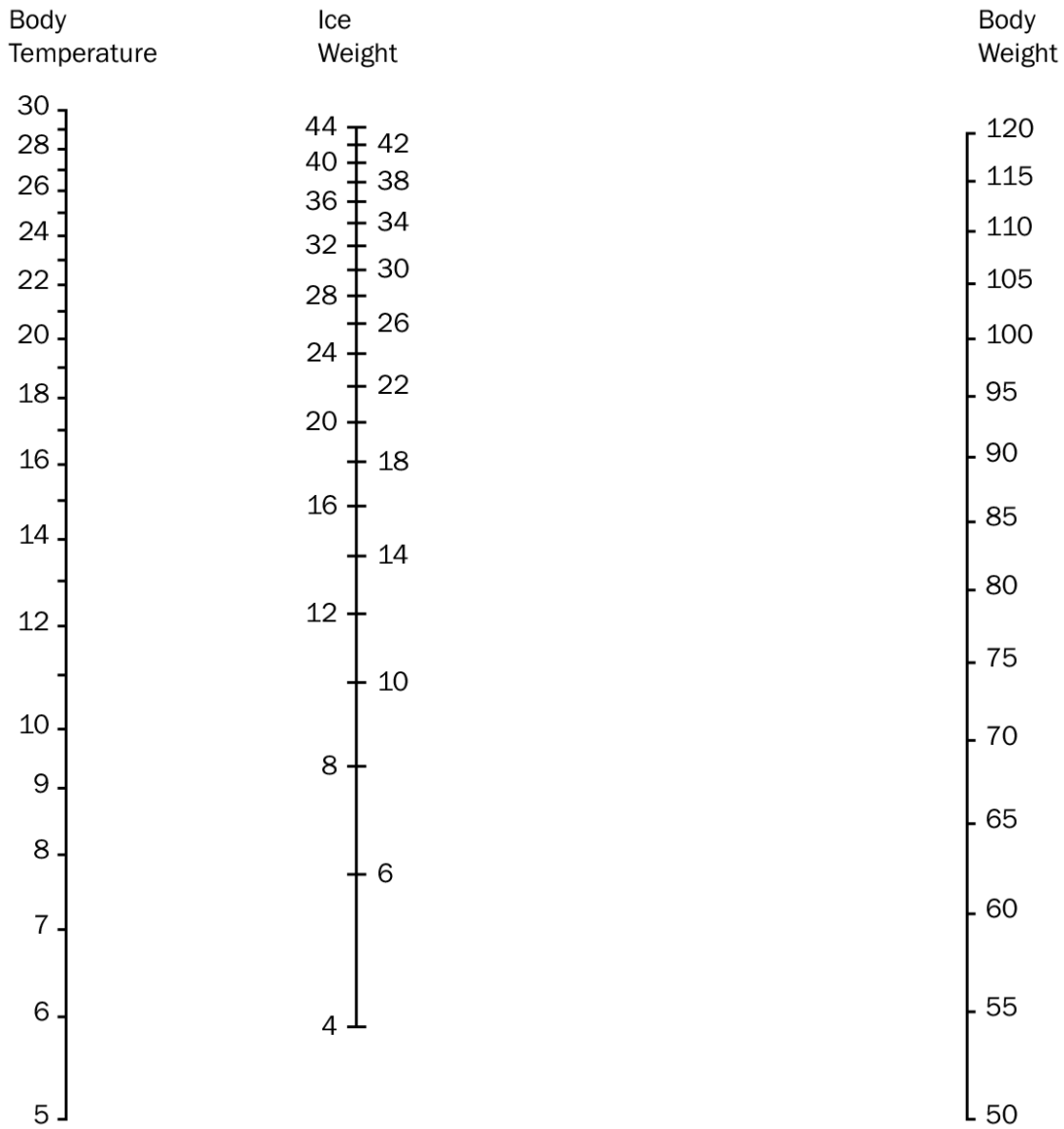

Figure 17-4. Nomogram to determine how much ice will be melted by body heat from a patient at the body temperature in degrees Celsius on the left side who has the body weight on the right side. Lay a ruler between the left and right scales to find the amount of ice that will melt. This nomogram works for either pounds or kilograms as long as the same weight unit is used for both the patient weight and ice weight. For shipping in a box with R3 insulation, add 50 pounds or 20 kilograms of extra ice to the ice weight to account for heat incursion from outside the box during transport.

Now you must factor in the penetration of heat from outside the box. For a hypothetical 24-hour transport, a minimum of 50 pounds or 20 kg of extra ice should be added to the value from the nomogram.

These numbers for extra ice to add are only valid if foam-board insulation of R3 value or higher is used around the Ziegler box. As Figure 17-3 indicates, the type of insulation is crucial. Without insulation, more ice will melt per hour of transport time, and there will be greater risk of moisture condensation forming and leaking outside the transport container, especially in humid climates.

## **What Can Go Wrong**

Any list of problems relating to transport is inevitably incomplete, but here are some examples derived from actual cases.

- The team doesn't buy enough ice.
- The team doesn't have enough bags for the ice.
- The team doesn't buy enough insulation, or can't find it, or can only obtain it from a location that requires a long drive from the mortuary, causing a delay.
- The patient may be too large to fit into the available Ziegler box with sufficient ice.
- The mortician may not have a pre-existing arrangement with an airline that has the best available flight.
- The team may encounter heavy traffic or other factors causing them to miss the flight.
- The flight may be delayed.
- Paperwork that the airline requires may be incomplete.

- If transport requires a connection between two flights, the patient may miss the connection.
- Delays in offloading the patient at the receiving end may occur.

To guard against unexpected eventualities, the patient should be packed in sufficient ice for a trip lasting at least twice as long as the expected duration. In case a patient is transported on dry ice, an even more stricter protocol need to be adhered to.

## **Transport by Chartered Aircraft**

If the patient is sufficiently well funded, a chartered aircraft is an attractive option. However, the charter company must be notified that a Ziegler box will be loaded into the aircraft. Some Lear jets have a wide door suitable for medical teams to load and unload stretchers, and should be capable of accommodating a Ziegler box. An aircraft with a standard-sized (narrow) door will not be suitable.

The team should maintain contact with the charter company while the patient is being moved to the mortuary, and while perfusion is in progress.

A chartered aircraft offers three major advantages. First, the aircraft will wait for the patient to reach the airport, and will then take off immediately. Second, minimal paperwork will be required, as freight on the chartered aircraft does not have to go through the certification process required for scheduled airlines by the TSA. Third, if the chartered aircraft lands at a private FBO instead of a public airport terminal, a cryonics transport vehicle may be allowed to drive onto the tarmac for direct transfer of the patient from the plane. The current headquarters of the Alcor Life Extension Foundation are situated beside an airport where this is possible.

Note that although chartered aircraft may seem a more reliable option, in at least one cryonics case the aircraft turned out to be unavailable when needed. The standby team should have contact information for more than one charter service.

## **Neuro Transport in Dry Ice**

Because dry ice is less reliably and widely available than water ice, phone calls should be made to sources of supply as early as possible in the standby operation—preferably before the team is deployed. Better even is for Alcor, SST (standby/stabilization/transport) contractors, or a local group to maintain a list of locations and their opening hours. In one case, dry ice was completely out of stock in almost all locations because the case occurred at the beginning of November, and a lot of people had bought dry ice to create clouds of vapor in conjunction with Halloween.

For cases originating overseas, dry ice may be less easily available than in the United States.

Alcor's neuro shipper is shown in Figure 17-5. It consists of a styrofoam box with a layer of silvered mylar bubble-wrap around it, packed in a Pelican transport case in which the hygroscopic element in the pressure-relief valve has been removed, leaving a simple air vent. The case allows room for a data logger that will record temperatures during the transport.



*Figure 17-5. Dry-ice shipping container for an isolated cephalon, at Alcor Foundation.*

After placing thermocouples in the cephalon, it is lowered into the styrofoam box, and as many pieces as possible of dry ice are stacked around it. The box is closed and moved to a location where cooling progress can be monitored. When core temperature of the cephalon is close to -79 degrees Celsius the dry ice is replenished again. After the dry ice is replenished the dry ice shipper with cephalon needs to be tested for at least the duration of

transport before authorizing transport. After this protocol is followed, it is transported to the Alcor facility by airline or Federal Express. Generally speaking, Federal Express is considered more reliable than an airline. The contents of the Pelican case are declared as cryopreserved tissue samples.

## **Whole-Body Transport in Dry Ice**

Because of the length of time that may be involved in whole-body shipment from overseas, dry ice is preferable to water ice in all cases.

In Figure 17-6, a Ziegler box is visible inside an insulated whole-body dry-ice transport container built by Alan Sinclair in the UK. This container has been used for one whole-body patient originating in a country outside of the United States. Almost all the dry ice had vaporized by the time the patient reached Alcor, leading to the conclusion that an ideal whole-body shipping container does not yet exist. To avoid such scenarios in the future, dry ice transport of whole body patients needs to follow the same rigorous protocol as for neuro patients. After cooling the patient to dry ice temperature, the dry ice is replenished and the shipper is tested for its ability to maintain dry ice temperature for at least the duration of the trip (but preferably much longer) before any shipping can commence. Under no circumstances should a patient be shipping on dry ice before the patient has reached dry ice temperature and the box is validated for at least the expected duration of the trip (using conservative assumptions).



*Figure 17-6. A whole-body dry-ice shipping container designed and built by Alan Sinclair in the UK. A Ziegler box is visible inside it. This particular photograph shows gaps in the foam insulation surrounding the Ziegler case. It should be noted that this is highly undesirable for insulating efficiency because even small air gaps between insulating panels will support heat transport by passive convection. This can be ameliorated by interleaving small gaps between two or more panel layers so that there are no gaps directly connecting the shipping container interior and exterior.*

In overseas cases, a mortician with wide experience of international shipment is essential.

## **Intermediate-Distance Ground Transport on Water Ice**

When transport is done on water ice, minimizing the duration is essential. The patient should be exposed to cold ischemia for as brief a period as possible.

Suppose a patient has received whole-body blood washout at a mortuary 500 miles from a cryonics organization. Is ground or air transport the



preferred option? Bear in mind, a rented vehicle can be used for ground transport if the organization's own vehicle has not been deployed.

What if the distance is 1,000 miles? What is the distance threshold beyond which air shipment is always the preferred option, and what is the threshold below which ground transport should be used?

These questions entail balancing the advantage of rapid air transport against the risks associated with losing control of the patient. After a Ziegler box has been received by airline personnel, the situation is almost totally outside the control of the cryonics organization. By comparison, if the standby team drives the patient back to the facility, there is a much higher probability of arriving on time, and the team can provide frequent updates while they are on the road.

Suppose the patient is in a mortuary 500 miles from the cryonics organization. The standby team has determined that a flight will leave 2 hours after blood washout is complete, and the airport is only a few miles away. Suppose the flight time is 1.5 hours, and the patient will be unloaded and ready for pickup 1 hour after the aircraft lands. Suppose the arrival airport is 0.5 hours from the cryonics facility, and no traffic delays are expected. Under these circumstances, the total transport time, from when the patient leaves the mortuary to when the patient arrives at the facility, will be 5 hours. This scenario does not include any unexpected delays. In a less-favorable scenario, the transport time could be 10 hours.

By comparison, if transport is done by ground from the mortuary to the cryonics organization at an average speed of 60 miles per hour, the total transport time will be a little over 8 hours.

We tend to feel that for distances up to 500 miles, ground transport is the better option, assuming a vehicle is available. Above 500 miles, it can be a difficult judgment call.

This is a major reason why neuro-cryoprotection followed by dry-ice shipment can seem desirable. When the patient's temperature has been lowered to -79 degrees Celsius, transport time is much less critical.

## **Legal Issues**

So long as a human body does not cross a state line after legal death, legal issues are minor. If the body is transported from one state to another, a death certificate and/or a transit permit may be required.

Each state has its own laws regarding the removal of human remains, and each county may have additional regulations. State laws vary widely; for example, in Florida, shipment can be done without a death certificate or a transit permit, so long as a mortician is confident that this was not a case of unnatural death, and documentation will follow. In California, a death certificate and a transit permit are mandatory before shipment can be done legally, and obtaining these documents can be a time-consuming process, especially on evenings or weekends.

However, Alcor received legal advice in 2010 which we interpret to confirm that a cephalon may be considered an anatomical donation, enabling it to be transported across state lines without a transit permit while the body, as human remains, waits for any permits that are required, or may be conventionally interred or cremated in the state where death was pronounced. Therefore if neuroseparation can be performed in the state where legal death occurs, and if it is consistent with the patient's wishes, this can be a major advantage in completing a transport as quickly as possible.

## **Addendum**

### **Choosing and Equipping a Transport Vehicle**

#### **Buying a Vehicle for Alcor**

For many years, Alcor used a refurbished ambulance for local ground transport (see Figure 17-7). This continued until November, 2002 when it was deployed for transport of a patient from a suburban home to the Alcor facility just three miles away. When the patient was pronounced, the ambulance refused to start.



*Figure 17-7. This refurbished ambulance was used at Alcor until the end of 2002.*

A quick decision was made to move the patient to Alcor in a different vehicle, even though cooling would not be available during the journey. Getting the patient to the facility as rapidly as possible was seen as being more important than trying to make other arrangements, especially as the operating room at Alcor was ready and waiting.

Alcor had to replace the ambulance as quickly as possible, and in the interests of reliability, the vehicle would be new, not second-hand. Because this was a significant expenditure and would affect cases for years to come, many people participated in the decision.

A new ambulance was prohibitively expensive, and was not entirely compatible with the needs of cryonics cases anyway. The space inside an ambulance tends to be limited, and there are features that a cryonics organization doesn't need, such as a large steel compartment for an H-sized cylinder of oxygen.

Alcor staff investigated the option of a step van. This type of vehicle has a sliding driver's door and is often seen making deliveries for United Parcel Service. However, the step-van design does not seem to have improved for many decades, and would require a lot of upgrades to make it comfortable for significant distances.

The Alcor staff decided that a typical cargo van would not be large enough. In the end, they chose a 16-foot box truck. This type of vehicle is manufactured as a cab and bare chassis, after which a conversion company mounts a box-shaped cargo section on the back. The cargo section typically has a wooden floor and wooden interior frame. The vehicle that Alcor acquired is shown on the dealer's lot in Figure 17-8, and its interior is shown in Figure 17-9.



*Figure 17-8. A box truck purchased for Alcor. It became a cryonics transport vehicle that is still currently in use.*



*Figure 17-9. The interior of Alcor's vehicle, before conversion began.*

Many box trucks do not have any communicating door between the load area and the cab. This feature is referred to as a “cutaway” and was considered essential, so that team members could take turns in the roles of driver, passenger, and patient supervisor with minimal inconvenience.

Any person with a driving license may drive a box truck. A heavy-vehicle license is not required.

Advantages of a box truck include:

- Relatively low cost.
- Relatively easy to maintain and repair.
- Unobtrusive (the default color of a new truck is white).
- Interior typically allows everyone to stand instead of having to stoop.
- Sufficient ground clearance to install accessories under the floor, such as a large generator and batteries.

Disadvantages of a box truck include:

- Difficult to park.
- People who lack experience with large vehicles may find it difficult to drive.
- Usually too tall for a parking garage.
- Relatively noisy for long journeys.
- Not a very smooth ride.
- Air conditioning for the box section is a high-cost aftermarket option.
- Heat insulation must be added in the box section.

The box truck was converted at Alcor, but the conversion was not considered entirely satisfactory. It was stripped out and replaced in 2010 by

Steve Graber, Alcor's Technical & Readiness Coordinator. Photographs of his work are shown in figures 17-10, 17-11, and 17-12.



*Figure 17-10. Interior of the Alcor patient transport vehicle with one seat folded up to allow the ice bath to be loaded.*



*Figure 17-11. Storage at the rear of the Alcor patient transport vehicle.*



*Figure 17-12. The ice bath loaded into the Alcor vehicle, and the seats folded down.*

## **Buying a Vehicle for Suspended Animation**

Suspended Animation addressed the need to acquire a vehicle for patient transport after a change of management in 2004. Mindful of the negative attributes of a box truck, employees tried to think of other options.

The Dodge Sprinter had recently been introduced, and its specification looked promising. It was taller-than-average cargo van, and was available in a long version that might provide enough space for a transport kit, consumables, and an ice bath, with possibly enough room to perform procedures. The Sprinter (which is actually a Mercedes, behind the Dodge nameplate) was quieter and much easier to drive than a box truck, with a softer ride.

A second option was a shuttle bus of the type that typically picks people up from an airport terminal and drives them to a parking garage or car-rental agency. An example is shown in Figure 17-13. Shuttle buses are easy to drive, have a gentle ride, and are easy to access, because they have a relatively low ground clearance. A company was located that would equip a bus with any configuration that a customer wants. The company reduced its usual charge



when Suspended Animation specified a vehicle with no windows, no seats, no front steps and folding door, and no custom exterior paint (just plain white).



*Figure 17-13. A shuttle bus in a typical configuration.*

The choice between a Sprinter van or shuttle bus was presented to Bill Faloon of Life Extension Foundation, which was underwriting Suspended Animation. After a brief assessment, Faloon approved purchase of both.

Suspended Animation went ahead and acquired both vehicles. The shuttle bus is shown on its day of delivery in Figure 17-4.



*Figure 17-14. The shuttle bus delivered to Suspended Animation*

## **Converting a Vehicle After Acquisition**

Specifics of vehicle conversion turned out to be a cause of lengthy disagreements, both at Alcor and at Suspended Animation. The details would take too much space here, but some salient points can be summarized.

### *The Ice Machine*

Local availability of cubed ice is one of the few requirements that has never been a problem in any standby in the United States. Ice is ubiquitous, cheap, and plentiful. Nevertheless, when Alcor addressed the challenge of outfitting its box truck, a senior employee at Alcor wanted to install a full-size, commercial-grade ice machine.

Ice machines are designed for installation in bars and restaurants where size, weight, and power consumption are not sensitive issues. Ice machines also consume water on a constant basis, and emit a lot of waste heat. Still, the initial conversion of the Alcor vehicle did include an ice machine, together with a very large generator, a very large water tank, and some huge battery packs.

After the employee moved on, new management at Alcor decided that the ice machine should be removed.

### *Side Door or Rear Door*

A major advantage of a side door is that it opens directly onto the sidewalk from a parked vehicle. Many vans include side doors for this reason.

If a fully loaded ice bath has to be loaded into the rear door, the ice bath must be moved down off the curb and onto the street, then up onto the platform of a lift gate. This will require at least two people, and preferably three.

Rear access also requires ample space behind the vehicle—hence the “keep back” signs on ambulances. If personnel leave a cronics transport vehicle to collect a patient from inside a hospice, and if someone parks behind their vehicle while they are away, they will be unable to load the patient when they return.

At Suspended Animation, both vehicles initially were configured using their side doors. This in turn required the use of ramps, because lift gates cannot be installed on side doors.

### *Ramp or Lift Gate*

Professional movers typically like to use a ramp when loading or unloading a truck, because it's quicker to use than a lift gate, does not run down the battery, and in some respects can be safer. However, for a box truck, the load bed is so high off the ground, a ramp must extend outward a long way—otherwise, its gradient will be too steep. Consequently lift gates are often found on box trucks, and the substantial extra weight is well within the design limits of this kind of vehicle. For cryonics cases, the only concern is that the lift gate should be large enough for an ice bath, and rated to lift the substantial weight of the ice bath with ice, water, and patient.

Alcor's box-truck transport vehicle uses a lift gate.

At Suspended Animation, a ramp was custom-built in-house and installed on the Sprinter, as shown in Figure 17-15. (This photograph also shows a small door near the rear of the vehicle, which was being installed to allow access to two 1,000-watt Honda generators.) To assist with the challenge of pushing a fully loaded ice bath up a ramp, a winch was also installed. To allay concerns about water splashing out of a tilted ice bath, a leveling device was used, consisting of two wheels on an axle, a vertical handle, and a bar that extended horizontally at the bottom. The bar was engaged in the bottom of the ice bath, and someone pulled back on the handle, much like a delivery person using a hand truck. The leveler was suggested by a staff member with experience moving heavy objects in industrial environments.



*Figure 17-15. Custom-built aluminum ramp extended from the side door of the Sprinter van acquired by Suspended Animation.*

Using this equipment, two people could load the vehicle fairly easily. There was some concern about the winch motor, which showed sparking around its armature, but the fire risk was eliminated when Suspended Animation replaced its oxygen-driven Thumpers with the electrically-powered Autopulse.

Access through the side door sacrificed some storage space, but it was regained by blocking off the rear doors so that equipment could be stacked there. The snug space inside the Sprinter when a portable ice bath has been wheeled into it is shown in Figure 17-16.



*Figure 17-16. The interior of the Sprinter van after its initial conversion at Suspended Animation. The walls have been panelled with washable plastic, and LED lighting has been installed. An aftermarket air conditioner is visible in the roof.*

The side door of the shuttle bus presented more of a challenge, as the bus was higher off the ground than the Sprinter. The ramp was steeper, and a more elaborate leveler was required, as shown in Figure 17-17. This did allow the vehicle to be loaded by just one person using a remote control for the winch, but looked unsafe to anyone who had not used it.



*Figure 17-17. With a remote-controlled winch and a levelling linkage, the Suspended Animation vehicle could be loaded by one person through its side door, but the arrangement was not popular.*

Disagreements regarding doors and ramps continued until Catherine Baldwin became the general manager of Suspended Animation. At that point, lift gates were installed on both vehicles, even though the Sprinter was not really designed for so much weight behind the rear wheels.

In Europe, many ambulances are equipped with ramps. An example was bought by Alan Sinclair as part of his equipment for Alcor UK.

Because the rear suspension of the ambulance is designed so that it can be lowered, the ramp can be very short. However, the interior of this type of vehicle allows very limited space.

Figure 17-18 shows the ambulance with its rear suspension lowered, Figure 17-19 shows the interior viewed through the rear door, and Figure 17-20 shows the very small ramp unfolded so that a wheeled stretcher can be rolled right in.



*Figure 17-18. The ambulance converted by Alan Sinclair in the UK, shown with its rear suspension in the lowered position.*



*Figure 17-19. Interior of the ambulance converted by Alan Sinclair.*



*Figure 17-20. The ramp folded down in Alan Sinclair’s ambulance.*

### *Suspended Animation Experience*

In 2014, Catherine Baldwin shared the experience she had acquired with the vehicles at Suspended Animation since she took over in 2007. She wrote: “In 2009-2010 the E450 [shuttle bus] vehicle in FL was stripped to the frame, updated and refurbished—floors, walls, ceiling, electrical, plumbing, seating, general lighting, cameras, A/C. In 2011 the Sprinter in CA was stripped to the frame, redesigned and refurbished—floors, walls, ceiling, electrical, ambient and surgical lighting, cameras, ice bath mounts, storage cabinets, rear lift gate. Both vehicles now provide stand-alone support for stabilization, including femoral or thoracic access surgery, perfusion and neuroseparation.”

She noted that re-renovating the vehicles had been preceded by trials using swine cadavers to simulate patient procedures.

“Medical professionals are impressed by our equipment,” she continued. “Giving them a quick tour before a case has helped our credibility on cases.



We have also had requests to build vehicles for coroners and disaster response teams.”

As of January, 2014 Baldwin reported that the shuttle bus had been used for five cryonics cases involving surgery and blood washout, and 26 regular practice sessions with swine cadavers. The Sprinter had not been equipped for surgery and perfusion until the end of 2011, and had been used for surgery and washout in one case by 2014.

When asked which vehicle she preferred, she seemed to have difficulty choosing between the nimble handling of the Sprinter and the extra interior space on the shuttle bus.

The ideal cryonics transport vehicle may not yet exist, but experience has certainly shown that conversion can end up costing considerably more than anyone initially expects.

### *Conversion Decisions*

Some of the fundamental issues that have to be resolved when planning a transport vehicle include:

**Air conditioning.** Should it run from a separate compressor added to the engine? This is typical on box trucks, but may not be possible or appropriate on smaller vehicles. On the Suspended Animation Sprinter, two small Honda generators were installed in conjunction with an aftermarket air conditioner on the roof. In the shuttle bus, air conditioning sufficient for the entire vehicle was a standard item installed during the conversion.

**Heat insulation.** The load area of a truck or van is not normally insulated, but has to be, for cryonics transport. Figure 17-21 shows the Sprinter being insulated with foil-coated foam board.



*Figure 17-21. Installing insulation during initial conversion of the Suspended Animation Sprinter van.*

**Ventilation.** Fans may be necessary in the load area.

**Air filtration.** A HEPA unit may be advisable, bearing in mind the possible risk of transporting patients who have died of communicable diseases.

**Plumbing.** A sink will be necessary, with a pump, a water tank, and a waste-water tank. Should a chemical toilet be installed? Should a mini-shower be added?

**Folding seats for long journeys.** The staff in the rear of the vehicle cannot stand up all the time.

**Lighting.** Must be sufficient not only for emergency procedures, but for surgery. Should it run off 12VDC or 110VAC?

**Refrigeration.** Some medical supplies must be kept cool. A few must be kept frozen. Refrigeration should be minimized, as it will create waste heat. Should a propane-powered refrigerator be used?

**Power.** If a generator is installed, it must run quietly to avoid attracting unwanted attention. Some generators are so quiet, they are certified as suitable

for use in national parks. A separate battery supply may be considered necessary, with a large inverter.

When considering these issues, experienced advice will be extremely helpful, and a good starting point may be one of the many conventions or fairs that are held for owners of recreational vehicles. Every conceivable type of vehicle has been adapted and modified by enthusiasts in the RV community, and they are generally eager to share their knowledge.

As always in cryonics, it is wise to avoid reinventing the wheel.



# Remotely Assembled Dry Ice Shipment Packaging

Report: Matthew A. Schultz  
Regina M. Pancake

Design: Hugh Hixon, Jr.  
Alcor Life Extension Foundation  
Tuesday, March 31, 2009

**Contents**

Required Materials ..... 1

Packaging the body ..... 4

Shipping Assembly ..... 5

    Step 1: Unpack the Air Tray ..... 5

    Step 2: Apply the Base Insulation Layer ..... 5

    Step 3: Add the Surrounding Insulation ..... 5

    Step 4: Apply the Siding ..... 6

    Step 5: Cover the Case With Insulation ..... 6

    Step 6: Add the Final Layer of Insulation ..... 6

    Step 7: Close the plastic wrap ..... 7

    Step 8: Close the case ..... 7

Physical Dimensions ..... 8

Shipping Times and Dry Ice loss over Time ..... 9



## Required Materials

The dry ice shipper requires the following materials to assemble:



### Ziegler Case

Standard shipping component.



### Air Tray

Standard shipping assembly.



### R-19 Insulation

Standard R-19 fiberglass insulation. 6.25" (16cm) thick and 15" (38cm) wide. This project requires about 62 feet (18.9 meters) of insulation material. Gloves are recommended, but not required for handling this material.





### Duct Tape

Used for internal packaging. Packaging tape or other strong tape may work.



### Dry Ice

Keeps the core temperature of the patient down. Dry ice in pellet, rice, powder, or other particle form is preferable, as blocks will need to be broken up.



### Gloves

Suggested to reduce contact with the fiberglass insulation material, which may be irritating to the skin.



## Plastic Drop cloth

A plastic sheeting to help hold everything in place. .7 MIL is recommended, minimum 9 feet (2.75 m) x 12 feet (3.7 m).

## (2x) Support Piece

Small sections of support for the bottom of the Ziegler case. Wooden 2x2's are recommended, but any similar material should work. Each piece should be between 1 and 2 feet (30 to 60 cm) long. They serve to prevent the Ziegler case from flattening the insulation below it.





## Packaging the body

The body is packaged with the dry ice inside the Ziegler case for shipping. The mortician should handle most if not all of this part.

The first step is to lay down a base layer of dry ice. The patient is then laid onto the base layer of ice, and then the container can be filled with ice. If limited by weight, the container can be left partially full, but for ideal shipment, the case should be filled to the top.

Once the patient is placed in the case, on dry ice, some time should be allotted for the temperature of the patient to lower to the required temperature for shipment. After placing the patient in the case, close, but do not seal it. Allow 24-48 hours (48 hours being ideal) for the patient to cool down to the temperature of the dry ice (-78°C). Once this time has passed, re-fill the case with dry ice and seal for shipment.

The maximum shipment time is given by the total amount of dry ice initially placed into the shipping container at the start of the shipment.



## Shipping Assembly

Once the body has been packed in the Ziegler case for shipping, the shipping container can be assembled.



### Step 1: Unpack the Air Tray

Remove the packaging from the air tray. Set the cardboard sleeve and cardboard top aside for later use. The wooden baseboard of the air tray should now be on the ground, the straps on the sides for refastening.

### Step 2: Apply the Base Insulation Layer

Lay the plastic sheet into the wooden component of the Air Tray. Cut two strips of insulation the length of the tray, and lay them down side by side forming the base layer of insulation. Place the two supports equidistant from the in the center of this insulation, preventing the case from flattening the insulation below.



### Step 3: Add the Surrounding Insulation

Place the Ziegler case onto the insulation layer, on top of the two supports. Wrap insulation material all around it. Tape the ends together to hold it on. The material should extend upwards from the top.



#### Step 4: Apply the Siding

Pull the plastic sheeting up over the sides of the insulation, wrapping the insulation in plastic. Slide the cardboard sleeve onto the top of this, over the outside of the plastic. Assure that the cardboard passes inside the lip of the wooden base.



#### Step 5: Cover the Case with Insulation

Add a strip of insulation about the length of the Ziegler case to the top of the case.



#### Step 6: Add the Final Layer of Insulation

Apply two additional strips of insulation to the top of the case, mirroring the bottom layer.





### Step 7: Close the plastic wrap

Wrap the plastic over the top of the insulation and tape it closed.

### Step 8: Close the case

Add the cardboard top to the case, then attach the straps, sealing the case.



## Physical Dimensions

Weight Empty	135.5 pounds (32.37 kg)
Weight Capacity (recommended)	500 pounds (226.80 kg)
Weight Capacity (maximum)	1000 pounds (453.59 kg)
Length	88" (223.5 cm)
Width	30.5" (77.5 cm)
Height	20.5" (52 cm)



## Shipping Times and Dry Ice loss over Time

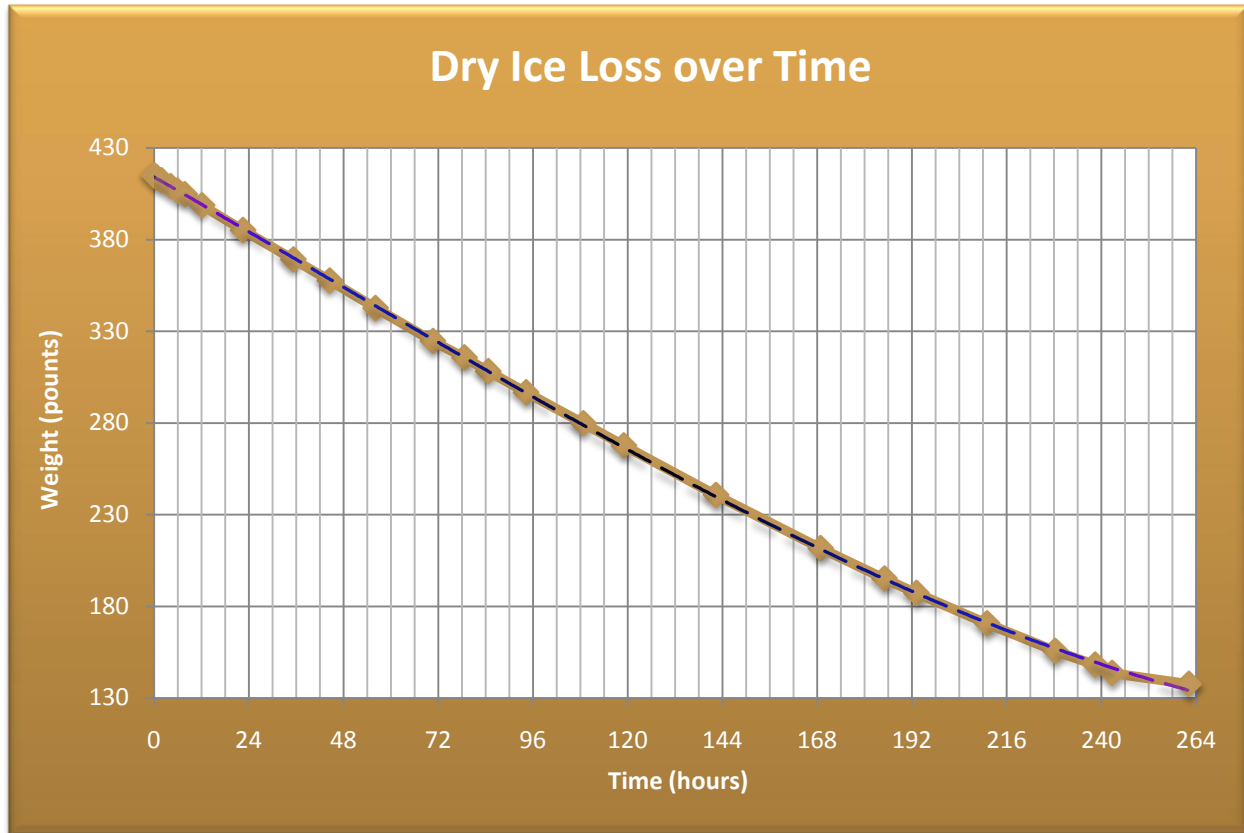

The patient should arrive with at least 30 – 50 pounds (13.6 to 22.7 kg) of dry ice remaining to assure ideal temperature is maintained. Dry ice is lost at an approximate weight of 30 pounds per day. Therefore, the absolute maximum transit time is calculated by the formula  $\text{Time}_{(\text{days})} = (\text{Weight}_{(\text{pounds})} / 30)$ . This should assure the patient maintains optimum temperature during transit. In all cases, where possible, the transit time should be reduced to as short as possible, and the amount of dry ice included in the Ziegler case should be as great as possible, thus allowing for unforeseen delays or extenuating circumstances.



## **18. Cryoprotection**

Cryoprotective perfusion is the most crucial phase of human cryopreservation procedures. If cryoprotective perfusion is compromised, freezing will produce extensive damage to the fine structure of the brain of the patient, regardless of the quality of the cryonics organization's standby and stabilization efforts. Since its inception, most sensible advocates of cryonics have, therefore, always recommended some form of cryoprotection to mitigate ice formation during storage at a low temperature. Since the year 2000, the Alcor Life Extension Foundation introduced vitrification as an alternative to conventional cryopreservation with the aim of abolishing freezing altogether. In this section, we will discuss aims of cryoprotective perfusion, the history of its technologies and protocols at Alcor, and special applications such as whole body cryopreservation or field cryoprotection.

### **Objective**

The objective of cryoprotective perfusion is to replace blood and the liquid parts of cells with a solution of cryoprotectant agents (CPAs) to reduce or, ideally, eliminate freezing damage when the body or brain is cooled below 0 degrees Celsius. To this purpose vascular access is obtained and perfusion technologies are used to introduce the CPA solution of choice such that the concentration of CPA ingredients increases with time while the temperature of the patient is reduced. Measurements at the venous side of the patient are used to determine when the target concentration of the CPA solution has been reached inside the body.

After completion of cryoprotectant perfusion the patient is gradually cooled below the glass transition temperature ( $T_g$ ) for long term care. While some patients at Alcor are maintained at a temperature between  $T_g$  and liquid nitrogen, the great majority of patients at Alcor and other cryonics storage

facilities have been immersed in liquid nitrogen at a temperature of –196 degrees Celsius.

See Section 20 for more information about the maintenance of cryopatients.

## **Cryoprotectant Solutions**

Cryoprotectant solutions contain a variety of ingredients that serve different purposes. All cryoprotectant solutions contain a particular set of ingredients that together comprise a carrier solution, also called a vehicle solution. Carrier solution ingredients are not considered to be cryoprotectants. Most carrier solution ingredients remain at constant concentration while the concentration of cryoprotectant ingredients (CPAs) in the solution changes during a cryopreservation process.

The carrier solution ingredients are all “non-penetrating,” which means that they don’t penetrate cell membranes because they are either large molecules or ionically charged small molecules. Carrier solution ingredients include pH buffers (usually adjusted to make a solution pH of 8) and osmotic agents to give the solution a tonicity near 300 milliOsmolal (excluding CPAs) so that cells don’t osmotically swell to larger than their normal volume during a cryopreservation process. The carrier solution may also contain small concentrations of calcium and magnesium ions to stabilize cell membranes. However the concentration of calcium and magnesium is lowered as CPA concentration increases. Otherwise these ions tend to precipitate in the presence of high concentrations of CPA ingredients.

CPAs (cryoprotective agents) are the ingredients of a cryoprotectant solution that are specifically included to inhibit ice formation. During circulation of cryoprotectant solution through blood vessels (perfusion), the concentration of CPA ingredients is increased until a desired target arterial concentration is reached.

There are two types of CPAs, penetrating and non-penetrating.

**Penetrating CPAs** are small uncharged polar molecules, typically of molecular weight less than 90, that are small enough to penetrate cell membranes (typically through aquaporin channels) on a timescale of minutes.



When exposed to penetrating CPAs, cells initially shrink as water rushes out of the cell in response to the osmotic stress of the CPA outside the cell. Over several minutes, intracellular and extracellular concentrations of CPA equalize by diffusion, and the cell returns to normal volume (as dictated by the tonicity of the carrier solution). During perfusion, cell dehydration in response to increasing CPA concentration manifests as dilation of blood vessels, causing a decrease in vascular resistance, causing an increase in solution flow if perfusion pressure is held constant. This flow increase is most likely to be seen at the beginning of a cryoprotectant perfusion ramp (“ramp” means planned increase in CPA concentration over time), when even a small change in CPA concentration causes a large proportional change in extracellular solution tonicity.

**Non-penetrating CPAs** are large molecules, typically polymers, that are too large to penetrate into cell interiors. By penetrating through capillary gap junctions (but not cells), non-penetrating CPAs provide extra protection against ice formation in the extracellular space of tissue. This extra protection is needed because ice has a greater tendency to nucleate (initially form) outside cells than inside cells, and cytoplasm inside cells has its own natural polymers that in combination with penetrating CPAs help protect against ice formation.

For more information about cryoprotectants, how cryoprotectant technology has advanced, and the difference between freezing and vitrification, see the article “How Cryoprotectants Work” in *Cryonics* magazine, 3rd Quarter 2007, archived on the Alcor web site.

## **Cryoprotectants at Alcor**

Since its inception Alcor has been guided by theoretical and practical cryobiology research to incorporate the most promising developments in mitigating ice formation. Initially DMSO was Alcor’s cryoprotectant of choice, reflecting the general popularity of DMSO as a cryoprotectant in the 1960s and its (reported) superior ability to penetrate cells. For example, 5% of DMSO, followed by 20% DMSO in modified Collins solution, was used to perfuse Frederick Chamberlain, Jr. (Alcor’s first neuropatient) in 1976.

Around 1977, following an extensive correspondence between Michael Darwin and Jerry Leaf, Alcor decided to switch from the use of DMSO to glycerol based on several observations that even low concentrations of DMSO increased whole body edema in cryonics patients. Concentrations of glycerol were chosen to satisfy the so-called Smith Criterion, i.e. Audrey Smith's discovery that golden hamsters could survive 60% of the water in their brains being converted into ice with no ill effects. In 1992, a consulting cryobiologist recommended to take the glycerol concentration as high as possible. Since glycerol has a high viscosity at low temperatures, in practice this recommendation translated in a target concentration range between 7.5M and 8.0M, which in combination of the glycerol-induced dehydration of the brain inhibited most, but not all, ice formation.

From the year 2000 Alcor announced switching from high molarity glycerol to a new generation of vitrification agents designed by the cryobiology company 21st Century Medicine, modelled after its vitrification agent VM3 (see Section 1). The first two agents were named B1C and B2C. B1C and B2C were the first "hyperstable" vitrification agents used at Alcor and formulated to inhibit ice formation at relatively low cooling rates (~ 0.1 degree C per minute). B1C was only used in a few of cases and was shortly replaced by B2C which increased the concentration of penetrating components relative to polymers to reduce viscosity. Due to concerns about whole body edema and the need to develop new equipment for cooling whole bodies at the faster rates preferred for vitrification, B2C was only available for neuro-preservation cases.

In 2005 Alcor introduced 21st Century Medicine's low toxicity vitrification solution M22, thereby closing the gap between the state of the art in mainstream cryobiology for the vitrification of complex mammalian organs, and cryoprotectants used in cryonics. M22 was Alcor's first solution with backing in the peer reviewed literature for recovering kidneys from -45 degrees C and good ultrastructural brain vitrification. Additives also allowed whole body perfusion, which made vitrification available for all Alcor members who had elected whole-body preservation as opposed to neuropreservation. See Table 18-1 for a history of Alcor cryoprotectants.

Year	Cryoprotectant
1976	20% DMSO
1980	3.0M Glycerol
1987	4.5M Glycerol
1992	8.0M Glycerol
2001	B1C (neuro only)
2001	B2C (neuro only)
2005	M22 (separate neuro and whole body formulations)

Table 18-1. History of cryoprotectants used at the Alcor Life Extension foundation.

## M22 Cryoprotectant

To understand cryoprotectant design, we reproduce the formula of M22 in Table 18-2 and will discuss its individual components and design principles.

Dimethyl sulfoxide	22.305% w/v
Formamide	12.858%
Ethylene glycol	16.837%
N-methylformamide	3%
3-methoxy-1,2-propanediol	4%
Polyvinyl pyrrolidone K12	2.8%
X-1000 ice blocker	1%
Z-1000 ice blocker	2%

Table 18-2. Composition of M22 cryoprotectant solution at full strength, also called "1x" concentration or CNV (concentration necessary to vitrify). During

*cryoprotective perfusion, the concentration of M22 ingredients increases from zero to full strength. Not shown are vehicle solution (aka carrier solution) ingredients that remain at constant concentration during perfusion.*

The name of M22 refers to -22 degrees C, which is the temperature at which the full-strength solution is perfused into kidneys in published organ cryopreservation experiments. The core components of M22 are the penetrating cryoprotectants DMSO, formamide, and ethylene glycol. The equimolar DMSO and formamide combination reflects cryobiologist Gregory Fahy's discovery that DMSO can neutralize the toxicity of formamide. The weak glass former ethylene glycol is added to this essential non-toxic core of DMSO and formamide to further increase cryoprotectant concentration. While methylated cryoprotectants like n-methylformamide and 3-methoxy-1,2-propanediol exacerbate cryoprotectant toxicity in high concentrations, in small concentrations they can improve the solution's resistance against ice formation and reduce viscosity. Addition of the non-penetrating cryoprotectant PVP K12 reflects the fact the intracellular environment of the cell is more resistant to freezing than the extracellular environment, and thus can tolerate a slightly lower overall cryoprotectant concentration. X-1000 (a co-polymer of polyvinyl alcohol ) and Z-1000 (polyglycerol) are 21st Century Medicine's propriety "ice blockers" which reduce the concentration necessary to vitrify and critical cooling rate by inhibiting ice nucleation generally (X-1000) and ice nucleation due to protein contamination specifically (Z-1000).

The vehicle solution for M22 is called LM5 to reflect the 50% reduction of glucose (as compared to the older vehicle solution RPS-2) in favor of equimolar concentrations of lactose and mannitol, to solve compatibility problems with the ice blockers. LM5 works together with the non-penetrating CPA components to create an overall hypertonic solution that is effective in mitigating "chilling injury." At Alcor a minor adjustment of LM5 named B1 is used for cryopreservation, which includes an additive to inhibit swelling during cryoprotective perfusion. B1 is also the washout solution that precedes the start of cryoprotectant perfusion. See Table 18-3.

The initial stage of cryoprotective perfusion is conducted with an arterial perfusate temperature close to +3 degrees Celsius. When the concentration of

M22 ingredients reaches 50% of CNV (Concentration Necessary to Vitrify), as measured by the venous refractive index, the temperature is dropped to about  $-3$  degrees Celsius and the concentration of M22 ingredients is quickly ramped up to 100%.

Chemical	MW	Molar Conc.	Grams/Liter
Glucose	180.16	90 mM	16.214
Mannitol	182.17	45 mM	8.198
Alpha-Lactose Monohydrate	360.31	45 mM	16.214
Potassium Chloride	74.55	28.2 mM	2.102
Potassium phosphate dibasic trihydrate	228.22	7.2 mM	1.643
Gluthathione (reduced)	307.32	5 mM	1.537
Adenine HCl	171.59	1 mM	0.172
Sodium Bicarbonate	84.01	10 mM	0.840
Calcium Chloride Dihydrate			0.147
10% w/v	147.01	1.0 mM	1.47 ml
Magnesium Chloride Hexahydrate			0.407
20% w/v	203.3	2.0 mM	2.035 ml
Proprietary Additive			

*Table 18-3. Components of B1 vehicle solution used at Alcor. B1 consists of the LM5 vehicle solution developed by 21st Century Medicine, Inc., for kidney cryopreservation plus a proprietary additive. The concentration of the LM5 vehicle solution ingredients doesn't change as the concentration of the M22 ingredients of Table 2 increases during cryoprotective perfusion.*

## **Cryoprotectants and the Brain**

The fact that perfusion of the brain with cryoprotectants causes the brain to physically shrink has been known in cryonics since cryonics organizations started using burr hole observations to evaluate the effects of cryoprotectant perfusion. This shrinkage is often called dehydration, although technically all tissue treated with cryoprotectants dehydrates (loses water) whether it shrinks or not. The cause of this shrinkage is that most cryoprotectants have poor blood brain barrier (BBB) permeability. The usual cryobiological “shrink

swell” response of tissue in response to CPA exposure as water first leaves tissue by osmosis (shrink) and is then replaced by CPAs by diffusion (swell) is mostly just “shrink.” Glycerol in particular has been associated with severe brain dehydration (except in canines, the brains of which appear to be anomalously permeable to CPAs when pets are cryopreserved). Most of the penetrating cryoprotectants in M22 have relatively slow BBB penetration. PVP K12 and the ice blocker ingredients of M22 are presumed to not penetrate the BBB at all.

HPLC studies (unpublished) do show significant penetration of the low molecular weight CPA components of M22 into the brain, but not at a rate sufficient to prevent brain shrinkage during perfusion. Since there are no open capillary gap junctions in the brain (the definition of the blood brain barrier), penetration of CPAs into the brain is presumed to occur directly through capillary endothelial cells, with cryoprotectants entering endothelium cells on the intravascular side and exiting on the extravascular side following diffusion gradients from high to low concentration.

The inability of the non-penetrating CPAs to leave brain blood vessels, and limited penetration of other CPAs into the brain, should not be interpreted to mean that the brain isn’t cryoprotected by perfusing cryoprotectant solutions through it. Water moves readily across the BBB in response to “water activity” gradients (osmosis). The temperature at which ice would melt in a solution is one way of measuring water activity. When a solution with a low melting point, such as M22 with a melting point of -55 degrees C, is perfused through brain blood vessels, water is drawn from brain tissue into the blood vessels following the gradient of high water activity in the brain to low water activity in the vessels. Water will continue to leave tissue and increase the concentration of solutes in tissue until at equilibrium the water remaining in brain tissue has the same low melting point as the solution in the vessels.

This loss of water and resulting melting point depression makes brain tissue more resistant to ice formation. Differential scanning calorimetry (DSC) study of tissue samples from brains perfused with M22, and microscopy studies of whole brains cryopreserved after perfusion with M22, confirm that perfusing brains with M22 for approximately 60 minutes at a temperature near 0 degrees C is sufficient to completely inhibit ice formation at lower

temperatures at typical cryonics cooling rates. In other words, a brain perfused with M22 under optimal conditions can be vitrified despite limited penetration of CPAs through the BBB. The cryoprotection that makes this possible is believed to be a result of the combined effect of penetrating CPAs that reach brain tissue and natural solutes in the brain (proteins and salts) whose concentration is increased by cell shrinkage as water leaves the brain in response to water activity gradients.

Warm or cold ischemia tend to eliminate brain shrinkage in response to cryoprotectant perfusion, presumably because ischemia compromises the BBB in a time-dependent manner. The compromised BBB allows CPAs to enter tissue faster so more of the water that leaves the brain can be replaced by CPA molecules, resulting in less shrinkage. One (ironic) consequence of this is that in cryonics severe dehydration (shrinkage) during cryoprotectant perfusion is often an indicator of good patient care (i.e. minimization or mitigation of ischemia).

In local Alcor cases that have been conducted under good conditions, severe dehydration was often observed through the burr holes. Recent Computer Tomography (CT) scans performed for Alcor have show the dehydration even more clearly. CPA-induced brain shrinkage can reduce brain volume by almost 50%. See Figure 18-1.

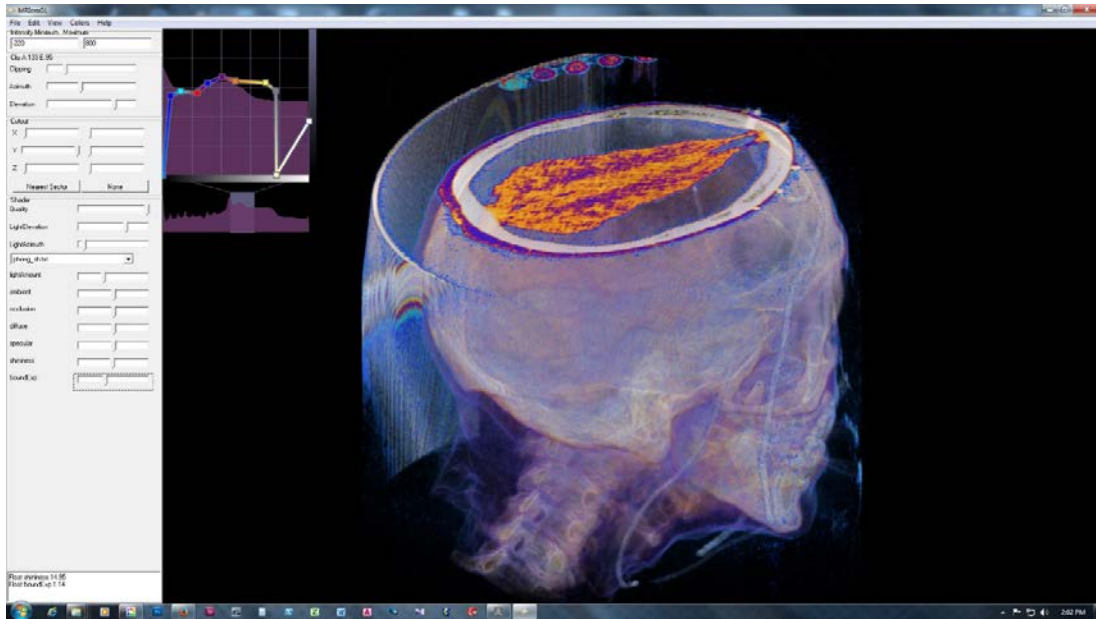

*Figure 18-1. CT Scan of Alcor patient showing cryoprotectant-induced brain dehydration (orange area).*

Cerebral dehydration (shrinkage) was identified as a potential form of injury in a case report for patient A-1097 (2006). At the Cryonics Institute, Yuri Pichugin also demonstrated that the extreme dehydration associated with modern vitrification solutions is not compatible with good brain slice viability. This is consistent with cryobiological theory, in which one of the ways that penetrating cryoprotectants are known to protect cells during cryopreservation is by preventing freezing-induced elevation of natural salts and proteins inside cells. (It is less toxic to cryoprotect cells by replacing water inside them with artificial CPAs like ethylene glycol than by removing water to increase concentration of natural salts by shrinkage.) Another reason that shrinkage is undesirable is that the appearance of shrunken brain tissue in electron micrographs is difficult to interpret and compare with control micrographs. In the case of M22, perfusion unloading has been shown to restore a more normal appearance of cells. However it would be desirable to minimize shrinkage during the entire cryopreservation process, especially if doing so mitigates toxicity as expected.



Osmotic opening of the BBB with molecules such as mannitol have a transient effect on BBB permeability but do not seem potent enough to permit brain cryoprotection without dehydration. The most promising approach at the moment is to use a BBB modifier to cryoprotect the brain without shrinking. Unpublished research has demonstrated the efficacy of adding a small concentration of detergents like SDS (sodium dodecyl sulfate) to the perfusate, a technique first pioneered by Yuri Pichugin at the Cryonics Institute. If there are no serious toxicity effects this would be a solution that Alcor could adopt in the future if a way can be found to adjust for effects of different amounts of cerebral ischemia prior to perfusion so that edema (brain swelling) would not result.

## **Cryoprotective Enclosure Design**

Cryoprotection requires a stable and dedicated environment to conduct perfusion. The most basic incarnation of this idea is to use a surgical table to do both surgery and cryoprotection. The patient can be surrounded by ice packs during surgery and perfusion and after completion moved to a cooling box for cooling to liquid nitrogen temperatures.

Alcor uses a more sophisticated whole body patient enclosure that allows for surgical procedures, cryoprotection procedures, monitoring, and cooling. See Figure 18-2. This enclosure minimizes patient handling, cooling can be switched on or off in sectors for surgery visibility, cryoprotection and (initial) deep cooling are done in the same environment.



*Figure 18-2. Whole Body Perfusion Enclosure.*

This enclosure employs intermittent injections of nitrogen gas to maintain cold temperatures that are appropriate for different stages of cryoprotective perfusion, including temperature below 0 degrees C during later stages.

The enclosure has two independent cooling stages. First is a thin cold stage, constructed of a conductive metal. Cold vapor circulates from foot to head and returns in a counter-current manner within the cold stage, equalizing the temperature gradient along the length of the table. The vapor is contained in the cold stage, and not vented into the patient space, allowing cooling to

occur without any vapor to obscure vision. Second, vapor is circulated laterally through the patient compartment. This is divided into 4 independently-controllable zones, roughly corresponding to the legs and feet, groin, chest, and head, allowing independent access for femoral, thoracic, and head/neck surgery. Access is also provided to drill burr holes during perfusion and cooling. Temperature control is through Omega controllers, connected by Ethernet to the central computer system for monitoring and changing set points. If the central computer fails, the controllers will maintain the last set temperature.

The interior space of the cooling enclosure is constructed to match exactly the dimensions the whole body pods. This allows for optimal deep cooling in the same enclosure and will enable Alcor to immediately know if the size of the patient will create a problem for the typical storage pod.

The acrylic enclosure is secured on top of a stainless steel frame, constructed to fit on top of the surgical table. The frame prevents flexing of the acrylic top, and provides space for mounting equipment needed for the table. Data collection is mounted onto the frame, along with suction, electrocautery, and a gas manifold for pneumatic surgical and includes an uninterruptible power supply, allowing function to continue without power at least long enough to start our emergency generator.

The current whole body enclosure can drop to  $-110$  degrees C and can be used for rapid cooling. Since there is no need to move the patient to a different cooling system, this enables commencement of deep cooling immediately after cryoprotective perfusion ends. The table can also be rolled to the cooldown bay during the latter portion of cooling if the OR is needed for another case.

Alcor has also developed a “neuro” enclosure with similar properties to be used during cryoprotective perfusion of neuropatients, which can be seen in Figure 18-3.

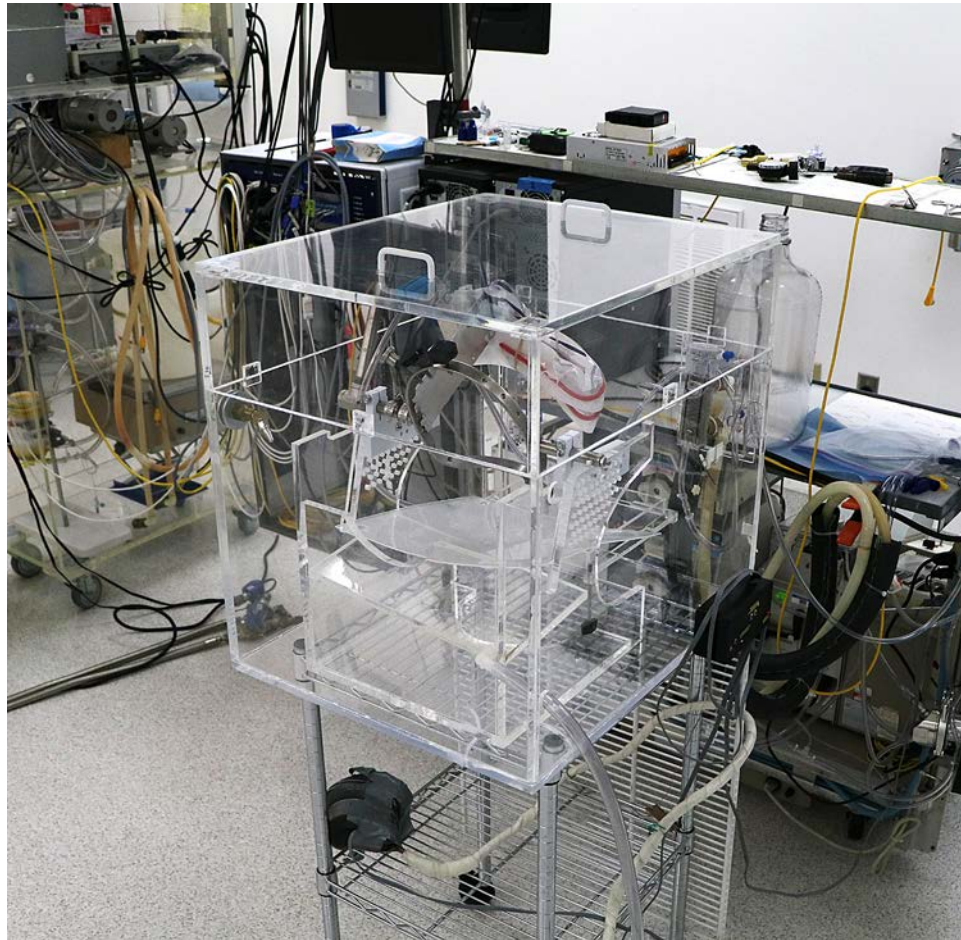

*Figure 18-3. Neuro Perfusion Enclosure*

## **Cryoprotective Circuit Design**

The cryoprotective perfusion circuit should ideally be able to perform three objectives in this sequence: blood washout, cryoprotective perfusion, and cooling.

### *Washout*

In cases where blood washout must be performed in Alcor's operating room (most local cases) it is desirable to separate this part of the procedures from the actual cryoprotective perfusion to minimize "contamination" of the circuit

with formed elements in the blood, inflammatory products, and other undesirable debris. To achieve this objective, the circuit needs to be designed to allow blood washout without using the cryoprotective circuit. This can be achieved by including separate inlet and discard lines for the washout that will leave the closed circuit cryoprotective perfusion part of the circuit “clean”. The procedure can be done as in conventional remote blood washout. In cases where the patient arrives at fairly high temperatures, however, recirculation with the washout solution might be desirable before exposure to the cryoprotective agent. For this reason, the washout part of the vitrification circuit should be able to be run closed circuit without contaminating the cryoprotective circuit.

### *Cryoprotective Perfusion*

Basic cryobiology knowledge dictates that cryoprotective agents be gradually introduced to prevent large osmotic gradients that can damage cells. This is achieved at Alcor by starting cryoprotective perfusion with a “base perfusate” (aka carrier solution, aka vehicle solution) that contains no cryoprotectant ingredients. The perfusate enters the patient through the aorta or carotid arteries, and then venous effluent from the patient is carried to a recirculating reservoir, also called mixing reservoir. Perfusate is mechanically stirred in the mixing reservoir and then recirculated back to the patient. A cryoprotectant solution concentrate is added to the mixing reservoir at a controlled rate to slowly increase the concentration of cryoprotectants in the solution being pumped back to the patient. This creates what’s called a cryoprotectant “ramp.” The ramp isn’t a physical object. The ramp is the planned profile of increasing arterial cryoprotectant concentration as a function of time, which when graphed looks like a ramp because the initial stage is usually linear.

A diagram of the cryoprotectant circuit is shown in Figure 18-4.

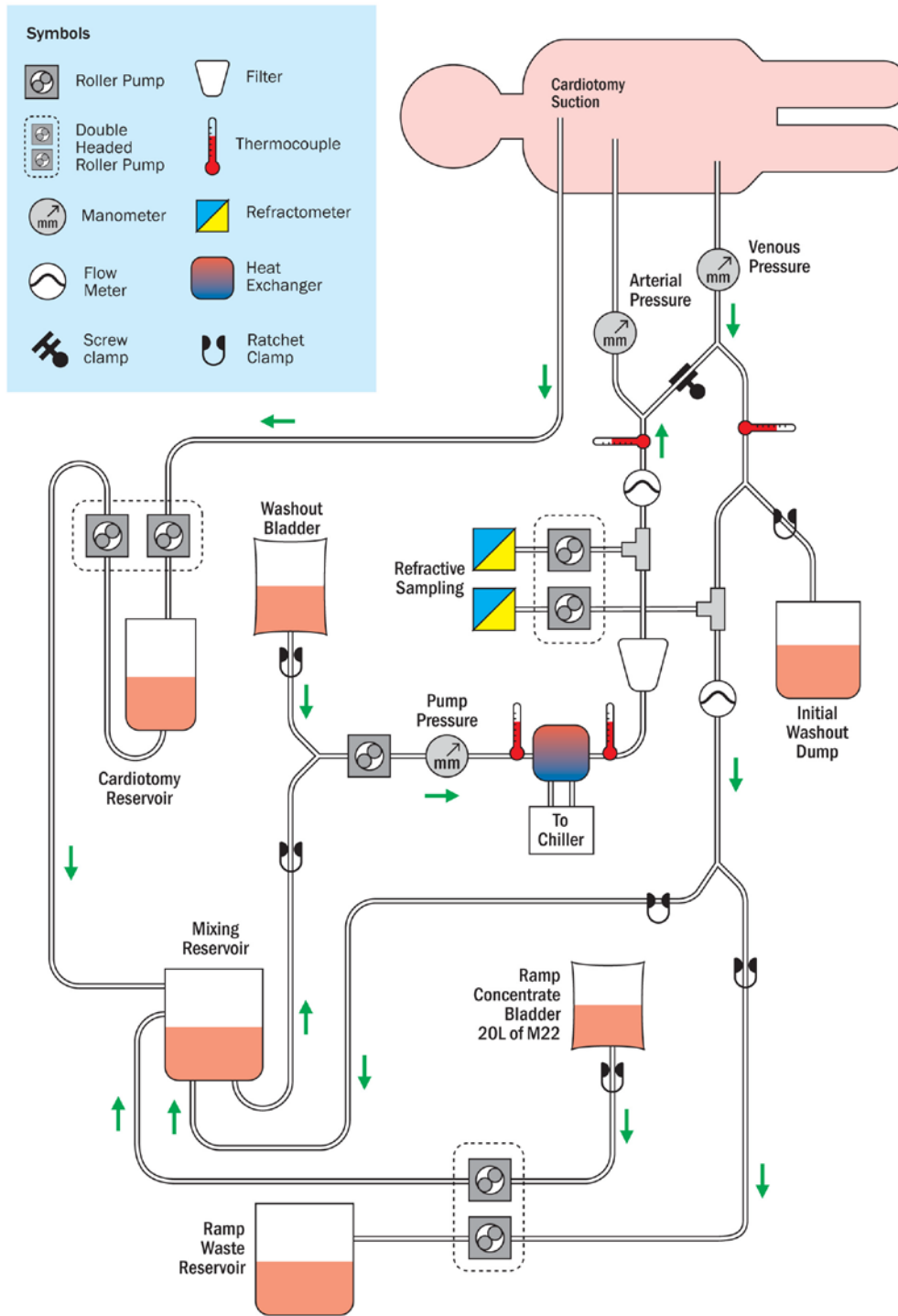

Figure 18-4. Recirculating cryoprotective perfusion circuit used at Alcor. The cannulation points are the thoracic aorta for the arterial line, and right atrium of the heart for the venous line.

As cryoprotectants replace water inside cells, the venous effluent leaving the patient and returning to the mixing reservoir has a slightly lower concentration of cryoprotectants than the solution going into the patient. This arterio-venous concentration deficit is further increased if the arterial concentration is increasing with time. However the arterio-venous concentration deficit will remain, even if the arterial concentration is held constant, until the concentration of cryoprotectant inside the patient equilibrates with the perfused arterial concentration. This concentration deficit is compensated by cryoprotectant concentrate solution being continuously added to the mixing reservoir so as to maintain the desired arterial concentration at every stage of the perfusion. Perfusate is discarded from the venous side of the circuit as necessary to maintain a constant reservoir level as concentrate solution is added.

The perfusion circuit design described above is called a “closed circuit” system. Closed circuit perfusion is the state-of-the-art perfusion method used in cardiopulmonary bypass for heart surgeries (without cryoprotectant), organ cryopreservation research, and that is also preferred for cryonics. Its principal advantage is that the cryoprotectant concentration can be controlled continuously over as long a time as is necessary to achieve effective cryoprotection of tissues without excessive consumption of perfusate. It also minimizes use of expensive cryoprotectant solutions and greatly reduces perfusate waste.

An alternative to a closed circuit with a mixing reservoir is to introduce the cryoprotective agents in a series of increased concentrations, without recirculating the perfusate. This is commonly known as an “open circuit” system. This simpler method is currently used by Alcor for a procedure called field cryoprotection. How such a method compares to closed circuit perfusion depends on the number of steps (perfusates with different concentration) at which the cryoprotective agent is introduced. An advantage of introducing the agent in such a manner is that residual blood cells and products of cell lysis will not be recirculated. Another advantage is that operation of the perfusion circuit will be easier because a number of components, such as the mixing reservoir, can be eliminated from the circuit. A major disadvantage is that

such open circuit perfusion will require much larger amounts of the perfusate, which is not desirable in light of the costs of agents like B2C and M22.

Another disadvantage is the frequent changing of perfusate bags that such a system requires, increasing the probability of errors such as introducing air emboli into the system. It is most practical for neuropatients (or cryoprotection of only the head of whole body patients) at locations too far away to transport at hypothermic temperatures to Alcor to benefit from a more controlled perfusion in Alcor's operating room.

### *Minimizing Perfusate Loss*

In whole body cryopreservation another component of the vitrification circuit is the "cardiotomy sucker" and reservoir that is used to return perfusate to the circuit that is leaks into the thoracic cavity during perfusion as a result of surgical access to cannulate the heart and surgical wounds. It's generally preferable to discard suctioned perfusate, but it may be returned to the circuit if the loss is large.

### *Refractive Index Measurements*

In a closed circuit system, the concentration of cryoprotectant is measured by instruments that measure the refractive index of perfusate. The refractive index may then converted to cryoprotectant concentration by a calibration scale that is specific to the cryoprotectant solution being used. Alcor practices the convention of recording refractive index readings in Brix (a scale widely used in the food industry), and then managing the perfusion based on reaching a target Brix value that corresponds to the desired target cryoprotectant concentration.

Inline refractometry requires modification of the circuit, depending how the refractive index of the perfusate is monitored during cryoprotective perfusion. The current state of the art is to complement taking intermittent refractive readings from the arterial and venous side with inline refractometry to monitor trends over time. Important decisions (such as ending cryoprotective perfusion) are usually made by consulting the readings of a handheld or benchtop refractometer.



Inline refractometry affects cryoprotectant perfusion circuit design because a choice needs to be made of whether to equip the circuit with the ability to control the temperature of the perfusate to produce reliable refractometry readings. Because the temperature of the perfusate varies as cryoprotection perfusion progresses, and the refractive index of solutions varies with temperature, and the magnitude of this variation increases with concentration, it is desirable to obtain temperature adjustment of inline refractometry readings. Basic inline refractometers have internal temperature compensation circuits that provide temperature correction that is only exactly correct at one particular concentration. The most expensive industry inline refractometers have user-programmable temperature compensation coefficient tables that can be configured for accurate temperature compensation at all concentrations across a temperature range. An alternative to temperature compensation is to install inline refractometers into bypass lines in which small quantities of perfusate are sampled and temperature conditioned before passage through the refractometers. However this makes the perfusion circuit substantially more complicated. Imperfect temperature compensation is the primary reason why offline precision refractometer measurement of perfusate samples is the gold standard for determining if concentration targets have been reached.

The circuit contains a separate washout “circuit” and hookup to reduce contamination of the circuit with blood.

The circuit includes separate, optional arterial and venous lines that direct a small portion of the perfusate to a warming bath prior to entering the inline refractometers. The perfusate can be discarded in the waste reservoir.

The last optional part of the circuit is the cardiomy sucker and reservoir. Returning cardiomy suction to the circuit is undesirable, but may be necessary to prevent depletion of circuit volume if suction drainage is faster than the rate of cryoprotectant concentrate addition.

## **Oxygenator**

Though most extracorporeal heat exchangers come with an oxygenator, oxygenation is presently only considered of value during higher temperature

perfusion, such as during blood washout and cooling to toward 0 degrees C. Although future research may show otherwise, oxygenation is presently considered not to be indicated during cryoprotectant perfusion.

## **Stir Plate and Stir Bar**

The concentrate is added to the base perfusate in the mixing reservoir and needs to be mixed before delivering it to the patient at the arterial side. The most important considerations for the stir plate and mixing reservoir are: the set-up should be physically stable (the stir bar should stay in the middle and not spin out of place); mixing needs to be vigorous, instantaneous, and homogeneous; and dead space needs to be reduced.

In case an “unconventional” choice for a mixing reservoir is made (for example, glass or a plastic that has not been used before) it is important to validate the stir plate / mixing reservoir setup by running experiments with a suitable aqueous solution for issues like mixing efficiency, homogeneity, stability of the stir bar during prolonged use and related issues.

## **Eliminating Foam and Air Bubble Formation**

Because the concentrate has a higher specific gravity than the base perfusate, vigorous mixing is required to prevent the concentrate from sinking to the bottom of the mixing reservoir. But the requirement of vigorous and instantaneous mixing introduces different risks such as foam and air bubble formation. Air bubbles can be introduced to the perfusate through the stirring-induced air vortex. As the viscosity of the solution increases, saturated air bubbles can induce foam formation. This phenomenon is further aggravated by some of the polymers in the latest vitrification solutions (as evidenced by serious foam formation during the final stages of the cryoprotection of patient A-1049 in 2006). To some degree these problems can be reduced by maintaining a high level of perfusate in the mixing reservoir and limiting the RPM (rotations per minute) to the minimum required to produce adequate and homogenous mixing of the perfusate. A specific solution to (micro) bubble formation is to equip the reservoir with a “floating lid” to prevent generation

of an air vortex. This lid can be made of similar (or related) material and should allow the addition of weight or a (sterile) fluid to prevent wobbling and tipping of the lid. Foam formation can be eliminated by coating the bottom of the lid with defoamers / antifoamers.

Another solution to the problem is to include a reservoir between the mixing reservoir and the arterial pump that has an antifoaming coating. Although such a coating has been implemented with success in the past in cryonics, adding another reservoir (if a reservoir is added to the venous side as well) may complicate the circuit even further and might produce more risks than benefits. The combination of prudent stirring speed, a floating lid and an effective arterial filter should be able to reduce most of the concerns. Some basic experiments to determine the degree to which the circuit needs to be modified to eliminate (micro)bubbles and foam.

## **Heat Exchanger**

A heat exchanger is part of the vitrification circuit to do washout and cryoprotective perfusion at hypothermic temperatures and to cool the perfusate to high subzero temperatures during the final stages of cryoprotectant perfusion. The ideal heat exchanger for a vitrification circuit has excellent heat conductivity, is chemically resistant, can tolerate thermal stress during operation, and is made to operate under subzero temperatures. Although heat exchangers usually come combined with an oxygenator, there are separate medical and industrial heat exchangers on the market that are more suitable

## **Arterial filter**

A 40 micron filter is included in the vitrification circuit to remove air bubbles and particulate matter. To be on the safe side a bypass line can be added to the filter to deal with a dysfunctional (clogged) filter. The filter can be bypassed by simply clamping the line inferior to the filter. Cryoprotective perfusion can be continued without the filter or a new filter can be cut into the line (when it does not have flow) and perfusion through this filter can be continued.

A 0.2 pre-bypass filter can be added to the circuit to filter the cryoprotectant concentrate prior to entering the mixing reservoir. One advantage of this setup is that particulate matter (such as sedimentation or plastic particles) that have accumulated during storage of the perfusate can be removed prior to perfusing the patient. Because the diameter of red blood cells is larger than the pores of a 0.2 micron filter, such a filter should never be placed in the recirculating part of the vitrification circuit, but between the cryoprotectant addition pump and the mixing reservoir.

There are at least two problems with adding a pre-bypass filter to the circuit: 1) This will introduce differences in flow rate between the addition and discard line of the circuit if the same pump is used); and 2) The pre-bypass filter can get clogged as a result of a high particulate matter and/or the perfusate itself. A pre-bypass filter in the refractometry line, to remove particles before measurements, could also be beneficial but in light of residual blood in the venous line a 40 micron filter is advisable in this case as well.

## **Sample Ports**

The arterial and venous lines should be equipped with sample ports to take blood and perfusate samples during washout and cryoprotective perfusion. Although professional perfusionists prefer not to sample directly from the arterial and venous lines, the “reservoir and gang of stopcocks-method” they utilize is too complicated for the average vitrification circuit operator and may actually be riskier as a result. There should be at least three sample ports in the circuit: 1) arterial line, 2) venous line proximal to the patient for sampling during washout, and 3) venous line distal to the patient for sampling of the perfusate during recirculation. One other possibility is a sample port between the cryoprotectant addition pump and the mixing reservoir to sample the solution for quality control measures. A sample port in the reservoir is also a good idea to assess the quality of mixing. The sample ports can be created inserting a connector with a stopcock and luer-lock through which samples can be taken by screwing in a syringe that can be filled and closed by turning the stopcock.

## **Temperature**

Temperature is measured at the arterial and venous site and can be measured inline using a thermocouple which can be either hooked up to a temperature logger or software. Temperature can be further measured in the patient at locations such as in the nose (nasopharyngeal) and the brain. If a warming bath will be added to the vitrification circuit, temperature measurements need to be taken there as well.

## **Refractometry**

Refractometry, as far as it concerns circuit design considerations, has been discussed in some detail above. Refractive index measures should be taken continuously inline and intermittently from the sample port.

There are a lot of handheld and benchtop refractometers on the market. In the past cryonics organizations have used inexpensive handheld refractometers. Both major cryonics organizations have now abandoned such refractometers in favor of more expensive (used) benchtop and handheld refractometers. These refractometers are robust, reliable and more suited for cryonics purposes, and some of them feature integrated data collection and laptop connections.

## **Pressure**

A manometer and transducer can be used to measure pressure in the circuit to allow for manual adjustments of flow rate. The current system at Alcor uses automated pressure data collection which is used by the software to control pump speed.

One limitation of measuring pressure only in the circuit is that it does not take into account the pressure changes (drops) that are produced by the cannulae. One solution to this problem is use of an arterial perfusion cannula with integral pressure monitoring line.

## **Pumps**

Any kind of (medical) roller pump that can generate sufficient flow for cryoprotective perfusion can be used. If the perfusion circuit is equipped with software to monitor and control perfusion, pumps that allow speed control by external signal are necessary.

One issue that should be given some thought during development of a perfusion circuit is whether pulsatile flow is desired. There is now a wealth of literature on the potential benefits of generating pulsatile flow during cardiopulmonary bypass and a review of such literature might be warranted. The benefit of using pulsatile flow cryoprotective perfusion remains a topic of discussion. Older case reports of Alcor cases document the rational and use of this technology.

## **Waste Reservoirs**

Unlike the mixing reservoir, the choice for waste reservoirs does not require much research. Any type of water jug or plastic reservoir should suffice. It is recommended, however, to have a separate washout and cryoprotective perfusion waste reservoir in case there is a scenario where perfusate from the waste reservoir needs to be re-introduced to the circuit. In such an (unfortunate) scenario it is desirable that the perfusate is not mixed with the blood and toxic elements that were initially washed out.

## **Cryoprotective Perfusion Cooling Options**

During washout and the first stages of cryoprotective perfusion the perfusate can be cooled by running it through a heat exchanger that is supplied by ice water. Cooling can be enhanced by keeping the perfusate cold prior and during cryoprotective perfusion. Cooling can be further enhanced by placing the vitrification set-up (or most of it) in a refrigerated area. When the temperature needs to be dropped to subzero temperatures there are basically three options: 1) Adding salt or antifreeze to an ice water bath that supplies coolant to a heat exchanger. 2) Using an industrial chiller that uses mechanical

refrigeration to cool an antifreeze coolant solution (such as ethylene glycol solution) as a circulating fluid for the heat exchanger. 3) A chiller that uses liquid nitrogen (LN2) to cool the coolant. Experiments started at Suspended Animation by Mathew Sullivan and later adapted by Alcor culminated in the development of a custom-built LN2-driven chiller which is still in use today to cool the perfusate lines and the patient enclosure. See Figure 18-5.



Figure 18-5. Alcor Liquid Nitrogen Chiller

## Whole Body Cryoprotective Perfusion Circuit Operation

### *Preparation for Perfusion*

Each new whole body case requires a new sterile tubing pack. The only components in the circuit that are re-used are the pumps, the mixing reservoir, the refractometers, and the electronics to collect data during cryoprotective perfusion. Alcor should have at least 2 sterilized tubing packs available for

whole body cases at any time. After a case, OR supplies should be re-stocked and a new whole body circuit should be installed, strung, and checked (but not run) to restore cryoprotective perfusion capabilities as soon as possible. An experienced person should allow for at least 4 hours (including ½ to 1 hour for connecting the electronics) to install, string and check a new perfusion circuit.

The first step in preparing the circuit for cryoprotectant perfusion is to prime the circuit with the washout solution and base perfusate: B1. The washout solution comes in 20 liter bags and one bag is generally sufficient to wash out the blood of the patient. If the patient's blood has already been washed out during remote stabilization procedures, a modest initial washout is still recommended. This will also ensure that no expensive cryoprotective perfusate is wasted in a futile cryoprotective perfusion attempt if it is determined that perfusion of the patient is not feasible. The B1 washout perfusate should be sterile but should be checked for mold growth because this solution is a fertile growth medium for micro-organisms when sterility has been breached.

Before the circuit is primed with B1 all the connections should be checked to ensure that there are no leaks in the circuit or components that have not been properly secured. Priming of the circuit is initiated by filling the Mixing Reservoir with B1 up to 10 liters, circulating it through the complete circuit, excluding the Cardiotomy Reservoir line and the Waste Reservoir lines. During priming the lines to the Waste Reservoirs and the Cardiotomy Reservoir line are clamped. During priming air bubbles are eliminated from the circuit, the various components are checked and the target temperature of the perfusate is lowered to approximate 0 degrees Celsius (but not lower!).

### *Blood washout*

When the system is primed and maintained at the right temperature, washout of the patient is initiated when the circuit is connected to the patient's cannulae and the surgeon indicates that the line to the patient can be unclamped. During washout only a portion of the complete circuit is used, and the venous effluent is dumped in a separate waste reservoir. If the initial blood washout is used to take a venous sample of the patient, it is important to take this sample as soon as possible to ensure that the blood sample will not be



diluted with the washout solution. Initial washout of the patient should be continued until the venous effluent of the patient shows a consistent clear color or the perfusate has been exhausted. If no acceptable washout is possible due a severely compromised vascular bed and/or edema, the team leader and perfusionst can decide to decide to terminate any attempt at cryoprotective perfusion of the patient.

### *Cryoprotective Perfusion*

Cryoprotective perfusion of the patient requires two different solutions. A carrier solution (base perfusate) that will be the starting perfusate in the Mixing Reservoir, and the M22 concentrate for whole body patient in a carrier solution that will be gradually added to the Mixing Reservoir. It is important to remember that the M22 concentrate also includes the carrier solution to avoid diluting the carrier solution ingredients in the mixing reservoir when more concentrate is added.

The M22 concentrate for whole body preservation and M22 concentrate for neuro preservation are not the same. M22 concentrate for whole body patients has an additional component to mitigate edema during perfusion. It is therefore mandatory to verify if the right solution has been chosen for the patient. The concentrate comes in a higher concentration than is necessary to vitrify (such as 1.2 or 1.25 times the published nominal full concentration M22) to ensure that the target concentration in the patient will be achieved within a reasonable period of time.

To initiate cryoprotectant perfusion the mixing reservoir should contain at least 15-20 liters of B1 (the carrier solution). During perfusion the M22 concentrate is gradually added to the reservoir and rapidly mixed through the use of a large magnetic stirring bar. The proper position and functioning of the stirring bar should be monitored throughout perfusion to ensure that proper mixing of the carrier solution with the concentrate is taking place. During perfusion the level in the mixing reservoir should be monitored to avoid the reservoir running dry and introducing air into the patient. The perfusate level in the Mixing Reservoir should not be allowed to drop below 7 liters.

Watching and documenting the level of the mixing reservoir is one of the tasks of a scribe in the OR. If the level of the mixing reservoir starts dropping

to unacceptable levels, the perfusionist can increase the pump speed of the pump that supplies the concentrate to the reservoir and clamp off the discard line to return more perfusate to the mixing reservoir. If the mixing reservoir is observed to be in real danger of running dry the pumps should be stopped and perfusion halted until the perfusionist has restored enough volume to the mixing reservoir to safely resume cryoprotective perfusion.

M22 concentrate is gradually introduced to the mixing reservoir by a dual head pump that also controls the discard line. After mixing in the mixing reservoir the perfusate runs through the heat exchanger and filter to the arterial side of the patient. After the perfusate is exchanged for water in the patient the effluent returns on the venous side where most of the perfusate is returned to the mixing reservoir and a portion is discarded.

During cryoprotective perfusion the following parameters are being monitored: system pressure, arterial perfusion line pressure, arterial temperature and the refractive index. The refractive index is being monitored in-line and displayed on the computer screen and manual refractometry samples are taken. As a general rule, the inline refractometers are used to monitor trends and the manual samples are used to make important decisions such as decreasing the temperature for the second half of perfusion and terminating cryoprotective perfusion.

### *Subzero Cryoprotective Perfusion*

When 50% of target arterial concentration is reached after 90 minutes, as evidenced by manual refractometry readings, the ramp is paused to hold the arterial concentration steady. Concentrate is only added as necessary to hold the arterial concentration at a plateau of 50% of target while the venous concentration catches up. During this time, the chiller coolant temperature is dropped as to necessary to decrease the perfusate temperature in the arterial line from +3 degrees Celsius to -3 degrees Celsius. After holding the 50% plateau for a minimum of 15 minutes, and only after an arterial temperature of -3 degrees Celsius is attained, concentrate addition resumes to raise the arterial concentration to 105% of target concentration as quickly as possible without overshooting. The target concentration is also called CNV or “concentration needed to vitrify” (currently the published nominal concentration of M22

vitrification solution). When the arterial concentration of 105% CNV has been achieved as measured by manual refractometry, concentrate continues to be pumped at whatever rate is necessary to maintain this arterial concentration plateau until the venous concentration rises to 100% CNV. The plateau should be maintained for a minimum of 60 minutes and a maximum ideally not exceeding 90 minutes.

In some cases, Alcor will be able to initiate cryoprotective perfusion but will progressively encounter poor perfusion and increasing edema. If these problems cannot be overcome through surgical adjustments, Alcor can decide to terminate perfusion. Cryoprotective perfusion is not an all-or-nothing operation and in some circumstances Alcor may only be able to reach lower target concentrations.

### *Pressure*

Recommended arterial perfusion pressure for whole body patients is between 80 mmHg and 100 mmHg and should not exceed 120 mmHg. This is especially important in the case of patients with ischemic exposure or prolonged cold transport times. Perfusion pressures should be carefully monitored. If the perfusion pressure is not controlled by software it is important to be aware of the fact that pressures will respond to temperature and CPA concentration and tend to rise quickly during the final stages of perfusion when the temperature is dropped below zero and the viscosity of the solution increases. Ideally arterial line pressures should be corrected for pressure loss in cannula, if known, to achieve the desired target pressures intra-arterially.

After cryoprotective perfusion is completed, the patient may be removed from the enclosure for deep cooling or may remain in the enclosure for initial stages of deep cooling, depending of the design of the enclosure.

### *Negative Pressure for Venous Return*

As is customary with clinical cardiopulmonary bypass, Alcor does not use a pump to return venous blood from the patient to the mixing reservoir. This means that venous pressure will rise inside a patient's veins to whatever pressure is necessary to overcome flow resistance through the cannula and

tubing between the right heart and mixing reservoir. During normal blood circulation, veins have a very low pressure inside them. If pressure inside a patient's right heart and vena cava is allowed to rise to more than just a few mmHg, systemic edema and filling of the lungs with perfusate is likely to result. The most effective blood washout and cryoprotective perfusion, with least edema or pulmonary leakage, will result from maintaining venous pressure as close to 0 (zero) mmHg as possible.

Venous pressure at the venous cannulation point can be minimized by placing the venous return reservoir (mixing reservoir) near the floor, several feet below the patient. This creates a negative pressure, or suction, to offset the positive pressure that would otherwise be necessary to move perfusate through the venous cannula and venous return lines. Ideally the reservoir should be on a table of adjustable height (e.g. "Lab Jack"). The reservoir height should be adjusted until the venous cannula is observed to "chatter" (alternately suck closed and then open), and then slightly raised. This ensures that the venous pressure inside the right atrium is being maintained at near zero pressure, which is nominal. The reservoir level necessary to minimize venous pressure should be checked and adjusted throughout the perfusion. If "chattering" cannot be achieved even with a maximum height difference between the patient and reservoir, larger venous cannula, wider tubing, or otherwise reduced flow constriction in the venous lines might be indicated.

Note that for suction to be effective, the venous lines between the patient and reservoir must be primed full of fluid. Air should not be allowed to enter and "deprime" the venous lines. If air enters the venous return lines, the lines must be reprimed immediately to avoid buildup of dangerous venous pressure inside the patient. Priming is easier if sufficient slack exists in the venous lines for an "S" to be made by the perfusionist to "walk" air through the lines to the reservoir.

## **Neuro Cryoprotective Circuit Operation**

Whether there is a distinction between a whole body perfusion circuit and neuropatient perfusion circuit depends on surgical protocol and patient enclosure. In neuropreservation protocols in which the cephalon (head) is

removed only after cryoprotection of the upper part of the body, the environment and conduct of perfusion is identical to whole body cryoprotection with the exception of clamping the descending aorta (and extremities) to direct as much of the perfusate as possible to the head. In such protocols, when the target concentration of the cryoprotectant has been reached, the cephalon is surgically removed (without warming the tissue) and placed in a cooling box for rapid deep cooling. This method was used by Alcor for cryoprotection of neuropatients during the 20th century.

Current Alcor protocol for neuropreservation is to separate the head from the rest of the body prior to starting cryoprotective perfusion. The cephalon is secured in a cephalic enclosure and the carotid vessels are cannulated. Venous perfusate can be returned from the jugular veins, or can be drained into a tray and returned to the recirculating reservoir, which is the current procedure. A major advantage of the isolated cephalon perfusion method compared to older techniques described above (or contemporary whole body perfusion) is that allowing severed jugular veins to freely drain reduces venous pressure inside the brain, thereby increasing perfusion flow rate and decreasing the time necessary at the peak arterial cryoprotectant concentration plateau for the target concentration in the venous effluent to be reached. Lower venous pressures are also expected to reduce the severity of cerebral edema that sometimes occurs in patients who suffered long periods of cerebral ischemia before the start of cryoprotectant perfusion.

The circuit that is used for perfusion of the cryoprotectant solution basically reflects the same design as whole body circuits. A roller pump withdraws the CPA concentrate from a reservoir and feeds this into the recirculating reservoir where the CPA is mixed with the carrier solution. A second pump forces the perfusate through a 40 micron filter and heat exchanger into the patient.

Cooling of the perfusate below zero degrees Celsius can be achieved by using a heat exchanger supplied by coolant fluid from a sub-zero chiller. Alcor's current setup uses an LN<sub>2</sub>-driven chiller for both perfusate and neuro enclosure temperature control.

## **Computer Control and Data Collection**

There are three basic possibilities for control and data collection during cryoprotective perfusion:

- Manual data collection and manual cryoprotection control
- Automated data collection and manual cryoprotection control
- Automated data collection and automated cryoprotection control

In theory, it would be possible to have automated perfusion control and manual data collection but, as a rule, a general technology to control perfusion requires automated data collection to do its job.

Since its inception Alcor has moved from mostly manual cryoprotection control and manual data collection to manual control of perfusion and automated data collection. More recently, Alcor has developed a system that also conducts perfusion.

The following is a list of potential characteristics of an automated perfusion and cooling system.

- Control of flow rate according to arterial pressure.
- Monitor and display temperatures, and control the chiller coolant temperature based on arterial temperature.
- Monitor and display cryoprotectant concentration (refractive index).
- Control ramp by separate volumetric addition of CPA concentrate and base perfusate. Separate addition of concentrate and base will avoid situations where making up table losses results in too-rapid increases in CPA concentration.
- Control mixing reservoir level.
- Monitor volume and concentration of ramp waste reservoir.
- Bubble and level alarms

- Dissolved oxygen and ion selective electrodes.
- Suspended solids meter (for quantifying emboli)

The more complex and “autonomous” such a software-controlled system is, the more important it is to include a failure mode to (temporarily) stop software control revert to manual control of pumps and pressure monitoring.

## **Surgery**

Surgical procedures associated with cryoprotection procedures include:

- Surgery to obtain access to the patient’s vascular system to wash out the blood.
- Surgery to obtain access to the vascular system to perfuse the patient with a cryoprotectant.
- Surgery to create small “burr holes” in the cranium to visually validate cryoprotectant perfusion and observe changes in brain volume.
- Surgery to isolate the cephalon from the body

### *Surgery Preceding Whole-Body Cryoprotection*

In whole-body cases, the surgeon performs a median sternotomy and places an arterial cannula in the aorta and a venous cannula in the right atrium for venous return.

Alternatively, it’s theoretically possible to conduct a whole body cryoprotective perfusion using femoral cannulae that are sometimes used for field blood washout of remote cases prior to transport to Alcor. However femoral cryoprotectant perfusion is difficult because femoral vessel and cannulae diameters are too small to deliver the necessary flow rates without very high back pressures. Systemic venous pressures would also be undesirably high. (Limited open-circuit femoral whole body cryoprotection was done once in the field for Alcor patient A-2158, with venous drainage facilitated by the cephalon being already severed for faster transport to Alcor

ahead of the rest of the body due delays obtaining an interstate transit permit for human remains.)

### *Surgery Preceding Neuro Cryoprotection*

Although it's theoretically possible to use the same surgical technique as for whole body patients, this would not only be very time inefficient but also substantially increase the cost of the cryoprotectant. For this reason, in surgery for neuropreservation patients cannulation techniques are used to ensure that only the head and brain will be perfused. Several different approaches are known in cryonics.

Option 1 (used only historically by Alcor). The surgeon performs a median sternotomy and places an arterial cannula in the aortic arch and a venous cannula in the superior vena for venous return. Systemic and upper body perfusion can be prevented by clamping the descending aorta and placing tourniquets on the arms. A more sophisticated approach to using tourniquets would be to ligate the subclavian arteries distal to the vertebral arteries. Venous return from the extremities can be prevented by ligating the left and right innominate veins distal to the left and right internal jugular veins. See Figure 18-6.

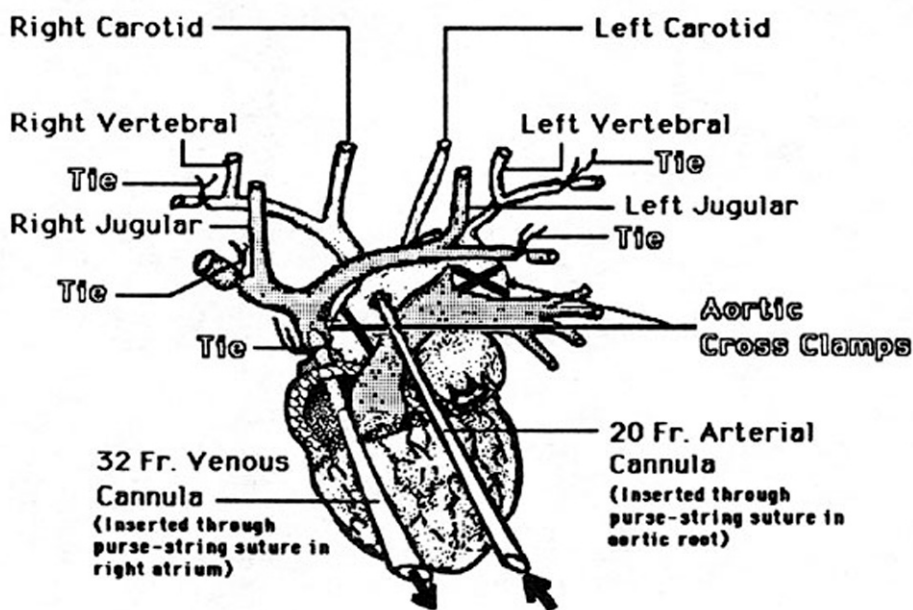



Figure 18-6. Cannulation of vessels near the heart.

After completion of perfusion, a circumferential skin incision is made at the base of the neck extending anteriorly and posteriorly to just below the margins of the clavicle. The skin is dissected from the underlying connective tissue up the level of the 5th cervical vertebra to form skin flaps. The muscles of the neck are cut with a #10 scalpel down to the junction of the 5th and 6th cervical vertebrae. The cephalon is removed from the body using a Satterlee or Gigli saw by cutting between the 5th and 6th cervical vertebrae.

Option 2. An alternative approach that has been practiced by the Cryonics Institute is to perfuse all the vessels supplying blood to the brain by cannulating just proximal to the bifurcation that perfuses both the vertebral and carotid arteries, ligating the subclavian artery distal to the vertebral on the right side of the body, and individually cannulating the vertebral and carotid arteries on the left side of the body. See Figure 18-7.

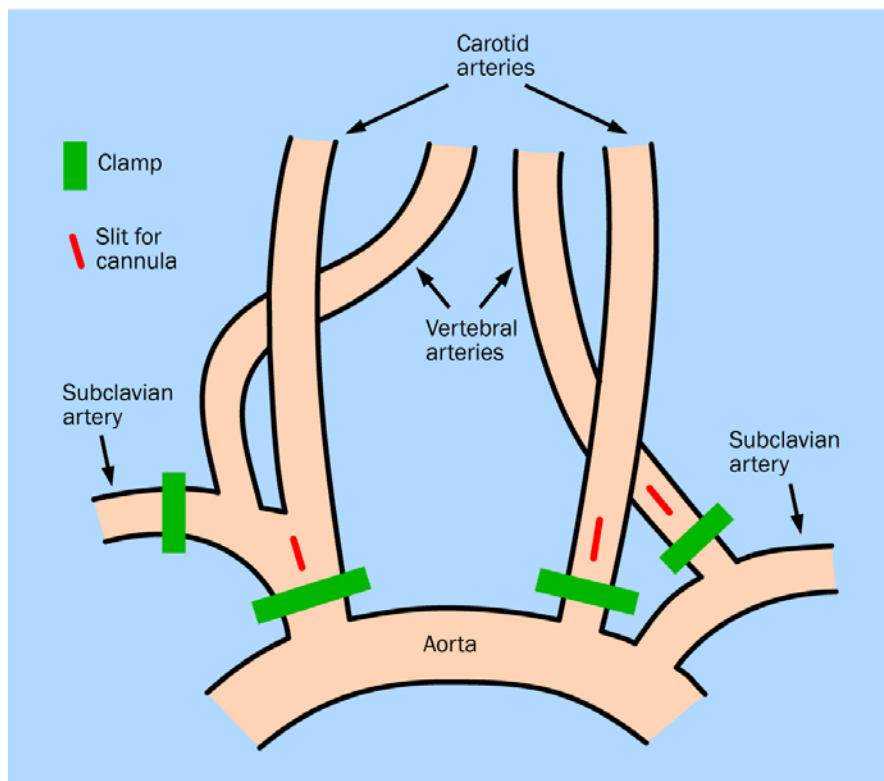

Figure 7. Surgical technique used at the Cryonics Institute.

Option 3. The alternative that is currently practiced at Alcor is to cannulate the carotid arteries, remove the cephalon (cephalic isolation), and perfuse the head through the carotid cannulae while the head is held in a specially designed temperature-controlled enclosure. One drawback of this technique is that in some patients the internal carotids (that supply blood to the brain) branch from external carotids (supplying blood to the scalp and face) below the level of the clavicle in the chest, which can reduce or eliminate perfusion of facial tissues. Whether both the carotid and the vertebral arteries need to be cannulated depends on whether the patient has an intact Circle of Willis. If there is reason to suspect that the patient does not have an intact Circle of Willis (i.e. no effluent observed from vertebrales during carotid perfusion), cannulating all four major cerebral vessels is required. Otherwise the vertebral arteries are clamped after observing effluent from them so that arterial pressure inside the Circle of Willis isn't reduced by open vertebrales.

### *Burr Holes*

Burr holes are drilled in the skull by a neurosurgical tool called a perforator to monitor when the brain shrinks (normal response) or swells in response to cryoprotectant perfusion. After shaving the head two 3-5 cm scalp incisions are made 2 cm from the midline on each parietal lobe using a scalpel blade. The scalp is retracted and a bone scraper is used to remove tissue from the scalp. Two burr holes are made using a surgical device known as a perforator, while squirting sterile saline to cool the perforator and tissue. A rongeur can be used to enlarge the holes, if necessary. The dura mater is opened using a dura hook (to retract the dura away from the brain) and iris scissors or a scalpel blade. Thermocouples and a "crackphone" (acoustic microphone to monitor fracturing during cryogenic cooldown) can be placed between the skull and the dura. After cryoprotectant perfusion, the burr holes are filled with bone wax and the incisions are closed with staples.

## **Monitoring Cryoprotective Perfusion**

Whereas patient monitoring in stabilization procedures (like blood sampling) is mostly used to improve and guide future cases, during cryoprotective perfusion monitoring generates data to actually conduct procedures. For example, arterial pressure readings are used to change pump speed to maintain a pressure target. Temperature readings are used to determine the start of cryoprotection. Refractive index measurements determine when it is time to accelerate the ramp and terminate perfusion. If the patient suffered significant ischemia prior to perfusion then monitoring weight gain, local edema, and the brain through the burr holes provide information on whether to continue or stop cryoprotection. Without monitoring for cerebral edema to determine if perfusion must be stopped, a brain could herniate through the foramen magnum during cryoprotectant perfusion.

Alcor protocol dictates that in case of isolated head perfusion the cephalon should be weighed prior and after completion of cryoprotective perfusion to determine the degree of dehydration or edema (and even infer the degree of ischemia). For whole-body patients the patient enclosure can be modified to include scales to weigh the patient prior and after cryoprotection as well (for example, during cryoprotective perfusion of Alcor patient A-1108 a bed scale was used to collect data on weight changes and the amount of weight gain was reported in the write-up). Considering the tendency of whole body patients to gain weight during cryoprotectant perfusion in cases of (extensive) ischemic exposure, documenting weight gain is important for good case reporting and meta-analysis.

Samples of the venous effluent can provide more information than just the refractive index. Manual and in-line measurements of electrolytes, metabolites, proteins, and dissolved oxygen can be done on perfusate during various stages of cryoprotection. As a general rule, not much is currently known about the chemical composition of the venous effluent of patients undergoing cryoprotective perfusion.

Tissue samples can be taken and subjected to real-time viability assays (LDH, K/Na etc) and/or prepared for electron microscopy. In this case of the

brain, microsamples of brain can be taken upon completion of cryoprotective perfusion to determine the metabolic and fine structure of the brain.

In 2011, Alcor started doing x-ray CT scans on neuropatients after completion of cooling to liquid nitrogen temperature. During the transport to and from the imaging center, and during the imaging process, patients remain safely immersed in liquid nitrogen in their containers. Originally intended to verify “crackphone” placement, the technology has been found to hold promise to determine regional cryoprotectant uptake and ice formation. The scans can also be used to look at the degree of brain dehydration (or lack thereof). The cephalon remains in its aluminum container under liquid nitrogen during the scan. In 2018 Alcor took delivery of its own in-house CT scanner.

This technology takes advantages of the differences between frozen, normal, and cryoprotected tissue. First, ice formation increases space between atoms because ice is less dense than liquid water. Unfrozen tissue therefore has a higher CT density than frozen tissue. Second, solutions of cryoprotectant chemicals have a higher physical density (more electrons per unit volume to scatter x-rays) than water. CT density therefore increases as cryoprotectant concentration increases. Finally, the cryoprotectant solutions used by Alcor contain dimethyl sulfoxide (DMSO), which contains the element sulfur. The higher atomic number of sulfur compared to oxygen in water makes it better at photoelectric absorption of x-rays.

The CT images allow Alcor to infer the quality of a cryopreservation on the brain and build a set of images that can be discussed in the context of other variables such as normothermic and cold ischemia, duration of patient transport, conduct of cryoprotective perfusion, etc. A sample scan is shown in Figure 18-8.

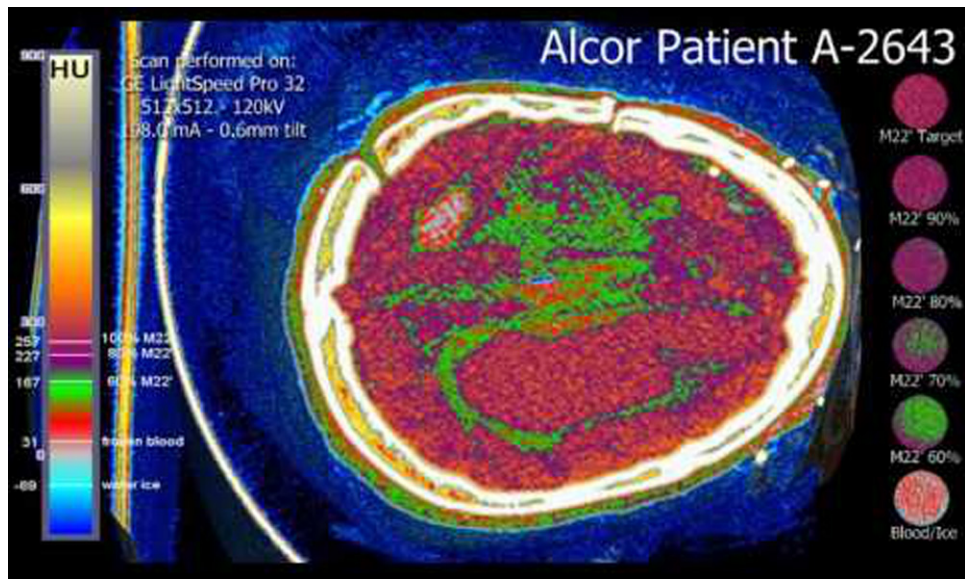

Figure 8. A CT scan of the cryopreserved brain of an Alcor patient.

## Cryoprotection of the Ischemic Patient

We define an ischemic patient as one who has sustained periods of normothermic and/or cold ischemia after cardiac arrest, long enough to affect the quality and outcomes of cryoprotection. These different outcomes can range from minor edema and blood brain barrier breakdown to a general inability to do cryoprotection at all. In such cases prolonged ischemia leaves no other option but “straight freezing” without cryoprotection, causing damage in addition to ischemia-induced ultrastructure damage.

The secondary effects of ischemia on cryoprotective perfusion can be divided into the development of edema and perfusion impairment. While these phenomena can be distinctly distinguished it should be kept in mind that (interstitial) edema can narrow the lumen of vessels and obstruct or re-direct perfusion, which in turn can lead to regional differences in cryoprotectant uptake.

One of the earliest signs that ischemia is affecting cryoprotective perfusion is a change in the permeability of blood vessels. In a rat model, blood brain barrier breakdown appeared to be complete after 1 hour of

normothermic ischemia, as evidenced by lack of dehydration of the brain and visual signs of brain edema after completion of perfusion. In a cold ischemia model, breakdown of the blood brain barrier was observed after 24 hours of cold ischemia, regardless of whether the blood was washed out or not. Weight gain after ischemia occurs in a temperature- and time-dependent manner. In fact, in laboratory experiments, whole body weight loss is often observed after completion of cryoprotective perfusion. As the duration of ischemia progresses, this weight loss is not observed and a patient can gain up to 50% in weight in cases with extensive normothermic and cold ischemia. Edema can often be observed in the face and the abdomen seems particularly susceptible to edema, especially when DMSO-based perfusates are used. While cryopreservation without ice formation may still be possible after 48 hours of bloodless cold ischemia (if blood was replaced with MHP-2 blood washout solution prior to the ischemic period), the extensive swelling associated with ischemia cannot be mitigated with any kind of cold organ preservation solution currently known.

Ischemia-induced perfusion impairment is a multi-factorial phenomenon and vascular leaking, interstitial edema, brain swelling, blood coagulation, and red blood cell aggregation combine to produce heterogeneous and incomplete perfusion of the brain. In extreme cases, most parts of the brain will freeze despite cryoprotection procedures. In cases with extensive ischemia longer perfusion times should be expected and it will take longer for venous effluent to reach the target concentration of the vitrification solution. In some cases the refractive index of the venous perfusate fails to further increase at all. In ischemic cases reaching target concentration does not necessarily mean that that all areas of the brain (or body) have received enough cryoprotectant to prevent freezing. Other phenomena that should be expected in the perfusion of the ischemic patient include extensive fluids leaking from the heart and lungs, poor venous return (particularly in whole body cases), ascites, and filling of intestines with perfusate further exacerbating abdominal swelling of whole body patients.

Pharmaceutical interventions to prevent these ischemia-induced challenges are limited. The combination of sodium citrate and heparin have allowed ice-free cryopreservation in the rat model after up to 2 hours of

normothermic ischemia but these benefits disappear if these medications are not administered within 30 minutes of circulatory arrest.

There is some preliminary evidence from the scientific literature on organ preservation and data from cryonics-associated labs that adding streptokinase to the washout solution prior to the start of cryoprotective perfusion could improve perfusion after cold ischemia. High molecular weight polymers (colloids) may be effective to retain perfusate in the vessels in cases where ischemia exposure is limited. When the ischemic period is longer than 1 hour of normothermic ischemia or 24 hours of cold ischemia, swelling will happen nonetheless.

In patients with extensive ischemia it may be especially important to limit perfusion pressures. In the rat model cryoprotection of the brain was improved when maximum arterial pressures were lowered to 80 mmHg. Other cryonics-associated labs have also observed improved outcomes from lowering perfusion pressure. Other approaches that have been tested include the use of hyper-viscous carrier solutions and aggressive ramping to target concentration.

It is currently not possible to give hard criteria for when to abandon cryoprotection in ischemic patients. This determination is also complicated by the fact that ischemic changes in the patient often start prior to pronouncement of legal death. During stabilization, interruptions in procedures, suboptimal CPS, and slow cooling can also produce some degree of ischemia. Another complicating factor is that we have little understanding of the (ultrastructural) effects of the longer perfusion times that are associated with cryoprotection of the ischemic patient.

Based on available case reports, practice, and research cryoprotection still outweighs the adverse of effects of ischemia up to 48 hours of cold (bloodless) ischemia if cryoprotection is possible. Ice-free cryopreservation of the ischemic brain is possible after at least 1 hour of normothermic ischemia, as evidenced by rat and porcine experiments.

A special subset of ischemic cases concerns cryoprotective perfusion of a patient that has sustained an ischemic or hemorrhagic stroke as the cause of death. While cryonics organizations have cryopreserved a number of patients who suffered lethal strokes, no systematic treatment has been written how to

deal with such cases. Some questions that need to be addressed include: Should cryoprotective perfusion be attempted in patients who sustained a (massive) hemorrhagic stroke? Should anti-coagulants and fibrinolytics be administered to either ischemic or hemorrhagic stroke patients? What perfusion pressures should be used in patients who have sustained a stroke? Do hyperosmolar solutions restore circulation to areas of the brain that sustained a stroke? What role can CT scans play in the perfusion of such patients? These are not questions that can be addressed in this manual but we identify these issues here as an important research and clinical topics.

## **Field Cryoprotection**

Two of the most important variables affecting the successful preservation of a patient are time and temperature. They are clearly related. If the time between pronouncement of legal death and the start of cryoprotection is minimized we can place the patient in long-term cryostasis without incurring unnecessary cold ischemic injury. Not surprisingly, it has occurred to a number of people in the cryonics field that the quality of care could be improved if we eliminate the prolonged cold ischemic time that is typically associated with remote cryonics cases (i.e. Alcor cases remote from Scottsdale, Arizona). In this section we will outline potential protocols and challenges concerning field cryoprotection.

Field cryoprotection is the replacement of blood and tissue water by solutions of cryoprotective agents (CPAs) near the location of legal death, followed by prompt cooling to dry ice ( $-79$  degrees C) or lower temperatures at the same remote location. If a temperature cold enough to achieve a solid state is attained (approximately  $-130$  degrees C), the procedure could be called field cryopreservation.

### *Rationale of Field Cryoprotection*

To understand the rationale and challenges associated with the idea of field cryoprotection it is useful to briefly describe the current procedure for remote cases.



When an Alcor member is considered terminal and close to legal death, a standby team should be deployed to the bedside of the patient. For cases outside of Arizona, in the continental United States, the team may be provided by an independent contractor such as Suspended Animation, Inc., and may include a surgeon and clinical perfusionist.

Upon pronouncement of legal death the team begins chest compressions and rapid cooling in an ice bath, and administers a series of medications to mitigate ischemia. If a qualified surgeon is part of the team, or of a cooperating mortician is considered sufficiently competent, an additional procedure is to perform a field washout in which blood is replaced by a cold (but not freezing) organ preservation solution. This procedure is described in Section 16 of this book, discussing remote blood washout.

The three most important objectives of the washout are:

- Increase the cooling rate
- Remove the blood and risk of coagulation and cold agglutination
- Protect the patient against the effects of cold ischemia by introducing an organ preservation solution.

The patient is then shipped on water ice to the cryonics facility for cryoprotective perfusion and long-term care.

Between the end of blood washout and the start of cryoprotective perfusion the patient is basically experiencing a prolonged period of cold ischemia, the duration of which is dependent on variables such as the availability of air transport to the cryonics facility. While experimental evidence at a number of cryonics-associated research labs indicates that remote blood washout is superior to leaving the blood in the patient, it should be evident that prolonged cold ischemia is not beneficial to the patient and could be completely eliminated when there is a smooth transition from stabilization to cryoprotective perfusion. For example, blood substitution with a static organ preservation solution can keep the brain viable (able to spontaneously resume function upon reperfusion with blood) for about 6 hours in the most optimistic projections.

Proposed benefits of field cryoprotection include:

- One single deployment required for both stabilization and cryoprotection
- Elimination (or minimization) of cold ischemia
- One surgical procedure required
- A reduction of total procedure time

### *Terminology, Historical Background, and Research*

In the context of this article, field cryoprotection is defined as the procedure of conducting cryoprotective perfusion at a location remote from the cryonics facility followed by transport of the patient on dry ice for further cryogenic cooldown and long term care at the cryonics facility.

Field cryoprotection is not necessarily the same thing as field vitrification, which would require cryogenic cooling on-site and shipping at around  $-130$  degrees Celsius (below the glass transition temperature of the vitrification agent) or  $-196$  degrees Celsius (liquid nitrogen temperature). While it is not impossible to ship the patient at such temperatures it would introduce a number of non-trivial technological and logistical challenges. This would also likely offset any cost reductions associated with conducting cryoprotective perfusion in the field. As will be discussed below, in field cryoprotection the patient is cooled below 0 degrees Celsius after cryoprotective perfusion but not to a temperature where the vitrification agent solidifies into a glass. For this reason the procedure discussed in this article should be named field cryoprotection (or field cryoprotective perfusion) and not field vitrification or field cryopreservation.

The idea of field cryoprotection is not new and various proposals to introduce the technology have been introduced in the past (including proposals for real field vitrification and shipping below the glass transition temperature). In June 1990 Alcor patient A-1239 received a field cryoprotection with glycerol in Australia prior to shipment on dry ice to Alcor in the USA. In addition, on October 23, 2004, the cryonics company Suspended Animation performed a field cryoprotection with glycerol for the American Cryonics Society prior to shipping the patient on dry ice to the Cryonics Institute for

long-term care. The Cryonics Institute also has authorized field cryoprotection for select (international) cases.

There are number of distinct protocol differences between this current implementation of field cryoprotection and cryoprotection at the Alcor main facility. These protocol differences are not intrinsic to either field cryoprotection or facility cryoprotection however. By historical standards, today's field cryoprotection protocols by Alcor are often more sophisticated than older facility cryoprotection protocols and even contemporary protocols at other cryonics organizations.

One concern that has often been expressed about field cryoprotection is that shipping the patient at dry ice temperature after introducing the vitrification agent could result in ice formation en-route to the cryonics facility. While this concern cannot be completely eliminated, especially when ischemic injury compromises cryoprotectant perfusion, independent results from at least three research labs indicate that this issue does not seem to be a problem for CPA solutions currently used for vitrification in cryonics. The cryobiologist Yuri Pichugin stored large volumes of VM-1 (the vitrification agent used by the Cryonics Institute) and cryoprotected cortical rat brain slices at dry ice temperature without observing ice formation after days of storage. Similar results have been observed in other animal models perfused with M22 at 21st Century Medicine. In 2012 Advanced Neural Biosciences collaborated with Alcor to specifically validate Alcor's proposed field cryoprotection protocol in the rat model and again no ice formation was found after up to 48 hours of storing the brains at dry ice temperature prior to further cooling.

These encouraging research results and experience with this protocol in companion animal cases led Alcor to authorize field cryoprotection for overseas cases that otherwise would end up being "straight freeze" cases (i.e., cryopreservation without cryoprotection).

### *Whole Body Field Cryoprotection*

In principle, field cryoprotection can be conducted in both whole body and neuro cases. Whole body field cryoprotection presents a number of distinct challenges. For starters, a lot more cryoprotectant is needed for whole body cases which for most locations would require the shipping of large volumes of

perfusate (>100 liters) to the location where the patient will be cryoprotected. Usually, though, there should be ample time for this in the opinion of the authors because most cases in which field cryoprotection is feasible and productive involve patients with a prolonged agonal “dying” phase which allows the timely shipping of perfusate. Another challenge is that for the already-large perfusate volumes to remain manageable for whole body patients, a closed-circuit perfusion system would likely be needed. Closed-circuit systems are more complex and require more expertise and experience than open-circuit systems currently used for field cryoprotection of neuropatients (or head-only cryoprotection of whole body patients).

An additional complication involves shipping the patient. Because the patient needs to be shipped on dry ice it is crucial that the cryonics organization has a suitably equipped road vehicle or can comply with airline regulations concerning dry ice and potential weight restrictions. Of course, since cold ischemia is basically eliminated during shipment it would also be possible to transport the patient by ground to the cryonics facility (in whole body cases). Shipment of whole body patients on dry ice has been historically dangerous with significant failure rates due to failure of contractors to follow precise shipping instructions, unexpected airline delays and other causes.

While it is sometimes claimed that one major difference between whole body and neuro cryoprotection involves a difference in surgical procedures, this is not necessarily the case. In case a median sternotomy is chosen to cannulate the heart or aorta both neuro and whole body cryoprotective perfusion can be conducted by just making minor adjustments. A more detailed discussion of potential surgical protocols follows.

### *Whole-Body Field Vitrification*

During 2005, various scenarios for whole-body vitrification were discussed in California during meetings attended by personnel from Suspended Animation, Critical Care Research, and 21st Century Medicine. Options included the use of a specially modified freight shipping container, or the purchase and modification of a semitrailer truck. Liquid nitrogen would be required for rapid cooling, as the demands of an electrically-powered system would exceed the capability of a reasonably sized generator. The most promising scenario

required a vehicle or freight container outfitted for procedures to be driven to a location permitting truck parking near the patient, at which point the patient would be moved to the vehicle in a small van. Meanwhile, a third vehicle would bring liquid nitrogen to the parking location.

After examining many ideas for remote whole-body vitrification, the idea was abandoned due to its logistical complexity.

### *Surgery*

There are basically three options for obtaining vascular access in field cryoprotection: femoral cannulation, aortic cannulation, and carotid cannulation.

**Femoral Cannulation.** In femoral cannulation a “femoral cut down” is performed to cannulate the femoral artery and vein in a single leg to perfuse the patient. One advantage of this approach is that femoral cannulation used to be the preferred approach for remote blood washout and the cannulae can just remain in place for subsequent cryoprotectant perfusion (even in field cryoprotection, stabilization usually benefits from a washout to accelerate cooling and removing the patient’s blood). This approach, however, would not constitute an attractive option for neuro cryoprotection because a lot of perfusate is wasted in perfusing the rest of the body. Another potential disadvantage is that in conditions of ischemia-induced edema perfusion of the brain could be suboptimal. In addition, not all patients have a healthy, patent, femoral artery that will ensure good flow. Yet another disadvantage is the large pressure drop that will occur through a narrow femoral arterial cannula, making perfusion pressure monitoring more difficult. The greatest disadvantage of femoral whole body cryoprotectant perfusion is the difficulty of obtaining adequate venous drainage through a narrow femoral venous cannula.

**Aortic Cannulation.** In a median sternotomy the chest is opened to cannulate the heart or the ascending aorta. This procedure can be used to either perfuse the whole body or, when the descending aorta (and arms) are clamped, to limit perfusion to the upper body. A major advantage of this approach is that a large organ (the heart) or the widest vessel in the body (the aorta) is selected for perfusion which reduces challenges associated with

cannulating patients with no flow (such as collapsed vessels) and ensures good flow. In a very basic version of the procedure, venous cannulation is not necessary and an opening in the right atrium will suffice for venous drainage. A concern about this approach is that too much perfusate is wasted in neuro cases. Median sternotomy used to be the standard surgical approach for both whole body and neuro cases at Alcor prior to going to isolated head perfusion for neuro patients, and as of this writing is the default approach for all cases at the Cryonics Institute. For neuropreservation cases at Alcor's facility, isolated cephalon perfusion is now the preferred method because it allows better venous drainage, better monitoring of brain perfusion (venous effluent from left and right jugulars can be measured separately), lower likelihood of pushing clots into the brain in cases of significant pre-perfusion ischemia, faster surgery, faster cryoprotectant equilibration, and decreased perfusate utilization.

**Carotid Cannulation.** Carotid cannulation involves cannulating the carotid arteries, and sometimes the vertebral arteries, in the neck of the patient. This procedure is designed to allow cryoprotective perfusion of the head. As such, this surgical approach is used in neuro cases. It is the simplest cannulation to perform. It focuses on the head (brain) of the patient and minimizes required perfusate volumes. Another advantage is that if the cephalon is perfused separately the whole stump of the head can be used for venous drainage. Disadvantages include the lack of an easy "downstream" fall-back option in case errors are made or the vessels are too fragile or damaged for perfusion. There is also the issue that a determination would need to be made about whether a patient has an intact Circle of Willis. Without this, the vertebral arteries would need to be cannulated, too, for complete perfusion of the brain. When the Circle of Willis is intact, and the head is not separated to allow occlusion of the vertebrae, some perfusion pressure loss can be expected in the Circle of Willis as arterial perfusate leaks from the Circle into the vertebral arteries and into the rest of the body.

One argument against the carotid approach is that unless cephalic isolation is used as an approach for cryoprotection, washout will also need to be restricted to the head unless the team performs two separate cannulations. This may introduce temperature differences between the head and the rest of

the body. In the authors' opinion, the strongest argument against the carotid approach is that there are limited fall-back options in case of failure. If the heart/aortic approach is used, the field team could decide to terminate efforts to conduct cryoprotectant perfusion and transport the patient to Alcor where professional surgeons can attempt carotid cannulation. Field cryoprotective perfusion should allow for a back-up plan in case of failure, which the carotid approach does not permit. The heart / aortic approach also has the advantage that it permits both neuro and whole body cryoprotection.

### *Protocol*

Designing a protocol for field cryoprotection presents five challenges:

1. Ensuring a gradual introduction of the vitrification agent (CPA) to reduce osmotic injury to the cells. When a patient is cryoprotected at the main Alcor facility this goal is achieved by gradually mixing the "carrier solution" with the cryoprotectant in a recirculating reservoir and terminating perfusion when the desired terminal concentration of the agent has been consistently observed in venous fluid. In field cryoprotection such a recirculating setup would be complicated and current field cryoprotection protocols involve introducing a series of bags with increasing concentrations of the vitrification agent. Terminologically, the current field cryoprotection protocol is "open circuit" perfusion in which venous flow is discarded, while Alcor's facility protocol is "closed circuit" perfusion in which venous flow is recirculated. In Alcor's established protocol for field cryoprotection of the head through carotids (called "Field Neuro Cryoprotection" or FNCP), bags can be (and are) overlapped using a "teeter-totter" which blurs the jump between steps, further smoothing the introduction of different concentrations.
2. Maintaining a cryoprotectant concentration ramp and peak concentration plateau that is long enough to be comparable to what is achieved in cryonics facilities utilizing closed-circuit perfusion. This is difficult with open-circuit perfusion while keeping the perfusate volumes manageable, especially for whole body patients.

3. Temperature control. At the Alcor main facility cryoprotective perfusion is started at +3 degrees Celsius and lowered to about -3 degrees Celsius for the final half of the procedure to mitigate the cryoprotectant toxicity associated with higher concentrations. In field cryoprotection, subzero perfusion presents a bigger challenge and would require an enclosure with circulating nitrogen gas and running the perfusate through a heat exchanger (HEX) capable of reducing the temperature below the freezing point of water. Alcor's current field neuro cryoprotection protocol involves keeping the temperature of the patient as close to 0 degrees Celsius as possible by surrounding the patient with ice packs, and adding antifreeze to an ice water bath to facilitate lowering of the perfusate temperature below 0 degrees Celsius.
4. Monitoring the refractive index (or BRIX reading) of the vitrification agent as the concentration increases. At the Alcor main facility the concentration of the vitrification agent is continuously monitored in the perfusion lines to observe trends. Decisions as to whether to continue or stop perfusion are made using a benchtop refractometer. In field cryoprotection continuous inline monitoring of concentration of the vitrification agent would be challenging and the current protocol requires the use of a handheld digital refractometer to make frequent refractive index (or BRIX) readings to observe trends and to decide whether to continue or end perfusion.
5. Controlling flow rate and pressure. There are two options for controlling flow of the perfusate in the patient: a pump or a hanging bag system. The major advantage of using a pump is that it provides precise control over flow rates and pressure. The advantage of a hanging bag system is that no priming of the pump and other associated challenges need to be performed. No power supply for a pump is required, and pressure spikes are limited by the height of the bags. In reality, the choice of either a pump or a bag will greatly depend on the degree of expertise and experience in the field.



The current Alcor protocol for field cryoprotection under discussion employs an 8-step bag system (including washout with B1 carrier solution), as shown in Table 4.

Bag	nM22 Concentration	Refractive Index (BRIX)
Bag 1	0%	9.8
Bag 2	5%	11.81
Bag 3	8%	13.12
Bag 4	14%	15.31
Bag 5	23%	18.94
Bag 6	50%	29.85
Bag 7	50%	29.85
Bag 8	104%	51.50

*Table 18-4. The system of stepped field perfusion used by Alcor requires eight bags containing concentrations of perfusate as shown.*

The term nM22 denotes a solution made by diluting 125% M22 solutes prepared in LM5 carrier solution with B1 carrier solution to achieve the stated concentrations. The percent concentration scale is not concentration of solutes, but percent full concentration of M22, which has defined solute concentrations. 100% M22 or 100% nM22 is also sometimes called 100% CNV (concentration needed to vitrify) to express the idea that tissue is ideally to reach full M22 solute concentration before stopping perfusion and attempting vitrification by cooling. The endpoint for perfusion in this protocol has been measurement of jugular effluent of nM22 over 49.9 BRIX refractive index (100% CNV) for over 30 minutes. This protocol ensures a concentration necessary to vitrify (CNV) in the cells without prolonged exposure to even higher concentrations.

### *Two Visions of Field Cryoprotection*

While Alcor has authorized field cryoprotection for overseas cases, during 2017 a debate was continuing about the desirability of introducing field cryoprotection for most Alcor members who are pronounced legally dead in

the United States and Canada. Issues that have been discussed include scientific, technological, and financial concerns.

Alcor's facility cryoprotection procedures are designed to closely replicate laboratory research protocols that have shown published efficacy for brain cryopreservation. They are based on established principles of organ cryopreservation for minimizing osmotic and cryoprotectant injury while eliminating ice formation. To what extent do simplified and briefer open-circuit field cryoprotection protocols compromise cryopreservation quality?

Alcor's facility infrastructure includes computerized control and recording of multiple perfusion parameters, and personnel for observation and note-taking. To what extent will field cryoprotection quality suffer because of decreased perfusion parameter control, decreased data recording, and resulting decreased quality control feedback?

Can a patient be shipped on dry ice without risking ice formation during transport to the cryonics facility?

What is the easiest and safest surgical approach? How many concentrations of the vitrification agent need to be used? Can we lower the cost of our procedures by embracing field cryoprotection?

Perhaps the most difficult question of all is: At what distance and transport time from Alcor do the disadvantages of current field cryoprotection procedures (especially no cryoprotection for the body of whole body patients) become outweighed by the advantages of avoiding long transport times at 0 degrees C?

There are some who worry that simplified field cryoprotection procedures with limited monitoring are driven by a desire to reduce costs, complexity and oversight rather than strict improvement of care and cryopreservation outcome. Yet clearly there are distances for which even the simplest field cryoprotection protocols are beneficial, such as locations with multiday transport times.

A sensible approach to evaluate these issues is to ask whether the primary aim of field cryoprotection is improvement of patient care or simply reduction of cost. While it is indisputable that the elimination of two separate deployments can lower the costs associated with Alcor's procedures (assuming field cryoprotection protocols that are deliverable by current

standby teams), these different perspectives can lead to different views on how to conduct field cryoprotection.

If field cryoprotection is primarily advocated as a means to improve patient care the most likely implementation for Alcor is to request its standby provider (currently Suspended Animation for non-local cases) to add field cryoprotection to its washout procedure. While it would be simplistic to argue that this would just involve simply adding a few bags of perfusate to the washout procedure, it should be recognized that an organization that employs professional surgeons to establish surgical access and professional perfusionists for running the pumps should be able to perform this procedure without formidable challenges. If the aim, on the other hand, is to just reduce cost and involve Alcor staff and volunteers in field cryoprotection, the most conservative surgical protocols and cryoprotection protocols would need to be followed to reduce errors.

In our opinion, it is not possible to have a sensible discussion about the nature and scope of field cryoprotection without asking who is going to perform it. If Alcor entrusts the conduct of remote blood washout to qualified independent contractors, then concerns about the absence of relevant surgical and perfusion skills may not be all that relevant. If field cryoprotection is seen as a substitute for these contracts, however, Alcor would be making a challenging leap into the unknown.

### *Alternatives for Field Cryoprotection*

The only credible alternative for field cryoprotection would be to validate and introduce organ preservation solutions aimed at securing viability of the brain, or at least perfusability of the brain, at above-freezing temperatures for much longer than is possible with Alcor's current organ preservation solution (MHP-2). In essence, this would require the design and successful validation of "brain preservation solutions" that can preserve cerebral viability for up to 24 or 48 hours of ischemia at a temperature barely above 0 degrees Celsius. While 21st Century Medicine has made a number of breakthroughs in organ preservation solution design that enable viability of the brain for much longer periods than is possible with MHP-2, these protocols require either continuous or intermittent perfusion of the patient (or the patient's brain) en route to the

main cryonics facility. This fact by itself necessitates ground transport of the patient under supervision of qualified staff, which in some cases could involve many days.

Another concern with continuous perfusion protocols is that there is little information available on their effects in cases where warm ischemia has occurred. Prior research in the art would indicate that continuous perfusion in an ischemic patient, especially in a whole body patient, will produce severe edema over a long period of time. This edema could prevent any meaningful cryoprotective perfusion at the main facility, defeating the main objective of blood substitution.

In conclusion, the most basic question is rather straightforward. If cryoprotectant perfusion can be done competently in the field, affordably, and without much sacrifice in quality, and if it can allow much better outcomes in terms of elimination of cold ischemia and ice formation, why continue the tradition of transport on ice after remote washout? In the long term, there is no theoretical reason that everything currently done in Alcor's facility operating room couldn't be done at remote locations. The challenges of designing equipment, training personnel, and funding the operation would be significant, but we may still debate how sophisticated field cryoprotection really needs to be to be beneficial at various distances.

The frequency with which personnel perform procedures is a strong determinant of the competency with which the procedures are performed. The importance of frequent performance increases with greater complexity of procedures and equipment. Even if all cryonics cases over the whole world were performed at a single facility, the number of cases at the facility would still be small by normal standards of medical practice proficiency. In the editor's opinion, for complex cryoprotectant perfusion procedures to be competently performed at decentralized locations by traveling experienced professionals will require growth of cryonics popularity substantially beyond what exists today (2019).

## 19. Cooldown to Cryogenic Temperature

After cryoprotective perfusion, a patient must be cooled to a temperature that is low enough to inhibit all potentially harmful chemical reactions, including those caused by the toxicity of any cryoprotectants that have been introduced.

In 1889, the Swedish physicist and physical chemist Svante Arrhenius proposed a formula to derive the rate of a chemical reaction from the temperature at which it occurs, in degrees Kelvin, using various constants specific to the chemicals involved. This formula is now known as the Arrhenius Equation. For many common chemical reactions occurring in mammalian biology, the equation predicts that the reaction rate will be approximately halved for each decrease of temperature of 10 degrees Celsius. This is known as the “Q10 rule,” which we have mentioned in Section 11. The rule applies approximately down to 0 degrees C, when water freezes in human tissue.

If the water in tissue is replaced with appropriate cryoprotectant chemicals, they may remain liquid at temperatures below -100 degrees C. Tissue containing lower concentrations of cryoprotectants may still freeze, but areas of frozen tissue between ice crystals will remain a viscous liquid.

Chemical reactions in the high sub-zero range (tens of degrees below 0 degrees C) are dominated by cryoprotectant toxicity. This is a poorly understood side effect of cryoprotectants, causing cells to lose viability, meaning that their ability to resume functioning spontaneously after rewarming will be impaired.

Injury from toxicity occurs on a timescale of minutes when cells are exposed to high concentrations of cryoprotectants, but the rate of damage decreases with temperature. This is why the highest concentrations of cryoprotectants are introduced into tissues at temperatures below 0 degrees C, after tissues have been protected from freezing by first introducing lower concentrations.

Cryoprotectant solutions become extremely viscous, like thick syrup, below  $-50$  degrees C. The high viscosity becomes a more important factor than the Arrhenius equation in slowing chemical reactions. As viscosity increases exponentially according to a relation called the Vogel-Fulcher Equation, chemical reactions become inhibited by the inability of molecules to move by diffusion to reach each other. At a temperature of  $-110$  degrees C, a molecule in a cryoprotectant of the type used by Alcor would need 100 years to travel as far as in one minute at 0 degrees C.

## **Ice Formation During Cooling**

Vitrification solutions used in cryonics are metastable, meaning that below a certain temperature ( $-55$  degrees C for the solution known as M22) growth of ice is thermodynamically favored. Tissues containing less than full concentration of vitrification solution may start forming ice at higher temperatures. Ice growth rate varies inversely with solution viscosity. Any ice that forms during cooling will grow rapidly at temperatures warmer than  $-80$  degrees Celsius, and continue growing slowly even down to  $-100$  degrees Celsius and below. Tissue treated with vitrification solution should be cooled below  $-100$  degrees Celsius as quickly as possible. Pausing at higher temperatures, such as dry ice temperature ( $-79$  degrees Celsius) should be avoided unless unavoidable for logistical reasons.

Tissue treated with non-vitrifiable low concentrations of cryoprotectant (e.g. glycerol) or no cryoprotectant (“straight freezing”) can and should be cooled slowly to allow time for cells to dehydrate between growing ice crystals. Unlike vitrified tissue, frozen tissue that already contains as much ice as can grow in the presence of the cryoprotectant can be stored at dry ice temperature for days. If frozen tissue is stored too long at dry ice temperature, it may “recrystallize” into larger crystals.

At temperatures below approximately  $-125$  degrees C, cryoprotectant solution viscosity becomes so high (10 trillion Poise) that cryopreserved tissue becomes glasslike and behaves as a solid. At this point the tissue is said to be vitrified, and its transition from liquid to solid is known as vitrification. The temperature at which this occurs is known as the glass transition point, often

denoted as  $T_g$ . Molecules become immobilized, and chemical changes become impossible.

However, an undesirable process known as ice nucleation can still occur even at temperatures below  $-100$  degrees Celsius. At very low temperatures, the thermodynamic tendency to form ice is so great that water molecules will rotate locally to join with their neighbors to create extremely tiny crystals known as ice nuclei. Lateral motion by diffusion is not necessary for this to occur. Therefore ice nucleation can happen even near  $T_g$  and a few degrees below it, until the process finally ceases. Surprisingly, the ice nucleation rate is actually fastest at or just above  $T_g$ .

Ice nuclei are tiny and harmless nanometer-sized objects, but are undesirable because when tissue is warmed in the future, the nuclei will have an opportunity to grow into ice crystals that are large enough to cause injury. For this reason, tissue is preferably stored at temperatures far enough below  $T_g$  to inhibit ice nucleation. The time and temperature dependence of ice nucleation, and whether it ever ceases during storage slightly below  $T_g$ , are issues that remain poorly understood.

We know of no published reports of ice nucleation at temperatures below  $-135$  degrees C. Additional cooling below this point is therefore considered unnecessary, but most patients are cryopreserved in liquid nitrogen, which has a boiling point of  $-196$  degrees C. The reasons for using liquid nitrogen, and the possibilities for other modes of storage, are discussed in Section 20.

Regardless of which temperature is used, the patient must be cooled to get there, and this is often referred to as the “cooldown phase” preceding long-term cryopreservation.

## **Cooling Fundamentals**

In Section 11, under the subhead “The Physical of Cooling,” we discussed the concept of heat transfer. Cooling occurs when heat is transferred from a location that is relatively hot to a location that is relatively cold, via convection, conduction, or radiation. Heat transfer will tend to continue until the system equilibrates, meaning that the temperatures become equal.

If all other factors are constant, cooling will be most rapid if the temperature difference between a hot location and a cold location is as great as possible. If the temperature difference diminishes as a result of heat transfer, the rate of cooling will also decrease.

Cooling will also be more rapid if the ratio of the surface area to the mass of the object to be cooled is as great as possible, and if cooling can be applied internally as well as externally. This is why blood is circulated by cardiopulmonary support during initial stabilization of a cryonics patient, and why perfusion cooling by heart-lung bypass is the most rapid method of initial cooling, removing heat from the body internally. For these same reasons, various proposals have been made to cool the body or cephalon of a cryonics patient, after cryoprotection, by perfusion with a substance that remains liquid or gaseous all the way down to storage temperature.

Fluorocarbon compounds which remain liquid at temperatures as low as  $-120$  degrees C, and cold helium gas, have been pumped through blood vessels experimentally. Technical challenges have so far discouraged this approach in cryonics cases, and cryogenic cooling of patients has always been done by removing heat from the outside of the body. This means that heat must travel outward from the center of the patient to the skin, where it is removed by a chilled gas or liquid.

## **Fracturing During Cooling**

CT scanning studies have shown that the entire brain of a patient cryopreserved under ideal conditions is capable of vitrification. Tissues elsewhere in the body do not all vitrify, and may form ice to varying extents. Still, the presence of cryoprotectant limits ice formation to much less than would form in absence of cryoprotectant.

Vitrification or freezing entails a loss of plasticity in tissues. As they become more brittle, they are less able to tolerate stress caused by unequal thermal contraction between locations of slightly differing temperature. To minimize this risk, the cooling rate is typically paused or slowed just above  $T_g$  to allow time for temperature equilibration, which we hope will relax mechanical stress.



Cooling to storage temperature must then proceed slowly, at no more than 1 degree Celsius per hour, as the vitrified patient has become increasingly vulnerable to fracturing caused by thermal stress. Although this stress can be minimized, there is presently no cooling protocol known to avoid all fracturing of human brains or bodies stored at the temperature of liquid nitrogen (-196 degrees C). We believe that some large fractures will always occur during cooling all the way to liquid nitrogen temperature because of intrinsically different thermal contraction tendencies of different tissues. This problem has been discussed in detail in “Systems for Intermediate Temperature Storage for Fracture Reduction and Avoidance,” an article published in *Cryonics* magazine and accessible on the Alcor web site.

The exact cooling profile will be recommended by the laboratory that developed the cryoprotectant, and the profile may be updated from time to time as new data becomes available. General thinking is that for vitrification solutions with a glass transition temperature (T<sub>g</sub>) close to -120 degrees Celsius, such as M22, cooling should proceed as rapidly as possible to approximately -110 degrees Celsius, and then much slower thereafter. Slowing before passing through T<sub>g</sub> incurs a penalty of increased ice nucleation, but allows some relaxation of thermomechanical stress to mitigate fracturing.

Logistical considerations for whole body patients may require confining fast cooling to a higher temperature range, such as fast cooling down to -90 degrees Celsius instead of -110 degrees Celsius. This might be necessary if transfer to a sleeping bag or other encapsulation system required for slower cooling isn't possible at -110 degrees Celsius. It's important that patients being vitrified be cooled below -80 degrees Celsius as fast as possible to get below the temperature range of rapid ice growth. If holding the temperature of the cooling medium (typically nitrogen gas) warmer than -100 degrees Celsius is necessary before encapsulation of a whole body patient, that temperature should only be held as long as is necessary for the brain core temperature (approximated by nasopharyngeal temperature) to approach the temperature of the cooling medium, and never longer than 24 hours if a vitrification solution was used for cryoprotection.

### *Alcor's Sonic Fracture Detection System*

To detect possible fracturing events, Hugh Hixon at Alcor developed a “crackphone” that is sensitive to the characteristic sound of mechanical fractures. This device uses a sensing element from an ultrasound scanner, and performs computer processing of the signal.

At the conclusion of cryoprotective perfusion, a sonic sensor may be inserted through each burr hole in the skull so that it rests between the skull and the dura around the brain. Wax is then used to fill the burr holes around the wires from the sensors. Ideally, Hixon has stated that he would prefer to insert each sensor into the brain itself, but feels that this would be unacceptable because of the injury it would cause.

Hixon believes that fracturing occurs primarily because the coefficient of thermal contraction of the brain differs from that of the skull, although other causes may be possible. If his theory is correct, fracturing should be less common in cases where more shrinkage of the brain has occurred, so that it has separated from the skull. As of 2017, no one has reviewed case data to determine if such a relationship exists.

While the patient is cooling, output from each sensor passes through an analog-digital converter to a computer where software recognizes and timestamps each fracturing event. A typical event lasts for about 4 milliseconds.

In 2011, CT scanning of several Alcor patients after cooling to liquid nitrogen temperature revealed that the sonic sensors that had been placed were not in direct contact with the brain surface. Events detected by the sonic sensors may not have been fractures, or may have been fractures that occurred elsewhere. Although organs as large as the human brain are known from direct observation to fracture often during cooling to liquid nitrogen temperature, as of 2018 there has been no correlation confirming that events observed by the sonic sensors are actually fractures in the brain being monitored.

## **Balancing Priorities in Cooling Protocols for Vitrification**

After perfusion with a vitrification solution, our goal is to reduce the patient's temperature in such a way as to cause as little tissue damage as possible. We

may also try to optimize the state of the patient for subsequent rewarming and revival in the distant future, although these two goals impose conflicting requirements, as described below.

If a patient has signed up for whole-body preservation, the optimal cooling protocol to minimize damage to the body will be different from protocol optimized for the brain. However, we believe it is wise to prioritize the brain, and therefore the protocol suggested here will be the same for neuro patients and whole-body patients.

Three kinds of damage may be caused by, or allowed by, the cooling protocol. We list them here in order of our perceived importance. (This list does not include cryoprotectant toxicity, as we regard that a lesser concern, and it is discussed in detail elsewhere in this book.)

1. Our highest priority is to minimize ice formation which compromises the fine ultrastructure of the brain, is not compatible with organized cellular viability, and probably will require advanced molecular repair technologies to reverse.

2. Our second priority is to minimize fracturing that results from mechanical stress when different areas of the brain cool at different rates. Because fracturing occurs on a larger scale, we have to assume that it will be more easily repaired.

3. Our third priority is to minimize ice nucleation. This is different from ice growth; it merely establishes a greater risk of ice formation in the future. At a very low temperature, even when a vitrification solution is so viscous that molecules cannot move, the molecules can still rotate in a way that constitutes the beginning of an ice crystal at nanoscale level. We refer to these formations as ice nuclei. The crystals cannot grow significantly, because of the viscosity of their environment. However, in the future they may form ice crystals under two conditions:

(a) If the patient is held for a long time, such as a year or more, at a temperature close to the glass transition point. This almost never happens in reality, but the theoretical possibility does exist.

(b) When rewarming is attempted as a first step toward revival of the patient. While we cannot predict the methods that may eventually be used, we feel an obligation to minimize this challenge.

To address our first priority, we advocate the following protocol. When perfusion with vitrification solution has been completed, the patient should be cooled as rapidly as possible by immersion in liquid-nitrogen vapor at  $-110$  degrees Celsius. Thereafter, the temperature should be reduced very slowly, at a maximum rate of 1 degree per hour.

The purpose of the initial rapid-cooling phase is to traverse the zone of rapid ice growth as quickly as possible, between  $-50$  and  $-80$  degrees Celsius.

It may be reasonable to pause at  $-110$  degrees if there is concern about mechanical stress, but bearing in mind our sequence of priorities, we believe the best compromise is to cool rapidly to  $-110$  and then proceed slowly to allow tissue temperature to equilibrate, until passing through the glass transition temperature (at  $-123$  degrees when vitrification has been achieved using the perfusate known as M22).

It so happens that ice nucleation tends to occur between  $-100$  and  $-130$  degrees Celsius, and therefore, slow cooling through this temperature range does increase the risk of ice nuclei. However, mitigation of fracturing is considered more important, as ice nucleation does not destroy information in the brain, and merely complicates revival in the future.

- Note that when new vitrification solutions are developed, our recommendations for the optimal cooling protocol may change. Future research on cooling methods that minimize both ice formation and thermomechanical stress may also lead to improved cooling protocols.

In the case of a neuro patient, the process of cooling to the temperature of liquid nitrogen can be completed in one small dewar. For a whole-body patient, the procedure is slightly different, as the body has to be protected, usually in a sleeping bag, which may be applied relatively early in the cooling

process, because it becomes logistically more difficult at lower temperatures. A sleeping bag unfortunately complicates the cooling process by adding a layer of thermal insulation.

The considerations and protocols described above are for patients expected to vitrify, or mostly vitrify. Patients perfused with a low concentration of cryoprotectant, or no cryoprotectant (“straight freezing”), should be cooled more slowly from the start of cooling to allow cells time to dehydrate during extracellular freezing in order to avoid intracellular freezing, which is more damaging.

### **Whole-Body Cooldown: History at Alcor**

In the late 1980s, Hixon built a large insulated bath at Alcor that could be filled with silicone oil (see Figure 19-1). A whole-body patient ready for cryogenic cooling was wrapped in plastic and strapped to a wire-mesh stretcher that was lowered into the oil. The bath was then cooled very simply by adding large pieces of dry ice. Cooling was enhanced by using a submersible pump to circulate the oil around the patient.



*Figure 19-1. Hugh Hixon sitting beside the silicone-oil cooldown box that he designed. It is now used for cooling patients in rapidly circulating liquid nitrogen vapor.*

Frozen carbon dioxide does not transition through a liquid phase when it warms. It changes directly into a gas in a process known as sublimation. Thus, when the pieces of dry ice absorbed heat from the silicone oil, they turned into carbon dioxide gas that was vented harmlessly into ambient air.

At the end of a case, Hixon dried the silicone oil (that is, he removed water from it) using a technique that he devised using plaster of paris. Even though the oil was relatively expensive, it could be reused, and the silicone bath was a simple and economical way to achieve whole-body cooling.

It was also quite efficient, as frozen carbon dioxide absorbs 574 kilojoules per kilogram of latent heat when sublimation occurs. No increase in temperature is associated with this change of state, as the heat is used entirely to break molecular bonds that were created when the substance was frozen.

A disadvantage of Hixon's system was that it could not cool the patient below  $-79$  degrees C, the temperature at which dry ice begins to vaporize. Moreover, the cooling rate of the patient diminished asymptotically as body temperature neared the temperature of the oil.

Cooldown therefore required an additional phase, in which the patient was removed from the oil bath, protected from mechanical injury by being enclosed in a sleeping bag, and suspended in a dewar. At fifteen-minute intervals, liquid nitrogen was injected into the dewar where it vaporized, lowering the temperature toward  $-196$  Celsius over approximately one week. A fan circulated the vapor to achieve uniform cooling, and eventually the temperature dropped sufficiently for the nitrogen to remain liquid. As more liquid nitrogen was added, the level rose until the patient was fully immersed. At this point the patient was placed in a pod fabricated from sheet aluminum for transfer to permanent storage in one of Alcor's storage dewars.

## **Whole-Body Cooldown: Current Protocol at Alcor**

Prior to 2005, Alcor used glycerol as a cryoprotectant. This reduced the amount of ice that formed during cooling, but still allowed tissue to freeze significantly. It required slow cooling to allow cells to dehydrate between growing ice crystals, so that they didn't freeze intracellularly. When the M22 vitrification solution was introduced, it was capable of vitrifying without forming any ice at all but, as already noted, required rapid cooling to  $T_g$  to minimize toxicity and ice growth.

To achieve rapid cooling, the original silicone oil bath was repurposed to use cold nitrogen gas. The bath is still being used for that purpose as of 2018. As before, the patient is wrapped in plastic sheet and strapped to a wire-mesh stretcher before being lowered into the box. The patient cannot be enclosed in an aluminum pod, because the standard Alcor pod is slightly too long to fit.

A separate lid is placed over the cooling box. The lid contains a plenum and a fan, which circulates vapor actively over the skin of the patient. Liquid nitrogen is injected into the box where it absorbs heat by evaporating, generating cold nitrogen gas. Typically about 100 liters of liquid nitrogen are lost through evaporation during each 24-hour period in which the box is being used.

Alcor uses computer control to maintain a programmed target temperature of cold gas inside the cooling box. If good cryoprotection has been achieved, initial cooling in vapor is as rapid as possible.

The target temperature of gas in the box for the initial fast cooling phase is ideally  $-110$  degrees C, but temperatures as high as  $-80$  degrees C have sometimes been necessary when encapsulation (sleep bag placement) at lower temperatures hasn't been logistically possible at the end of the fast cooling.

If cryoprotective perfusion has been impossible as a result of blood clotting or other circulatory problems, the initial rate of cooling is greatly reduced to allow time for cells to dehydrate by osmosis during freezing of water outside cells. This freeze-induced dehydration of cells, a standard practice in the field of cryobiology during cryopreservation by freezing, prevents water from freezing inside cells (intracellular ice formation) which is more damaging than ice growing in between cells (extracellular ice formation).

When the target temperature for the end of fast cooling is reached inside the brain, for which nasopharyngeal temperature is a surrogate measure, the patient is removed from the cooling box. The second phase of the cooldown is the same as was used formerly. The patient is placed in an opened sleeping bag that has been sprayed with liquid nitrogen. The bag is then closed and is suspended in an A9000 model dewar made by MVE, originally used for long-term storage of cryopatients but repurposed for cooldown. Cooling then proceeds over a period of days.

Finally the patient is removed for immersion in liquid nitrogen in one of Alcor's storage dewars. The transfer process for a whole-body patient takes about 30 minutes, which Hixon finds unsatisfactory, because some warming must inevitably occur.



## **Whole-Body Cooldown at The Cryonics Institute**

For many years the Cryonics Institute omitted the rapid cooling phase used at Alcor. The patient was placed in a sleeping bag immediately after cryoprotective perfusion and was suspended in a cryostat for cooling by vapor. This procedure was comparable to the second phase of cooldown at Alcor, but was not controlled in any way. The thermal insulation of the sleeping bag, coupled with absence of any method to circulate nitrogen vapor actively, meant that the entire process proceeded very slowly.

This attracted criticism that the slow process allowed far too much opportunity for cryoprotectant toxicity to cause injury. In response to this criticism, when Ben Best became president of the organization he designed an insulated enclosure in which nitrogen liquid was introduced through a tube perforated with nozzles. The liquid vaporized almost instantly as it emerged through the nozzles, and a fan circulated the vapor around the patient. This system provided faster cooling than the one which it superseded, and is still in use. It may be comparable to the whole-body system being used at Alcor. Regardless of any debates that occurred in the late 20th century regarding cooling rates used for frozen patients perfused with glycerol, fast initial cooling after cryoprotective perfusion became mandatory at both CI and Alcor with their switch to vitrification solutions in the first decade of the 21st century.

## **Neuropatient Cooldown at Alcor**

Hugh Hixon used silicone oil experimentally on neuro patients before he built the bath for whole-body patients, but within a few years he started cooling cephalons in nitrogen vapor from start to finish. This system is still being used at Alcor at the time of writing. One version is shown in Figure 19-2 and Figure 19-3.



*Figure 19-2. A neuro cooldown dewar at Alcor. Frost has accumulated from water vapor in the air while cooldown is in progress.*



*Figure 19-3. The storage dewar in the foreground is supplying liquid nitrogen to the neuro cooldown dewar in the background.*

Immediately after completion of cryoprotective perfusion, when crackphone sensors and thermocouples have been placed, a steel screw-eye is inserted into the severed base of the patient's spine, below the head. This allows the cephalon to be handled with minimal risk of damage. It is lowered by the screw-eye into a small LR40 dewar, and the mouth of the dewar is filled with a styrofoam plug about five inches thick. Nitrogen is supplied from a small reservoir dewar (seen in the foreground in Figure 19-3).

Initial cooling is a rapid plunge to  $-110$  degrees, a temperature which Hixon chose because it is comfortably higher than  $-117$  degrees, which is the highest temperature at which he has ever observed a fracturing event. (If a patient has been perfused with glycerol as opposed to M22 cryoprotectant, the rapid plunge terminates at  $-85$  degrees.)

After the plunge, the gradual cooling phase begins. This is controlled by software which uses an initial temperature, a final temperature, and the desired cooling period to calculate a gradient which is approximately linear.

The software controls a solenoid valve that allows short bursts of liquid nitrogen from the reservoir dewar to pass into the neuro dewar. Each burst lasts about 0.7 second, and the bursts are separated by intervals of up to several minutes. Temperature is monitored using thermocouples that were placed in the cephalon, in addition to thermocouples measuring the vapor temperature inside the neuro dewar. Slow cooling from  $-110$  degrees to liquid-nitrogen temperature takes about three days.

Typically, crackphone monitoring detects 15 to 25 fracturing events during this process. Hixon has tried changing the cooldown rate from 1 degree per hour to 0.25 degrees per hour, but feels that the number of events was about the same.

When cooldown is complete, the neuro dewar is slowly filled with liquid nitrogen. This causes an abrupt reduction in temperature of about 2 degrees. A laser is used to detect the rising liquid level.

A cube-shaped styrofoam box with detachable lid is prepared for neuro transfer. A cylindrical aluminum storage cylinder measuring approximately 10 inches in diameter and 12 inches in height is placed in this box. An example is shown in Figure 19-4. This cylinder, commonly referred to as a “neuro cannister,” is lined internally with soft Dacron fiber. The fiber is saturated with liquid nitrogen, and a small pool of liquid nitrogen is poured into the bottom of the can, before the cephalon is lowered into it. The can is then filled with liquid nitrogen, and an aluminum lid is wired into place. The lid and the can are labeled with the date and the patient identification number. The can is moved to a storage dewar for immersion in liquid nitrogen.



Figure 19-4. A cannister for long-term maintenance of a neuro patient at Alcor Foundation.

## **Neuropatient Cooldown at Cryonics Institute**

Prior to the arrival of Ben Best, the Cryonics Institute did not offer neuropreservation as an option. When Best took over as president of the organization, he designed a box-shaped insulated enclosure for cooling cephalons using liquid nitrogen vapor circulated by an internal fan under computer control. This is a smaller-scale version of the whole-body cooling system at CI, described above.

## **Cooldown Following Field Neuro-Vitrification**

The initial rapid cooling of a cephalon following field vitrification is achieved simply by surrounding the cephalon with dry ice in the transport box. This system has been discussed in Section 16 discussing remote blood washout.

## **Whole-Body Cooldown Box at Suspended Animation**

During 2005, staff at Suspended Animation fabricated a proof-of-concept cooldown box at the Boynton Beach facility in Florida. This is shown in Figure 19-5.



*Figure 19-5. Prototype rapid cooldown box designed by Charles Platt and Gary Battiato at Suspended Animation in 2005. The fans were driven by motors mounted externally on the lid of the box. Sheets of foam board were used as insulation.*

Plywood was used for speed and economy of manufacture, but if the system had been fully developed, it would have been rebuilt from stainless steel and/or aluminum.

Liquid nitrogen was injected via a perforated galvanized pipe visible around three edges of the interior. The patient would be introduced to the box on a stainless-steel tray (visible at bottom-right), through a hinged door at the

end of the box. Fans circulated vapor through a hollow lid, which could be opened, as in the photograph, to allow maintenance access.

The box was tested using bags filled with liquid to simulate the mass of a patient. After two trials, development was discontinued. More detailed analysis suggested that the vapor circulation rate may have been unnecessarily high in this prototype.

## **Other Alternatives**

In 2008 Suspended Animation was asked to develop a whole-body rapid cooldown enclosure that would increase the cooling rate while minimizing localized temperature variations. Hypothetically, the enclosure might be used for cooldown during transport in a specially designed ground vehicle after remote whole-body washout.

The change of state at the moment when liquid nitrogen boils will absorb far more heat than cold vapor after boiling has occurred. Therefore, the SA design promoted boiling inside a network of tubing, so that the tubes would absorb heat.

Preliminary sketches suggesting this method are shown in Figure 19-6 (end view) and Figure 19-7 (side view). Inside an enclosure, air circulates around the patient to eliminate “hot spots.” Around the enclosure, liquid nitrogen is introduced through tubing, and either vaporizes inside the tubing and is allowed to escape through small perforations. The tubing absorbs heat from the interior shell of the box.



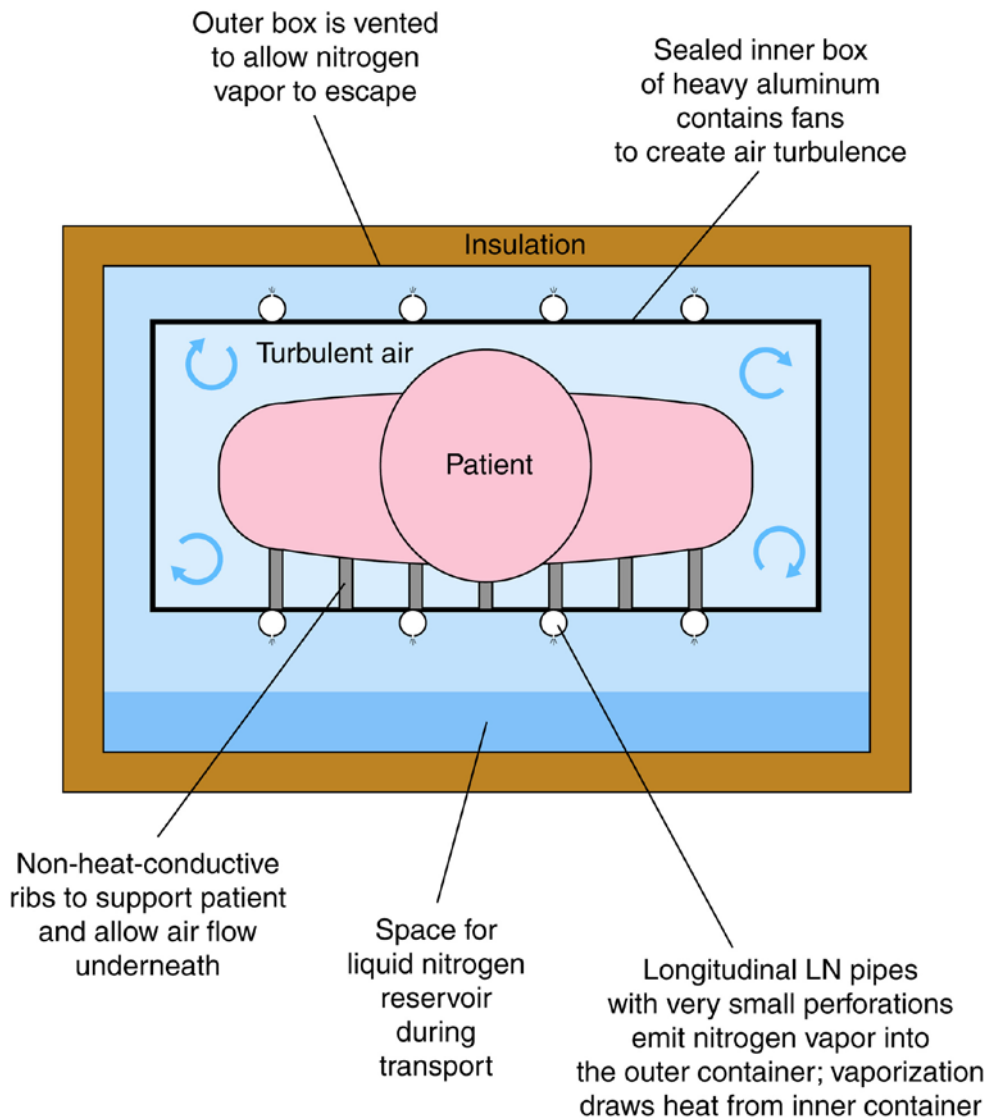

*Figure 19-6. Sketch for an enclosure to provide a controlled temperature environment for cooling with maximum efficiency and uniformity, in a hypothetical scenario for patient transport after remote whole-body blood washout.*

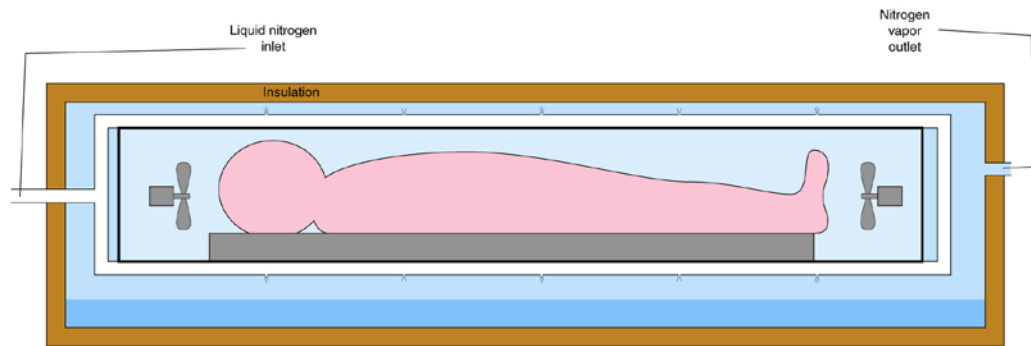

Figure 19-7. Side view of the cooling enclosure shown in Figure 19-6.

Suspended Animation also created a 3D rendering of a proof-of-concept version. It proposed a hollow framework of one-inch square-section aluminum tubes, as shown in Figure 19-8. All of the tubes would be open to each other internally, by drilling holes in them before welding them together. Liquid would be introduced in the tube at the bottom, and would rise up the side tubes, vaporizing as it did so. It would be vented from a short vertical tube at the far end.



*Figure 19-8. 3D rendering of a design for rapid cooling. The square-section tubing is hollow and is internally interconnected. Liquid nitrogen is injected into the tube at the bottom, and vapor is vented through the short vertical tube at the far end.*

In addition, channel-section aluminum strips would be mounted inside the box, to act as a giant heat sink, as shown in Figure 19-9. Ultimately a tray could be inserted to support the patient, as shown in Figure 19-10. Two fans at the far end would draw air over the patient and recirculate it under the tray.

A master welder who was employed by Suspended Animation at that time constructed the skeletal form of the cooling system shown in Figure 19-9, excluding the fan panel at the end. Sheets of 16-gauge aluminum were added around the framework, and foamboard thermal insulation was attached to all six exterior faces of the box.



*Figure 19-9. The design from Figure 19-8 with channel-section aluminum strips added to act as heat sinks. Color has been added to enable easier identification of the parts, and has no other significance.*

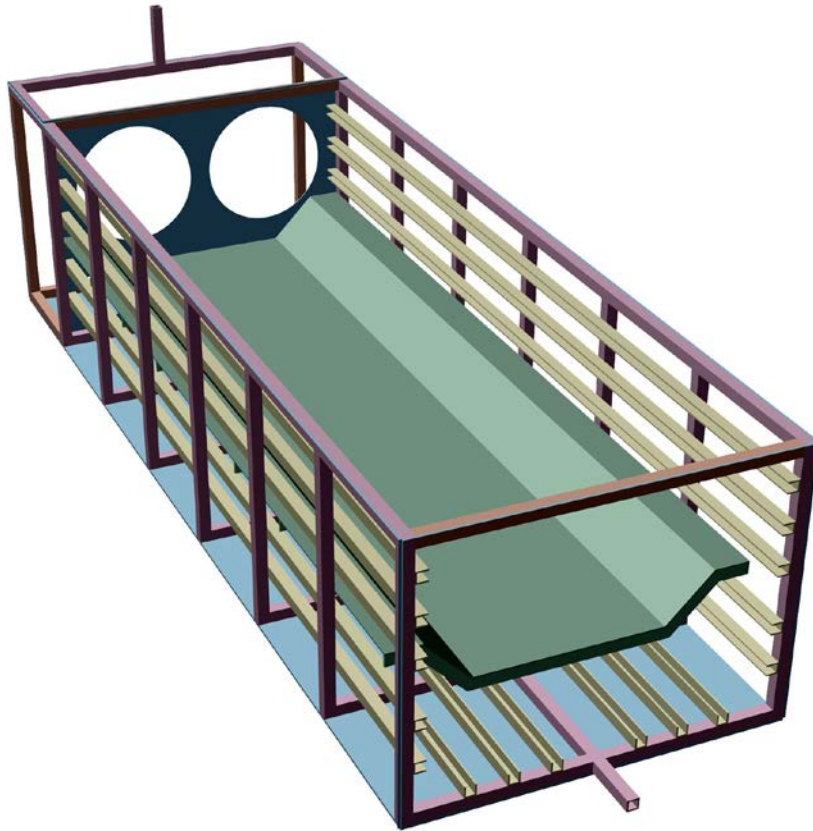

*Figure 19-10. The design from Figure 19-9 with a tray added to support a patient. Fans would be used in the panel at the far end, to circulate air internally. (A tray was never added to the prototype that was built.)*

An initial test was performed to find out if vapor locks would occur. This was a significant concern, because vapor might form under liquid in some of the tubes with unknown consequences.

Liquid nitrogen was introduced, and vapor from the end tube was piped through a two-inch hose that exhausted outside the facility. After approximately one hour, the interior of the box had stabilized at approximately  $-160$  degrees Celsius. No vapor locks occurred, and the experiment ended.

When the box was broken down for inspection, small cracks were found where side ribs had been welded to the central tube at the bottom. An engineer with experience in high-temperature steam tubing believed that the cracks had

been created by thermal contraction of the bottom tube, and suggested that the problem could be eliminated by using standard practice whereby direct runs of tubing should be eliminated in favor of a zig-zag pattern that would distribute contraction forces.

Unfortunately the welder was unable to prolong his stay at the design facility in California, and these modifications were never made. At the time of writing, any plans for rapid-cooling equipment at Suspended Animation do not appear to exist.

## **Developments at Alcor**

When Tanya Jones and Steve van Sickle acquired administrative roles at Alcor Foundation in 2005, they announced that they were going to re-think and re-engineer equipment used in all phases of cryonics cases. All of the standby kits that had been deployed around the country would become obsolete, a new ice bath would be designed, a new field-perfusion system would replace the Air Transportable Perfusion kit (ATP), and a new system enabling whole-body cooldown would be installed at Alcor's facility. This would be a dual-purpose enclosure so that perfusion and rapid cooldown could occur within the same equipment..

At an open house where Alcor displayed some of the new designs, van Sickle mentioned that the perfusion-and-cooldown enclosure had been tested to -79 degrees Celsius, but a few years later, Hixon stated that the design had suffered from heat losses to such an extent that it wasn't practical. Some modifications were made, but the prototype experienced other problems and no longer exists. While a single enclosure for perfusion and cooldown may still be an attractive concept, there are no plans to pursue this at Alcor at the time of writing.

## **Developments at Cryonics Institute**

Following the departure of Ben Best, we are not aware of subsequent cooldown innovations proposed or implemented at CI.

## 20. Long-Term Patient Care and Maintenance

Patients who have been cryopreserved for the indefinite future are sometimes described informally as being “in storage.” This term unfortunately implies that they are comparable to products in a warehouse. The phrases “long-term care” or “long-term maintenance” are preferable, and will be used here.

Similarly, Alcor refers to the location of its cryopreserved patients as the “Patient Care Bay” (shown in Figure 20-1). Patient care during long-term maintenance includes not only protection of patients from all forms of harm, but necessary physical handling such as transfers to different containers.



*Figure 20-1. Alcor’s patient care bay photographed in 2017. The original white dewar that once contained Dr. James Bedford is just visible in the center at the far end of the floor space.*

## **Options for Maintenance**

Ever since the earliest days of cryonics, the primary goal of all organizations has been to prevent chemical reactions in the human body by maintaining patients at a low temperature. While other methods of preservation are available, such as chemical fixation, reversal and revival will require major repairs on a molecular level. Generally speaking, we believe that maintenance at a low temperature may enable a better chance of revival than other options, provided we use precautions to minimize injuries associated with the cooling process.

The question is, how low a temperature is low enough?

As has been discussed in Section 17, transport of a patient from a remote location to a cryonics facility is often done in water ice. While this may be acceptable during the time taken for transport, it is not acceptable for long-term maintenance.

Carbon dioxide freezes at  $-79$  degrees C, at which point it is often referred to as “dry ice.” Because it can be obtained from many retail sources and is not expensive, it has been used for temporary preservation of cryonics patients when other options were unavailable, and is still used for transports that may take more than 24 hours—for example, from an overseas location.

Because the temperature at which dry ice vaporizes is  $-79$  degrees C, tissue treated with vitrification solution will remain liquid and will be unstable against chemical change. The vitrification solution will also be unstable against formation of ice crystals. Therefore, dry ice is not suitable for long-term maintenance of cryonics patients.

The ideal maintenance temperature for a vitrified patient will be below  $T_g$ , the glass transition point, as discussed in Section 19. Therefore, a long-term maintenance temperature is ideally colder than  $-130$  degrees C.

Low-temperature refrigerators are available commercially, capable of maintaining that temperature, but have been used very rarely in cryonics. They are expensive and relatively unreliable in the long term. They also create substantial waste heat, so that ventilation or active cooling of the environment may be necessary. For example, the Harris Cryostar laboratory freezer unit, further discussed below, can maintain samples at  $-130$  Celsius but generates



so much heat from its 5 kilowatt electrical power draw that additional room air-conditioning is required to operate it reliably. A dewar system is preferable in several respects, as discussed below.

Most cryonics patients are usually immersed in liquid nitrogen for long-term maintenance. This is an attractive option in several respects.

A warmer object will transfer its heat into the liquid, increasing its rate of vaporization. So long as this process continues, the temperature of the liquid remains constant. This results in a stable maintenance temperature, so long as liquid remains. The system has no need for the thermostat, pumps, or power supply that are required in conventional refrigeration. The liquid lost through vaporization is often referred to as *boiloff*.

In conventional medicine, liquid nitrogen is used to cryopreserve sperm, ova, embryos and some tissue samples. In cryonics, it was used for the cryopreservation of the first cryonics patient, Dr. James Bedford, in 1967. Immersion under liquid nitrogen is still the most widely used method of patient maintenance in cryonics today.

Fortuitously, liquid nitrogen is created as a common industrial byproduct and can be delivered in most urban areas in a tanker truck. Purchased in bulk, it costs between 10 and 20 cents per liter (in 2017 prices). If a cryonics organization maintains a bulk storage tank, this can be used as a distribution point to top off insulated containers as required. The system offers several advantages:

- Very reliable.
- No power supply needed.
- Silent and odorless.
- Because nitrogen is relatively nonreactive, it can be allowed to come into direct contact with the patient.

However, there are some disadvantages:

- Maintaining patients reliably at a temperature other than  $-196$  is difficult (although not impossible).

- When all of the liquid has vaporized, the temperature is no longer constrained.
- Reliable deliveries from a local supplier are required. The equipment and electric power necessary to liquify nitrogen from air on site would be several times as expensive as delivered liquid nitrogen, making such systems impractical except as expensive emergency backup.
- Handling nitrogen at  $-196$  can be physically hazardous. Precautions are necessary.
- If the heat insulation of a container fails, liquid nitrogen will vaporize rapidly.
- Uncontrolled release of nitrogen gas in an enclosed, unventilated area can cause asphyxiation.
- Rapid vaporization fills an enclosed area with white mist that can reduce visibility almost to zero.

Cryonics organizations have been unanimous in their belief that the advantages of liquid nitrogen outweigh the disadvantages. The question is how to contain the liquid safely and reliably, minimizing heat incursion so that replenishment is required on a relatively infrequent basis.

## **Dewars and Cryostats**

A cryostat is a vessel capable of maintaining a static cryogenic temperature (below  $-100$  degrees C) internally, by any method. A dewar is a type of cryostat that is insulated by high vacuum and internal thermal radiation reflectors.

In the field of cryonics, the Cryonics Institute uses cryostats that are insulated by soft-vacuum and perlite and are fabricated from fiberglass. Alcor has preferred to use dewars fabricated from stainless steel, fabricated by companies that specialize in cryogenic storage.

In either case, an inner container is nested inside an outer container, the two being joined at the top, as shown in Figure 20-2.

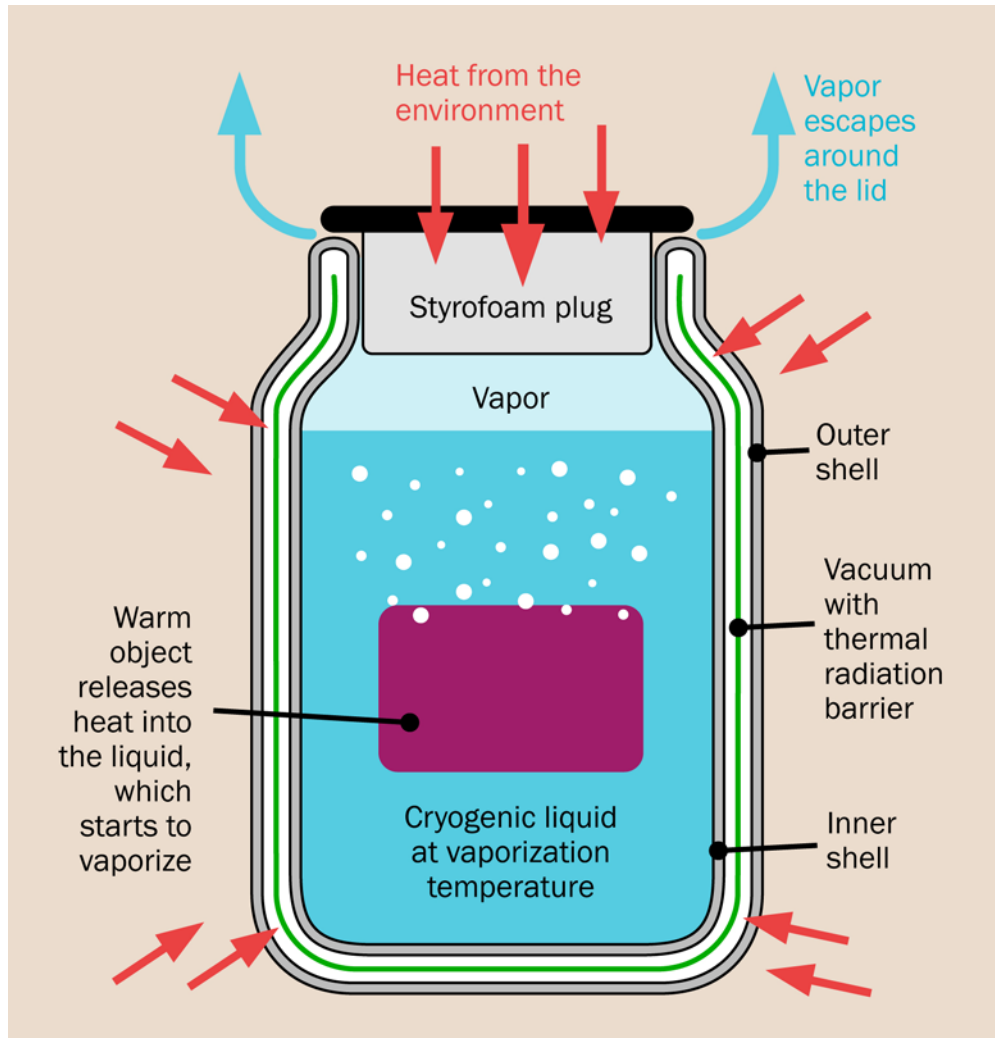

Figure 20-2. Basic features of a double-walled cryostat or dewar.

Bearing in mind that heat is transferred by convection, conduction, and infrared radiation, a dewar or soft-vacuum cryostat prevents heat incursion in all three ways:

**Soft-vacuum Cryostat**

- Conduction is minimized by separating the inner shell from the outer shell by approximately one foot, filling the space with porous perlite pellets, and removing air from this space to create a soft vacuum that within the perlite is more insulating than ordinary foam insulation of the same thickness.
- Convection is reduced by removing almost all air from the space between the inner and outer shell, and restricting movement of remaining air by filling the space with perlite.
- Radiation heat transfer is blocked by presence of the opaque perlite between the inner and outer shells.

**Dewar**

- Conduction is minimized by separating the inner shell from the outer shell by approximately one inch, and removing practically all air from this space so that the mean free path of air molecules becomes greater than the space between the shells (the threshold condition for vacuum to become thermally insulating).
- Convection is eliminated by removing practically all air from the space between the inner and outer shell.
- Radiation heat transfer is blocked by including multiple thin layers of reflective mylar “superinsulation” in the vacuum space between the shells.

The advantages of soft-vacuum cryostats are that the vacuum necessary to operate (determined by making the mean free path of air molecules larger than the very small porous cells inside the perlite) is easier to achieve than the high vacuum required by dewars, and vacuum failure is not as urgent as vacuum failure of a dewar because the thick perlite-filled wall of a soft-vacuum cryostat is a reasonably good thermal insulator even without vacuum. The advantages of a dewar are its much smaller external size and greater

portability for a given internal volume, because the wall of a dewar is very thin.

In the early days of cryonics, obtaining a suitable container for patients was the single largest expense, creating an initial barrier to providing any kind of service.

## **History**

When Robert Ettinger's book *The Promise of Immortality* was published in 1964, readers who became excited by the concept assumed that large corporations would take on the task of fabricating the equipment and developing the procedures that seemed urgently necessary.

"The time for action is now," New Yorker Saul Kent wrote in a personal letter to Ettinger. "Research must be intensified! People must be properly informed and persuaded! Equipment for body preparation and facilities for storage must be made available!"

Ettinger shifted the onus back to Kent, suggesting that he should contact Curtis Henderson, another reader who had contacted him from the New York metropolitan area. Together they founded one of the first organizations, the Cryonics Society of New York (CSNY), with Karl Werner, who coined the term "cryonics."

Dewars were already in common laboratory use to preserve biological samples, but were not generally large enough to contain a human body, and none of the founders of CSNY had enough money to commission a custom-built vessel. However, Henderson owned stock in Union Carbide, so he went to a stockholder meeting. "I suggested they should build tanks for us," Henderson recalled in an interview many years later, "and of course they gave me a look, like—well, I got used to that look during the next few years."

Meanwhile, Robert Ettinger was appearing on TV talk shows, stating that businesses had already been formed and were ready to freeze people. "The Johnny Carson show," Kent recalled later, "was very big then . . . [Ettinger] showed a drawing of a facility allegedly being built by a company called Cryolife in Kansas City, Missouri, and he just repeated what they guy

had told him, and said there were going to be thirty of these in existence by the end of the year.”

“I was sure it wasn't true,” says Henderson. “There were just some people out there looking for money. And there was no money.”

To settle the matter, Henderson and Kent drove across the country, checking out the businesses that Ettinger had publicized. None of them turned out to be genuine until they found a man named Ed Hope in Phoenix, Arizona.

Hope ran a small company that imported wigs from Germany, but he had made enough money to equip a manufacturing facility, had hired a couple of engineers, and was building his own cryogenic storage tanks. “We spent a couple of weeks there,” Henderson recalls, “learning about high vacuum, helium-leak detectors, and all the rest of it. By this time we were facing the fact that cryonics was going to be a back-alley kind of thing.”

Henderson gave Hope \$200 as a down payment on a tank. Hope wanted \$1,000 but he allowed the debt to be paid off over 32 months at \$25 a month. This is how CSNY came to be the first cryonics organization to own the fundamental piece of equipment that would enable them to cryopreserve a human being.

Kent and Henderson extended their cross-country journey to Los Angeles, where they met Robert Nelson, president of the Cryonics Society of California. Nelson ran a TV-repair company, but had greater ambitions. Unfortunately, Henderson’s work as an insurance adjuster had taught him how to run a credit check. “He was telling me all these things,” Henderson recalls, “but I’d already found out that his wife was supporting him by working as a teller in a bank.”

Despite its humble origins, CSNY became the largest cryonics organization in the country. But as things worked out, Robert Nelson stole the first share of glory. In June, 1966, a biologist named James Bedford had written to Robert Ettinger offering to fund cryopreservation research. Bedford’s interest soon turned out to be personal: He had been diagnosed with liver cancer, which had spread to both lungs, and he was starting to consider the possibility of being frozen himself.

Since Bedford lived in Southern California, Ettinger referred him to Robert Nelson. Nelson later claimed that freezing someone was the last thing

he wanted to do, because he wanted to fund serious research, and he feared the consequences of sensationalistic publicity. Still, when Bedford was pronounced dead on January 12th, 1967 at the age of 73, Nelson organized the effort to freeze him. The rather primitive procedures were written up in *Life* magazine, after which Nelson overcame his shyness and made public appearances to promote the concept of cryonics.

James Bedford was transported on dry ice in a U-Haul vehicle to Phoenix, where he was installed in one of Ed Hope's tanks. He had left a bequest intended for research, and some of this money was probably used to finance his own long-term maintenance. In 1973 he was relocated with the Trans Time cryonics organization near Berkeley, California. He remained there until his family took possession of him, still in the same tank, in 1977. In 1982 he was moved to Alcor, and in 1991 his body was transferred into one of Alcor's dewars. The tank in which Bedford had resided remains on display in Alcor's patient care bay, and is shown in Figure 20-3. Figure 20-4 shows Curtis Henderson in his back yard in Sayville, Long Island, in a photograph taken in 1992.

Henderson legally died in 2009 and was cryopreserved by the Cryonics Institute.



*Figure 20-3. The original dewar that contained James Bedford, MD. The EverAfter logo on the endcap was from later use as a movie prop.*



*Figure 20-4. Cryonics pioneer Curtis Henderson in his back yard in 1992, with an unknown tank formerly used for human cryopreservation.*



The horizontal configuration used by Hope facilitated the installation of a patient on a narrow steel table that slid into the tank on runners, but the lid then had to be welded shut. Pipes that penetrated the lid allowed liquid nitrogen to be refilled and vented, and also allowed the use of a vacuum pump if necessary.

Curtis Henderson was the first to see the advantage of rotating a dewar to a vertical position, which eliminated the need for the vessel to be sealed and allowed removal of a patient if circumstances required it. All of the dewars and cryostats at Alcor and the Cryonics Institute now have a vertical configuration.

## **Equipment at Alcor**

At Alcor, dewars capable of holding two whole-body patients were used until the number of cases justified a larger container. The so-called bigfoot dewar (named because of the five large casters that protrude around the edges of its base) has become the default size, with sufficient space for four whole-body patients plus five neuropatients in a central column. A bigfoot dewar is shown in Figure 20-5.



*Figure 20-5. A bigfoot dewar at Alcor Life Extension Foundation.*

A four-person dewar justifies its higher cost of fabrication by reducing the boiloff of nitrogen, amortized on a per-patient basis. However, this economy of scale is not fully realized until the dewar is filled with patients. A

bigfoot containing only one patient will actually be more expensive to maintain than a single-person or two-person dewar containing one patient.

The bigfoot design was modified as a result of a suggestion by Paul Wakfer, who in the 1990s was the owner of a long-term cryonics maintenance organization named CryoSpan (not to be confused with a company called Cryo-span that was associated with the Cryonics Society of New York 30 years earlier). Wakfer calculated and demonstrated that if the dewar was made about 10 inches taller, a thicker styrofoam plug beneath the lid would reduce the rate of boiloff sufficiently, in the long term, to outweigh the extra cost of fabrication. This is because the wall of a dewar blocks heat transfer so effectively that practically all heat leaking into a dewar comes down the foam plug and adjacent inner shell at the top or “neck” of the dewar. Neck design is therefore the most important determinant of dewar performance. Alcor adopted Wakfer’s idea.

The vacuum between the inner and outer shell of Alcor’s bigfoot dewars is rated at 4 microns, although in practice Alcor’s research fellow, Hugh Hixon, states he has measured values below 1 micron. Pressure may be described using millimeters of mercury, originally defined as the additional pressure that would be exerted by a column of mercury of that height. A micron is 1/1000 of a millimeter; thus, 1 micron of pressure = 0.001 millimeters of mercury.

The inner shell of a bigfoot is separated from the outer shell by about 1 inch (2.54mm). Within this gap are 70 layers of silvered Mylar that are “dimpled,” meaning that each layer has tiny dimples stamped into it to separate it from the next layer and minimize contact. The Mylar is described as “superinsulation,” and inhibits radiative heat transfer.

The bigfoot design contains four “pods,” each being fabricated from sheet aluminum and sized to contain a single whole-body patient. Perforations in the pods allow liquid nitrogen to flow in while they are being lowered into a dewar.

The two parts of a pod are shown in Figure 20-6, while Figure 20-7 illustrates how a patient is strapped in. Patients are oriented head-down so that in the unlikely event that liquid nitrogen boils off rapidly, the head will be the last part to experience an increase in temperature.

A neuro patient, protected inside a cannister of the type illustrated in Section 19, may be stored in a relatively smaller dewar of the type shown in Figure 20-8. Alternatively, the bigfoot configuration allows room in the center of each dewar for a “neuro column” as shown in Figure 20-9. Five neuropatients can be stacked vertically in the column, or space at the top can be allocated for a companion animal.



*Figure 20-6. The two sections of a pod that is designed to store a whole-body patient for immersion in liquid nitrogen at Alcor.*



*Figure 20-7. A mannekin illustrates the way in which a whole-body patient is strapped into a pod. In reality, the patient would be wrapped in a sleeping bag.*



*Figure 20-8. A neuropatient being lowered into a neuro dewar at Alcor.*



*Figure 20-9. A neuro column is designed for insertion into the center of a bigfoot dewar, among the whole-body pods.*

A whole-body pod may alternately be configured to contain 10 neuro patients, each in a separate compartment, as shown in Figure 20-10.



*Figure 20-10. A whole-body pod can be reconfigured to hold 10 neuropatients, each in a separate compartment.*



The footprint of the pods in a bigfoot dewar is shown in Figure 20-11, and is illustrated in Figure 20-12 using a 3D-printed model created by Steve Graber at Alcor.

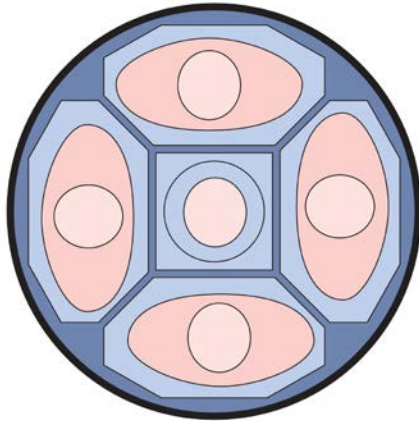

*Figure 20-11. Four whole-body pods and a neuro column (all shown in pale blue) containing patients in a bigfoot dewar, seen from above.*



*Figure 20-12. This 3D print by Steve Graber at Alcor shows how the pods and neuro column fit into a bigfoot.*

Recognizing that some Alcor members are larger than others, Hugh Hixon developed an alternate design in which two oversized pods can occupy the same space as three normal pods, as shown in Figure 20-13. At the end of 2017, two patients had required oversized pods.

Taking the concept a step further, Hixon has designed a “sumo pod” that would occupy half of the interior, but at the time of writing, no Alcor member has required this. If it was built, it would share a bigfoot dewar with one regular-sized pod and two neuro columns.

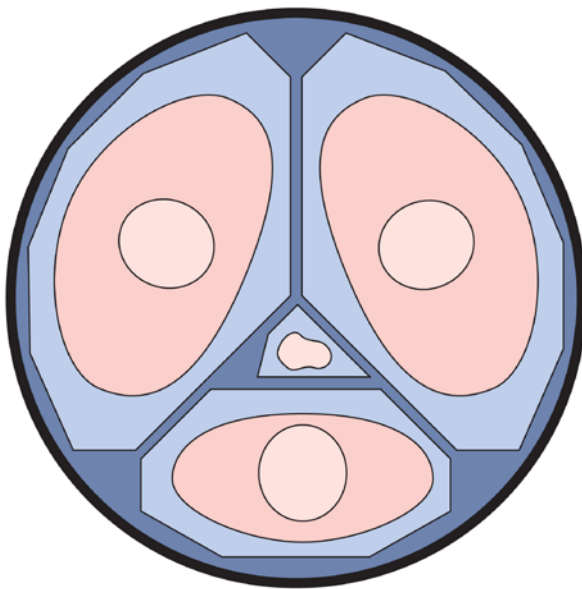

*Figure 20-13. Two oversize pods for obese patients are designed to share a dewar with one normal-sized whole-body pod. Compare this layout with Figure 20-11.*

The need for the pod system has been questioned by Steve Graber, Alcor’s Technical and Readiness Coordinator, who advocates podless storage in which each whole-body patient is strapped to a narrow backboard. This design would take less room, and thus would allow more patients to share the same amount of interior space. Graber is shown holding a prototype in Figure 20-14. Whether it will be adopted at Alcor remains unknown at the time of writing.

Hixon prefers to continue using pods because he believes that in the event of a dewar failure, they would provide some added protection and would facilitate removal of patients.



*Figure 20-14. Steve Graber, at Alcor, holding his prototype design for a patient backboard that he believes could substitute for a pod.*

Grabber has designed a “SuperD” (pronounced “super dee”) dewar to hold seven patients in standard pods (or eleven patients if podless storage is used). The first dewar of this size was delivered to Alcor in 2017, and is shown in Figure 20-15, while the interior layout is shown in Figure 20-16. A SuperD allows more efficient use of floor area than a bigfoot dewar, as shown in Figure 20-17.



*Figure 20-15. The seven-patient “SuperD” dewar designed by Steve Graber at Alcor, still being tested at the time of writing.*



Figure 20-16. The proposed packing arrangement for patient pods in the SuperD dewar.

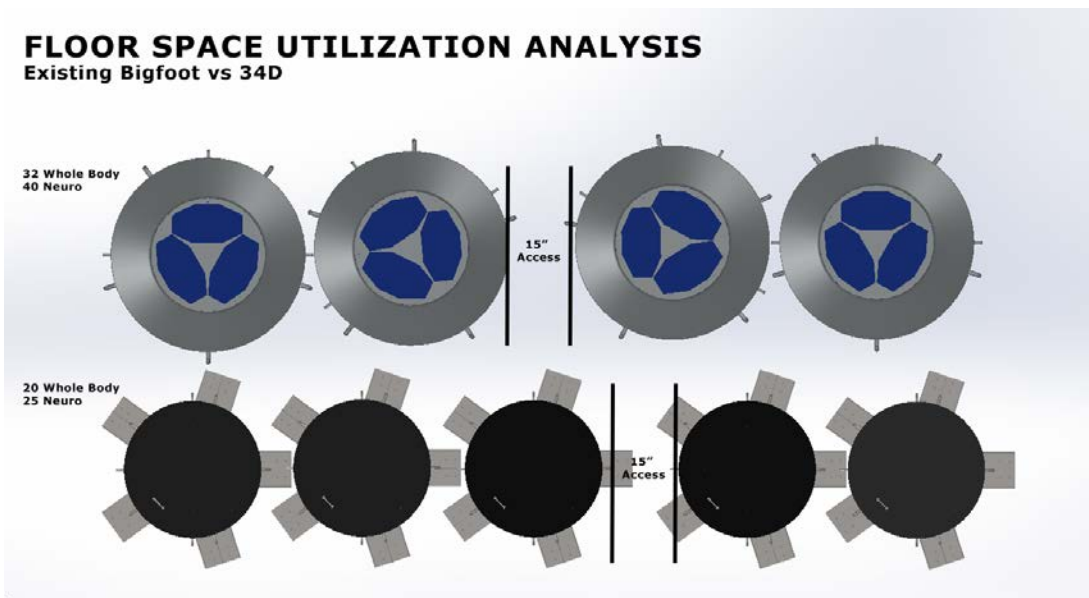

Figure 20-17. Comparison of floor-space utilization for four SuperD dewars and five bigfoot dewars.

Fabrication of the SuperD costs approximately twice as much as fabrication of a bigfoot dewar. Its weight, when filled, is approximately 6 tons. Graber hopes that eventually all whole-body patients will be moved into SuperDs, while bigfoots can be repurposed to contain neuros only.

The neck of the SuperD allows only three of the internal pods to be immediately accessible. Each of the remaining four pods must be shifted laterally into the center of the dewar for removal. This procedure is made more difficult by the height of the neck of the dewar, but Graber has fabricated a moving device consisting of a pole that descends into a sleeve in the top of a pod and locks into place.

The SuperD design will reduce the boiloff per patient when it is fully loaded. In a test of the dewar using nitrogen without patients, the level fell by about 25 inches from the fill line during 80 days. The average boiloff per day was about 15 liters, or 2.15 liters per whole-body patient. Graber estimates that if pods were installed, they would remain submerged for up to 55 days without topping off the nitrogen.

By comparison, a bigfoot dewar has a boiloff per day of about 12 liters per day, or about 3 liters per patient. Each bigfoot holds a sufficient reserve to keep the pods submerged for at least 30 days.

At the time of writing, the SuperD is completing boiloff tests and is not yet in service.

A bulk storage tank with a capacity of 900 gallons stands in one corner of Alcor's patient care bay, as shown in Figure 20-18. A delivery truck stops in the service road behind the facility once a week (as of 2017) and pumps liquid nitrogen through a flexible hose into the tank. A network of pipes and valves then distributes the nitrogen to the dewars. Some of these pipes can be seen in Figure 20-1, running laterally to each dewar.

At the end of 2017 Alcor had 155 patients preserved at its facility. This is a combined total of neuro and whole-body cases.



*Figure 20-18. The bulk storage tank for liquid nitrogen in Alcor's patient care bay. Its capacity is 900 gallons.*

## **Patient Relocation**

When Alcor left its facility in Riverside, California and moved to Scottsdale, Arizona, its bigfoot dewars were moved on a flatbed truck, fully loaded with patients and liquid nitrogen. The product of careful planning, and use of a

company that specialized in moving fragile high-value equipment such as communication satellites, the move was completed without incident.

Relocation of neuro patients is a relatively trivial procedure by comparison, as a cephalon in a small dewar can be transported in an SUV or pickup truck. Indeed, neuro patients have been moved in this manner to a local imaging center where CT scans have been performed (see below).

The size and weight of a SuperD would make relocating it while full of liquid nitrogen a challenge, although Steve Graber believes it is feasible.

## **Patient Transfers**

In Alcor's patient care bay, a winch equipped with a chain is used to raise a patient enclosed in a pod from floor level to the rim of a bigfoot dewar, after which the pod can be moved laterally and lowered into position. A similar procedure is necessary when a neuropatient is added to a neuro column in one of the bigfoot dewars. Figure 20-19 shows a column being hoisted out of a bigfoot for this purpose, while Figure 20-20 shows the column after being lowered back into the dewar. Whole body patients are protected from temperature excursions during transfers by being inside a liquid-nitrogen-soaked sleeping bag, which can additionally be sprayed with liquid nitrogen. Neuro patients are protected by their neurocanister remaining full of liquid nitrogen during movement through air at room temperature.





*Figure 20-19. Raising a neuro column from a bigfoot dewar.*



*Figure 20-20. The neuro column after being lowered back into a bigfoot dewar.*

## **CT Scans**

In 2011, when Hugh Hixon was puzzled by erratic signals that he had picked up from a crackphone in a cephalon that had been cryopreserved, he obtained permission to investigate the problem using medical computed tomography, more popularly known as a CT scan. Radiation in this type of scan will penetrate thin aluminum and liquid nitrogen, so that a neuropatient can pass through the scanner while remaining immersed and encapsulated.

CT scans had been used previously by Alcor for cryopreserved companion animals, in cooperation with a local imaging center.

By 2017, Alcor had scanned 25 neuropatients, and Hixon would like to apply the procedure to all existing neuropatients, beginning with those that experienced the longest ischemic time. Comparative studies can then evaluate the outcome of different cryoprotection protocols.

Initially the patient (in a neurocanister) is transported to the imaging center in a small LR40 dewar, along with a second LR40 containing additional liquid nitrogen. Immediately before the scan, some liquid nitrogen is transferred into a styrofoam box that has been sized and shaped to pass through the scanner, and the can is then placed in the box. The box containing an empty can is shown in Figure 20-21.



*Figure 20-21. A neurocanister is immersed in liquid nitrogen in this styrofoam carrier when it is passed through a CT scanner.*

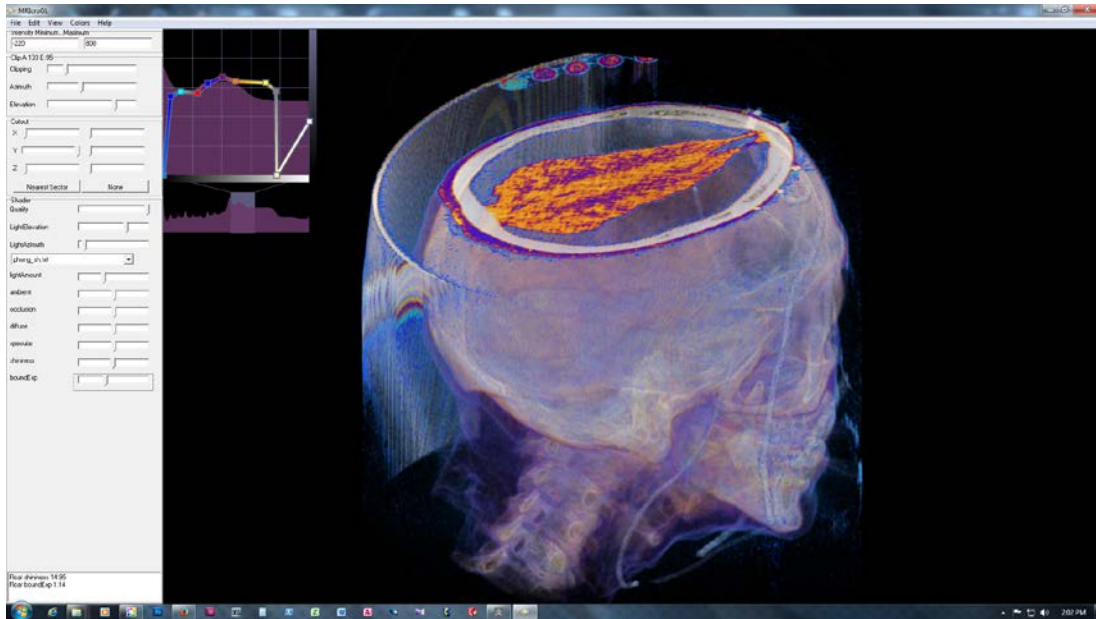

Figure 20-22. A CT scan clearly reveals the size and shape of a cryoprotected brain inside the skull, and also differentiates between frozen and vitrified areas.

Prior to this procedure, cryonics organizations could only evaluate the success of a case by using indirect evidence such as shrinkage of the brain determined by viewing its surface through burr holes in the skull.

Scanning the brain of a whole-body patient is possible if the patient is at dry-ice temperature. The body is transported to the imaging center in an insulated container open at one end. The patient is moved just far enough out of one open end of the container to allow the head to enter the scanner.

## Intermediate Temperature Storage

In 1983 Alcor received three whole-body patients who had been transferred from another cryonics facility, and was authorized to convert them to neuro patients for continued preservation. This enabled post mortem examination of the bodies, which revealed multiple fractures in many organs (“Postmortem Examination of Three Cryonic Suspension Patients,” *Cryonics* September 1984, pages 16-28, archived on the Alcor web site.)

In 1994, patient A-1242, who did not make her own cryonics arrangements, had to be removed from long-term maintenance as a result of a legal dispute between family members. This allowed an opportunity for post mortem examination, which revealed that the brain had fractured into five major pieces (“Exploring Cracking Phenomena,” *Cryonics* 1st Qtr. 1995, pages 27-32, archived at the Alcor web site.)

During the years before CT scanning became available, Hugh Hixon compiled a list of possible fracturing events detected by the crackphone that he designed (described in more detail in Section 19). See Table 20-1.)

Alcor Case	Fracture Events	Highest Fracturing Temp	Cryoprotectant	Year
A-1030	1	Bet. -108.1 and -112	Glycerol	1995
A-1486	28	-99.3	Glycerol	1995
A-1559	39	Bet. -65.8 and -68.6	Glycerol	1995
A-1475	8	-121.3	Glycerol	1995
A-1110	22	-107	Glycerol	1997
A-1069	3	-109.3	Glycerol	1997
A-2020	5	-134	B2C	2003
A-2059	18	-127	B2C	2004
A-2063	20	-117.7	B2C	2004
A-1772	20	-75	Glycerol	2004
A-1562	17	-128.4	B2C	2004
A-2068	23	-98.5	Glycerol	2004
A-2024	7	-125.6	B2C	2005
A-2071	15	-121.9	M22	2005
A-1097	5	-134	M22	2006

*Table 20-1. Total number of apparent fracturing events detected by acoustic sensors inside the cranium of cryonics patients during cooling, and temperature at which the first apparent fracture was detected.*

In the hope of minimizing fracturing events, options were discussed to maintain patients at an intermediate temperature, below T<sub>g</sub> but above the temperature of liquid nitrogen. The concept of intermediate-temperature storage came to be known by its acronym, ITS.

The first attempts to maintain patients at ITS were made when two Alcor neuro patients were held at  $-130$  degrees C in a Harris Cryostar chest-type laboratory freezer. It included a liquid nitrogen backup system that could maintain temperature in the event of a power failure, and was filled with dry ice as thermal ballast. Still, concerns were expressed about its reliability, as it sounded its temperature excursion alarm on an erratic basis. This was especially troublesome during summer months when the ambient temperature in the space where the freezer was located sometimes exceeded 90 degrees Fahrenheit, despite room air conditioning. Although the temperature of the patients always remained close to the desired temperature because of the thermal ballast, and use of the freezer allowed fracturing to be avoided down to an unprecedentedly low temperature of  $-128$  degrees C, better methods of ITS were desired. (See “Systems for Intermediate Temperature Storage for Fracture Reduction and Avoidance,” *Cryonics* 3rd Qtr. 2011, pages 7-14, archived at the Alcor web site.)

Brian Wowk, a biophysicist at 21st Century Medicine, did extensive R&D to perfect a viable ITS system that would be dewar-based, avoiding the reliability issues and heavy power consumption of the Cryostar. Wowk’s basic idea was to use very low power electrical heating elements to maintain a precise temperature inside containers of high thermal conductivity that were encapsulated by thermal insulation while being stored above the surface of liquid nitrogen in a conventional dewar (U.S. Patent 7278278B2).

Figure 20-23 shows the evolution of the concept in four simplified steps. In section A of this figure, a small pool of liquid nitrogen is at the bottom of a dewar. Because some heat from the environment enters through the lid of the dewar and makes its way downward to the liquid, the interior has a large internal temperature gradient.

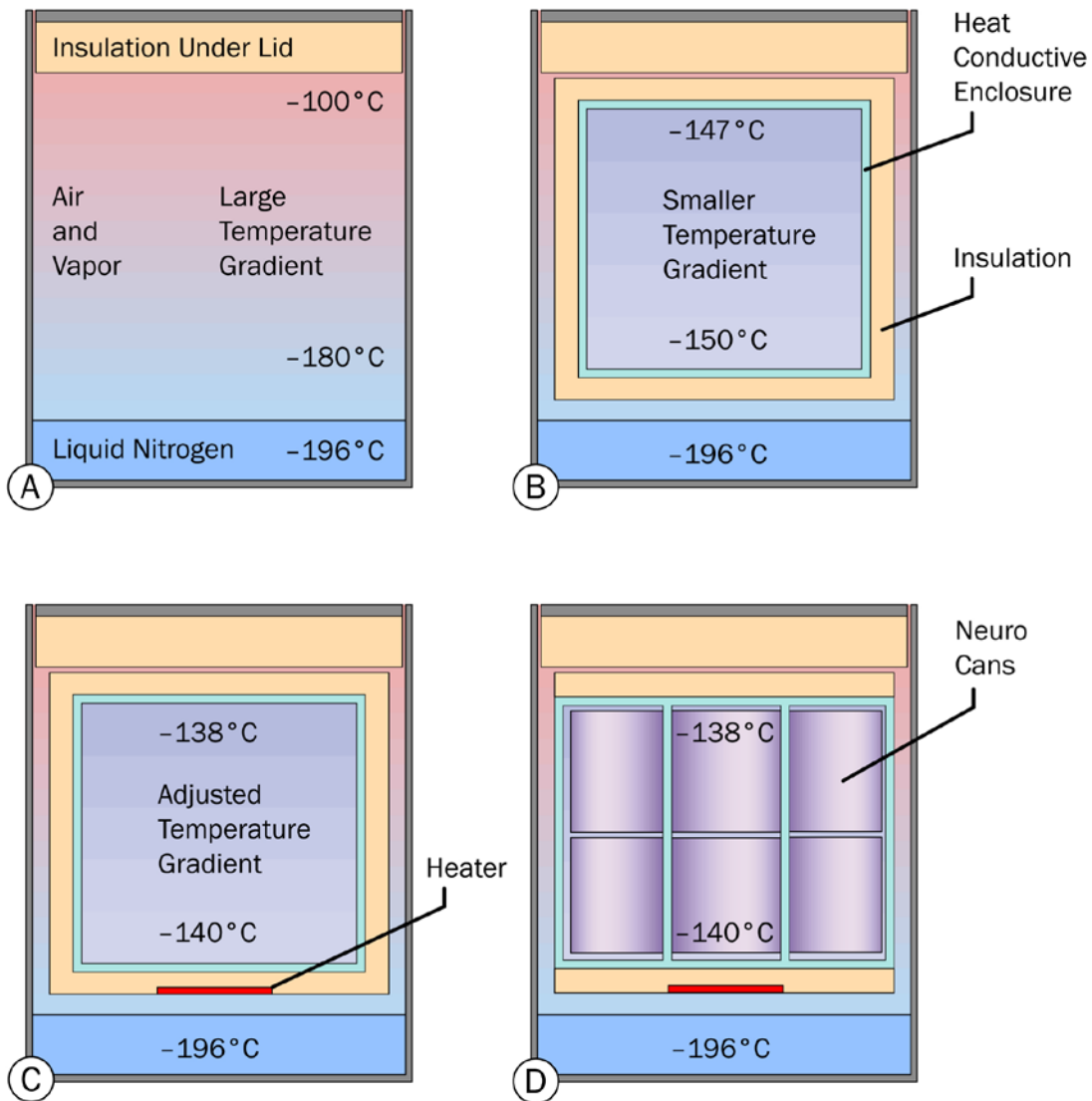
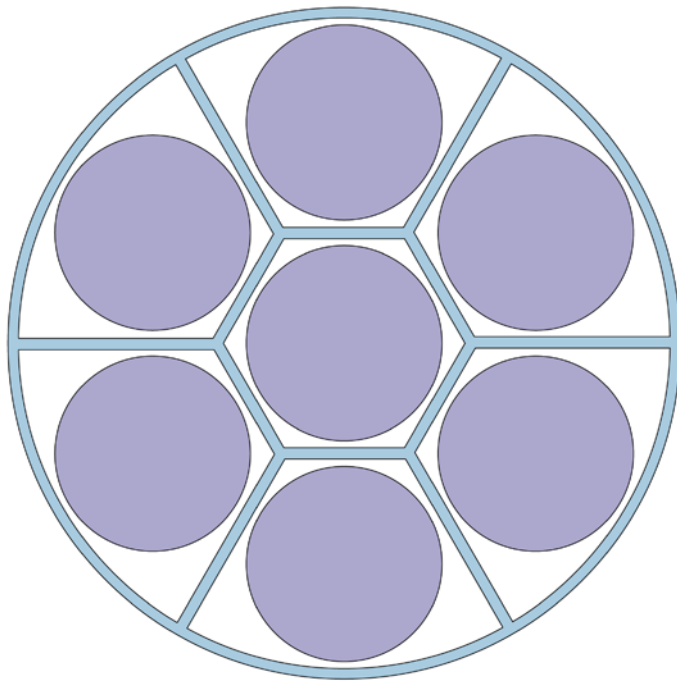

Figure 20-23. Achieving a controlled intermediate temperature for 14 neuropatients inside a dewar. See text for details.

In section B of the figure, an enclosure has been inserted in the dewar. It is fabricated from aluminum, which conducts heat very efficiently. In addition, the enclosure is surrounded with insulation. Inside the enclosure, the temperature gradient has been reduced to a much narrower range, but may still be too cold for optimum preservation of a cryoprotected neuropatient.

In section C, a heater has been added. By actively controlling the heater, the temperature in the enclosure can be adjusted upward to a desired value that is constant and relatively insensitive to temperature disturbances within the vapor space of the dewar. Section D shows this concept applied to an enclosure customized to contain 14 neurocanisters.

Figure 20-24 shows the ITS geometry seen from above (only the upper layer of two layers of stacked neurocanisters is visible). Figure 20-25 shows an exploded 3D view in which the 14 cans are displaced from the enclosure (left) and installed in the enclosure (center), with seven lids that will fit over them. The right-hand view in this figure shows the assembled enclosure with layers of insulation that will fit above it and below it when it is installed in the dewar containing a pool of liquid nitrogen.



*Figure 20-24. Neurocanisters viewed from above, placed inside a carrier to be inserted in a dewar for intermediate temperature storage.*



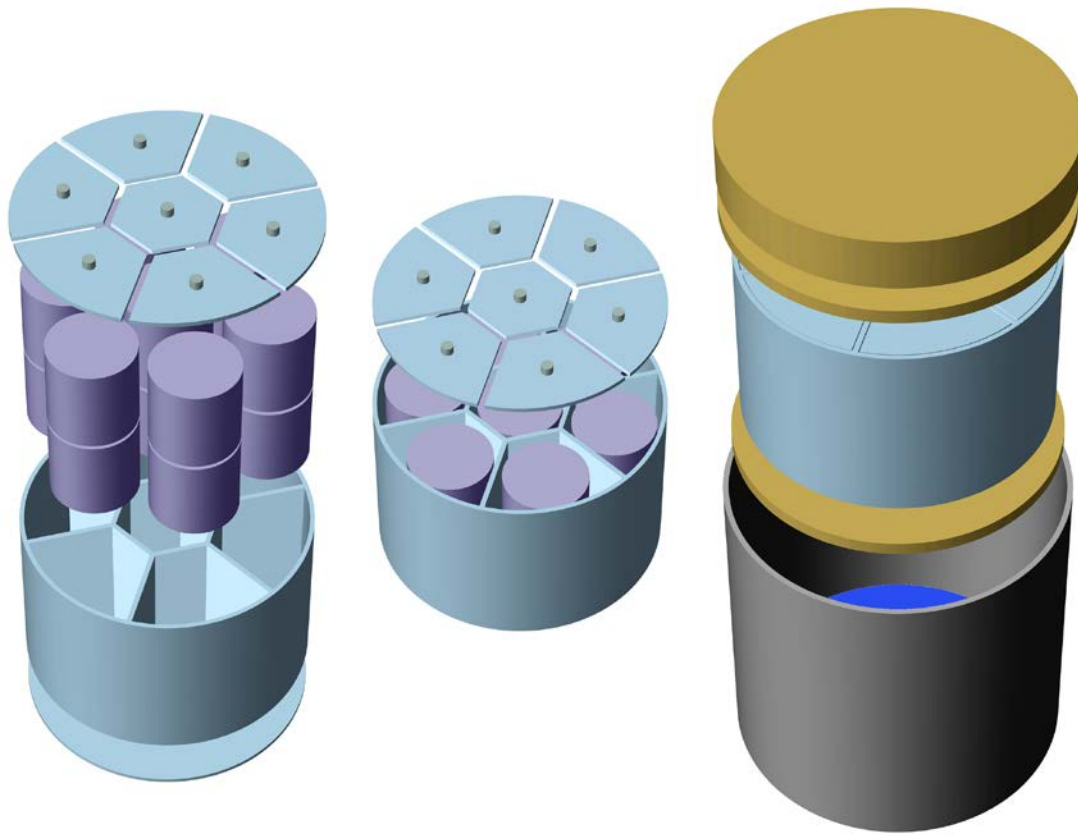

*Figure 20-25. Assembly of the component parts of the intermediate temperature storage system designed by Brian Wowk.*

The completed ITS system is shown in Alcor's patient-care bay in Figure 20-26. It uses a double-redundant system of heaters, temperature sensors, and controllers, and fills itself automatically from a dewar that is placed alongside. At the end of 2017, four neuropatients were maintained in this system.



*Figure 20-26. The dewar adapted for intermediate temperature storage stands beside a small dewar of liquid nitrogen in Alcor's patient care bay.*

The Wowk patent also includes designs for small portable ITS containers that can be held in the vapor space of unmodified dewars, and designs for containers and modified dewar vapor spaces large enough to hold whole body cryonics patients. Portable ITS containers for individual neuropatients have been built, but as of 2017 containers or modified dewars for ITS maintenance of whole body patients have not.

In 2003 a cryogenic engineer working with the Timeship initiative of the Life Extension Foundation designed and patented four new types of dewars specifically designed for ITS maintenance of whole body cryonics patients (US Patent 7299641). The most efficient designs consisted of a dewar within a dewar and had high capital costs but very low liquid nitrogen consumption. As of 2017, none of the designs had been built, although detailed drawings,

calculations, and construction cost estimates from a cryogenic engineering company exist in the custody of the Timeship project should there be sufficient interest and resources to pursue them.

It should be noted that to protect patients during transfers through warm room air, individual patient containers or pods for ITS tend to require more insulation than patient pods used for liquid nitrogen storage. Patients stored under liquid nitrogen will either be inside sleeping bags soaked with liquid nitrogen or inside neuro cannisters filled with liquid nitrogen that maintains patient temperature while boiling during transfers between dewars through room air. Patients at an ITS temperature do not have the protection of liquid nitrogen, and upon exposure to room air will begin warming at a rate determined by how well insulated they are. CT scanning of ITS patients in the cryopreserved state is problematic.

The ideal temperature for operating an ITS system for either cryonics or banking of vitrified organs in mainstream cryobiology is a complex and somewhat controversial question. The choice of temperature requires balancing risks of chemical change, ice growth, ice nucleation, and fracturing. Maintaining temperatures above  $T_g$  risks chemical change and especially ice growth. Maintaining temperatures near but below  $T_g$  risks ice nucleation, a time-progressive process by which water molecules reorganize into ice crystals of nanoscopic size that create hazards of freezing during later rewarming (see Section 19). Maintaining temperatures far below (15 or more Celsius degrees below)  $T_g$  mitigates the aforementioned risks, but makes at least some fracturing a practical certainty.

Determining the optimum balancing of these risks requires further research into specific slow cooling and annealing protocols for fracture avoidance, differential thermal contraction tendencies of different tissues, and ice nucleation rates as a function of temperature and cryoprotectant composition and concentration. If the conservative view is taken that time-dependent changes should be avoided as a matter of principle because we do not know how long cryonics patients will have to be maintained at low temperature, then as of 2017 no “safe” ITS temperature exists that will not result in at least some fracturing. ITS is therefore best currently regarded as a fracture *reduction* technology rather than fracture *avoidance* technology.

The capital costs per patient for ITS are greater than for conventional liquid nitrogen storage of the same scale. Although there are exceptions, such as the highly efficient dewar-within-a-dewar Timeship designs, liquid nitrogen consumption and costs also tend to be higher per patient. The capital and ongoing costs for neuro patients using the particular ITS system illustrated in this chapter are three times greater than liquid nitrogen storage in a Bigfoot dewar.

Hypothetically, suppose an ITS system reduces the average number of fracturing events from 20 to 10. We have no way of knowing whether this will be seen as significant from the point of view of molecular reconstruction efforts in the future.

While proven neuro ITS technologies are scheduled to be made available to the membership at Alcor soon, no such plans or resources currently exist for whole body ITS at Alcor. To remedy this “unequal” access to ITS, and to create a sensible transition period, Aschwin de Wolf proposed the idea of “Brain-Optimized Whole Body Cryopreservation” in which the cephalon of the patient is cryoprotected and stored separately in a neuro ITS unit. The whole body is either separately cryoprotected or straight frozen and stored in a conventional Bigfoot dewar or SuperD. An additional advantage of this option is that whole-body members can reap the advantages of isolated head cryopreservation without foregoing whole body cryopreservation.

Our summary, here, of ITS development is largely derived from a much longer and more thorough presentation by Brian Wowk: “Systems for Intermediate Temperature Storage for Fracture Reduction and Avoidance,” *Cryonics* 3rd Qtr. 2011, pages 7-14, archived on Alcor’s web site.

## **Equipment at the Cryonics Institute**

The Cryonics Institute has approximately 160 patients in long-term maintenance as of 2017, almost all of them whole bodies, as it does not offer an option for neuropreservation. The patients are at a facility in Clinton Township, Michigan, and the organization now claims to have a second nearby building which will be used for additional patients.

In 2009, the Cryonics Institute stated that it had ten cylindrical cryostats and three older, larger versions that are box-shaped. The designs were created by Andy Zawacki, who also fabricated many of them using fiberglass as the primary material. The cylindrical cryostats are now manufactured by an outside contractor.

Seven of the cylindrical cryostats are shown in figures 20-27 and 20-28 with a catwalk that is used for access. The largest box-shaped version is shown in Figure 20-29. Its vertical ribs are included to provide rigidity.



*Figure 20-27. Cryostats at the Cryonics Institute in Clinton Township, Michigan.*



*Figure 20-28. A catwalk allows access to the lids of the cryostats at the Cryonics Institute.*



*Figure 20-29. The largest of the cryostats at the Cryonics Institute. A vacuum pump stands on a small table at bottom-left.*

All the cryostats have an inner shell separated from the outer shell by a gap of about 12 inches. Vacuum pumps are used periodically to remove traces of air from the gap between the shells. According to the Cryonics Institute's web site, the pumps run on a schedule that varies depending which cryostat is involved. The most efficient, circular cryostat requires one or two 16-hour days of pumping every two months, while the least efficient, rectangular cryostat needs three days of pumping every two months.

The Cryonics Institute claims that its most efficient cryostat can attain a vacuum of 1 to 2 microns, while its least efficient cryostat gets down to about 20 microns. These numbers are attained immediately after vacuum pumps have been used.

The 12-inch gap between the inner and outer shell of each cryostat is loosely filled with perlite, a volcanic glass that normally contains 2 to 5 percent water. During the manufacturing process, perlite is heated rapidly above 870 degrees Celsius, causing the water in it to vaporize, forming tiny bubbles that cause the volume to increase by a factor of 7 to 16. The open cellular structure of dried perlite is a poor conductor of heat, and it blocks thermal radiation.

Patients are wrapped in sleeping bags, as at Alcor, but are not enclosed in pods. The cylindrical cryostats each contain 6 patients, oriented vertically, while the rectangular cryostats are in three sizes holding 7, 10, and 14 patients each, oriented horizontally.

Fiberglass designs have the advantage of being substantially cheaper than steel dewars, and may be almost as efficient, so long as vacuum pumps are used periodically. The Cryonics Institute claims an average cost of liquid nitrogen of less than \$100 per patient per year. The organization is fortunate to be located in an area where the cost of nitrogen is below the national average.

Liquid nitrogen deliveries are received on the same basis as at Alcor, except that the bulk storage tank in Michigan is located outside the building, as shown in Figure 20-30, and has a capacity of 3,000 gallons. The tank receives a delivery of about 2,000 gallons every two weeks. Nitrogen from the tank is then used to top off the box-shaped cryostats twice a week and cylindrical cryostats once a week, according to the Cryonics Institute web site.





*Figure 20-30. The 3,000-gallon bulk storage tank outside the Cryonics Institute.*

## **Vacuum Failure**

Dewars and cryostats may develop small leaks that allow air to penetrate their vacuum insulation. If this happens on a gradual basis, the first sign will be an increase in the boiloff rate. Alcor monitors boiloff on a regular basis.

Significant damage to the inner wall of a dewar or cryostat would be a much more serious matter, as nitrogen liquid would tend to be sucked into the insulation space, where it would vaporize rapidly. Gas pressure would then cause the inner wall to implode. Figure 20-31 shows a small dewar where the inner shell has ruptured in this way, although the cause remains unknown.

This type of failure will tend to wrap the inner wall around objects inside the dewar, making them difficult to remove.



*Figure 20-31. The interior of a small dewar after the interior shell has ruptured.*

A serious insulation failure that allows heat to reach the interior of a vessel can cause liquid nitrogen to boil violently, creating large volumes of vapor that escape from the vessel and create a risk of asphyxiation for anyone in the vicinity. For this reason, Alcor's patient care bay is fitted with oxygen sensors and multiple large ventilation ducts such as the one shown in Figure Figure 20-32, which has a diameter of 30 inches. If a sensor detects a falling level of oxygen, fans on the roof start immediately, and will draw air from

near the floor where nitrogen is most likely to accumulate. A trapdoor opens to allow fresh air to enter the facility from the roof.

The system has been tested by running the fans after increasing the humidity in the patient care bay and then allowing nitrogen vapor to create a dense white mist.



*Figure 20-32. One of several large ventilation ducts in Alcor's patient care bay. Fans on the roof are activated automatically if an oxygen sensor suggests a buildup of nitrogen in the air.*

Alcor owns a plasma cutter that may be used, in theory, like a can opener to get rapid access to a dewar, and Hugh Hixon believes that the volume of liquid nitrogen in a bigfoot dewar would take 12 hours to vaporize completely. He comments: “We could swap all the patients to another dewar within 30 minutes, so really it’s not an issue.”

If patients are stored in a SuperD dewar, Alcor plans to keep two bigfoot dewars in reserve as backup.

Neither Alcor nor the Cryonics Institute has ever reported a failure in a patient dewar or cryostat, as of the end of 2017. The relative safety of steel dewars vs. fiberglass cryostats remains an active but inconclusive debate.

## **Underground Storage**

Generally speaking, underground storage may be hazardous because it incurs a risk of contamination with groundwater that will freeze if it seeps in around the lid of a dewar. However, in Southern California, when Paul Wakfer founded a long-term maintenance company named CryoSpan, he felt that the risk of earthquake damage above ground outweighed the negative factors of placing patients underground. He was able to do this inside a facility, so that no protection from the weather was necessary.

Mark Connaughton assisted Wakfer by designing and building two silos, each consisting of a pit lined with prefabricated cylindrical sections of concrete. A heavily reinforced concrete platform was added by Connaughton around the mouths of the dewars (shown under construction in Figure 20-33). Patients were moved from another location to CryoSpan, and the photograph of Wakfer in Figure 20-33 was taken in 1996. After he ended his relationship with CryoSpan in 1999, the patients were moved to other cryonics organizations.

The silos still remain.



*Figure 20-33. Mark Connaughton in the process of constructing underground silos in Southern California for CryoSpan.*



*Figure 20-34. Paul Wakfer standing beside an underground dewar in one of the silos built at CryoSpan.*

## **The Cold-Room Concept**

During 1993 several people who had been actively involved in cryonics discussed the concept of a “cold room” that would be much like a walk-in cooler at a grocery store, except that cryonics patients would be lowered into it from above. The concept seemed attractive because it might enable intermediate-temperature storage more cheaply than using dewars, and if solid

blocks of insulation were used, they would eliminate the risk of vacuum failure.

Imagine a space 2 meters high, with a floor area 1 meter square. Suppose this is enclosed with blocks of insulation around all the walls, the ceiling, and the floor. If each block is a 1-meter cube, 34 blocks will be required, as shown on the left side of the exploded view in Figure 20-35, where layers of insulation for the ceiling and the floor have been separated to reveal the cavity in the center. Including the cavity, the cold room will occupy a total of 36 cubic meters, and available storage will be less than 6% of this total.

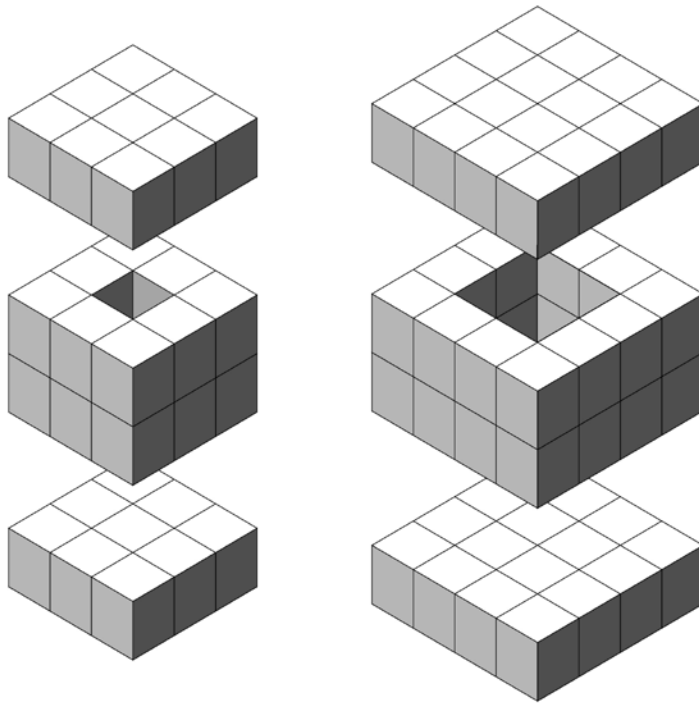
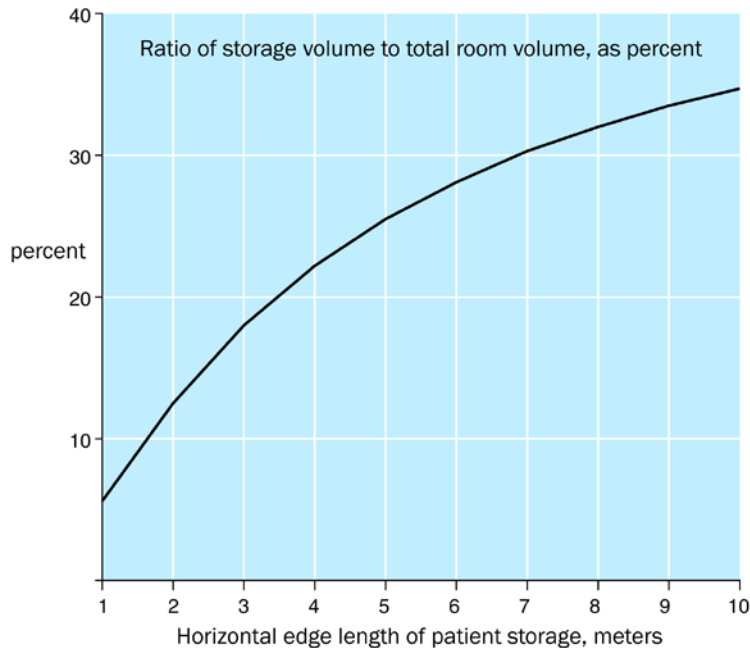

Figure 20-35. Assembly of blocks of insulation around a central volume of 1x1x2 meters (left) and 2x2x2 meters (right).

Now imagine the cold room enlarged so that the interior cavity is 2 x 2 x 2 meters, as on the right in Figure 20-34. The total volume of insulation will now be 58 cubic meters, while the interior allows 8 cubic meters of storage volume, which is about 12% of the total. As the horizontal linear dimension of a cold room increases, the percentage of the total volume allocated for storage

also increases, as shown in Figure 20-36. The efficiency in terms of materials cost per patient improves with the size of the room.



*Figure 20-36. In a hypothetical cold room, the percentage of the total volume that is available for interior storage increases as the dimensions of the room increase.*

Participants in the discussion suggested possible types of insulation and refrigerant that would enable intermediate-temperature storage. The concept appeared viable until a cryogenic engineer was consulted for his opinion and demonstrated that an array of bigfoot dewars would be no more expensive than a cold room, and would have the added advantage that the patients could be relocated to a different facility if necessary. Relocating patients from a cold room would be very difficult, and the concept was abandoned. It is included here in case the concept is proposed in the future by people who may be unaware that it has been explored in the past. The original discussion is stored online in the Cryonet archives.



## Very Large-Scale Patient Maintenance

Various plans and suggestions have been made for the maintenance of very large numbers of patients at a hypothetical time in the future when the concept of cryonics achieves wider acceptance. The Timeship project, funded by Life Extension Foundation and coordinated by architect Steven Valentine, proposes to enclose patients in pods that are assembled in “neighborhoods” cooled by nitrogen vapor. Multiple neighborhoods would then be assembled to form “communities.” A neighborhood and a community are shown in an architect’s model in Figure 20-37.

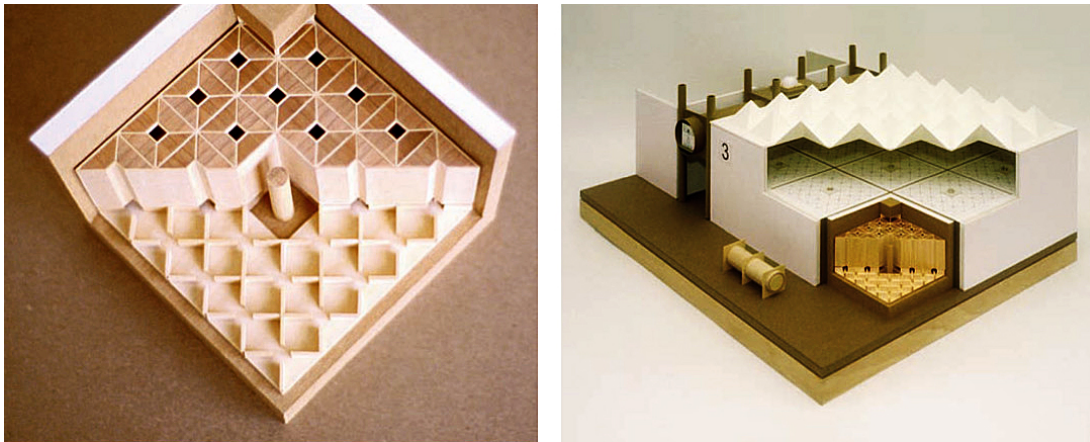

*Figure 20-37. Patient pods arrayed in a “neighborhood” of the Timeship building (left), while the neighborhood is shown in a “community” (right). The Timeship project would contain multiple communities.*

Land for Timeship has been purchased in Texas, in a location where there is minimal risk of flooding, tornadoes, earthquakes, and other natural disasters. Construction of the building has not begun.

In the July 2014 issue of *Cryonics* magazine, Ralph Merkle presented a thought experiment for the cryopreservation and long-term maintenance of millions of cryonics patients. Inspired by huge natural-gas storage facilities such as the 250,000 kiloliter underground tank in Yokohama shown in Figure 20-38, Merkle imagined it containing liquid nitrogen instead of liquified gas, and calculated that 5.5 million neuropatients could fit into a sphere with a

radius of 30 meters. He suggested that with these economies of scale, operating costs in this “big picture” could be \$1 per person per year, or even less.



*Figure 20-38. A 250,000-kiloliter liquefied natural gas storage facility under construction in Yokohama.*

Thought experiments of this type are a useful antidote to conservative bias, but cryonics has often tended to err in the opposite direction. The field has an unfortunate history of underrating the complexity and expense of ambitious ideas. In particular, ever since Robert Nelson toured cryonics conferences in the late 1960s showing renderings of a cryonics facility that did not actually exist, cryonicists have been easily seduced by the concept of very large facilities for patient maintenance.

Activists in cryonics can feel proud of some remarkable achievements since the freezing of Dr. James Bedford more than fifty years ago, most notably the development of cryopreservation procedures described in this book. The work has been done with minimal funding by a relatively small number of dedicated activists. They have persevered in the face of universal skepticism and frequent hostility because they share an ethically driven belief that death is a terrible enemy of all decent people. For those who see the urgent need to develop and deliver better cryopreservation under conditions that are sometimes extremely challenging, big pictures can either be an inspiration or an unwelcome distraction.

# **My Background in Cryonics**

**by Charles Platt**

I encountered the realities of death when I was about 12 years old. My great-aunt had died unexpectedly of a heart attack, and I found myself at her funeral, surrounded by adults who expressed sadness but resignation. After a minister tried to ease everyone's pain by assuring us that our loved one had made a transition to the hereafter, we went home to continue our lives.

For me, it was not so simple. My great-aunt had been a sweet-natured, gentle woman who used to enthrall me with stories of her travels through colonial Africa. She had ridden elephants; she had cooked meals over a camp fire in the wilderness; she had killed poisonous spiders in her tent. I could not resign myself to the sudden loss of such a unique person, with all her traits and memories.

I was angry that other people seemed so complacent about mortality. When I expressed my anger, other people became angry with me. They told me I should stop "being morbid" and learn to enjoy life.

Well, I did enjoy my life. I saw my own mortality as a source of regret, but not of fear. What bothered me was that so long as I lived, I would have to deal with the pain of losing other people whom I loved.

## *Taking the Tour*

In 1988, when I was 43 years old, I found an opportunity to tap the power of my anger about death and direct it usefully. My friend Gregory Benford, a plasma physicist and science-fiction writer, was attending an academic conference in Riverside, California. With him was Joe Haldeman, another science-fiction writer. Haldeman had heard that there was a cryonics

organization in Riverside named Alcor Foundation, and he found it listed the phone book. Someone at Alcor agreed that a couple of science-fiction writers would be welcome, so Benford and Haldeman took time away from their conference for a quick visit.

A few days later, Benford told me about it on the phone, sounding impressed by what he had seen. "I really think they may be on to something," he said.

I was skeptical, but I was also intrigued, so I contacted Ed Ferman, the editor of *The Magazine of Fantasy & Science Fiction*. I asked him if I could write an article about Alcor, and he agreed.

My tour of the facility was conducted by Alcor's then-president, Michael Darwin, who seemed just as angry about death as I was, but much better informed. I asked every conceivable question, and received answers that I found logically impregnable. I concluded that under ideal circumstances, after plausible developments in nanotechnology, revival from cryopreservation could occur. The only remaining question in my mind was the chance of success for me if I signed up for the procedure.

I considered the biological and engineering problems that still had to be overcome. I also reviewed the uncontrollable factors that could interfere, such as bankruptcy or hostile takeover of the cryonics organization, general socioeconomic collapse, devastation caused by warfare, legislation that might outlaw cryonics or make it prohibitively expensive, or equipment failure. There was also the possibility of dying in such a way that I might be undiscovered until irreversible brain damage had occurred. Adding it all up, I guessed that the chance of a cryopatient being revived in the future might be about 1 in 10,000.

These odds were unattractive. However, as cryonicists always like to say, the alternative was worse.

A few weeks later, I sent Alcor \$20 for an associate membership. It took me quite a while to take the next step, but eventually I obtained a whole-life insurance policy and executed cryopreservation documents.

### *Improving the Odds*

Now that I had committed myself, I was motivated to do anything that might improve my odds. An important factor was the financial security of Alcor, and one way to strengthen the organization would be by encouraging membership growth.

In my primary occupation as a writer, I had contributed a couple of articles to *Omni* magazine. This seemed an ideal place to publicize cryonics, so In 1991 I wrote a one-page opinion piece for *Omni* titled “Confessions of a Cryonicist,” describing my own decision to sign up. At the bottom of the page, I included Alcor’s 800 number.

I was told that this short column stimulated more information requests than any other single piece of publicity that Alcor had received over the years. I soon received a phone call from legendary activist Saul Kent, who wanted to find out how useful I could be in promoting cryonics in the future. He passed my phone number to Brenda Peters, who was in New York City, where I was living at the time. Brenda called me, and I became acquainted with her and her husband Courney Smith. They were running the New York chapter of Alcor at that time.

We discussed many approaches to the general problem of rousing serious interest in cryonics. My piece in *Omni* had only worked because of what Saul Kent described accurately as “the power of a testimonial.” I didn’t think I would be so effective if I wrote another testimonial for another magazine, so I had to think of something new.

### *Giving It Away*

Contests are a basic tool in PR. Automobile companies give away free cars on game shows; why couldn’t Alcor give away a free freeze? I sensed that it would attract a lot of publicity, as it would be the first contest of its kind.

After a board meeting, Alcor approved the idea in principle, so I went back to *Omni*, which I still considered the ideal market, with its paid

circulation approaching 1 million. I suggested that they could sponsor the contest as a cover feature. My editor agreed, but only if he didn't have to pay anything toward the cost of the prize. After some negotiation, Alcor agreed to do it on condition that *Omni* would give them a couple of complimentary full-page ads.

I wrote an article promoting the contest, and I wrote and designed the free ads. The contest attracted the publicity that I had expected, including many interviews for me on talk radio and an hour on a nationally networked TV show. The PR department at *Omni* estimated that one way or another, the existence of the contest was communicated to around 30 million people.

To enter the contest, the only requirement was to write a one-page essay explaining why a person would like to be cryopreserved in the hope of future life. This was a chance at biological immortality. It might not be a large chance, but it was certainly greater than zero, and it was available for the cost of a piece of paper, an envelope, and a postage stamp. (This was before the ubiquity of email.)

We received slightly more than 300 entries. If *Omni's* estimate of audience penetration was correct, about 1 person in 100,000—that is, 0.001 percent—had felt it was worth their while. Evidently, cryonics was such a hard sell, most people weren't interested even if we tried to give it away.

News media loved cryonics, because the concept was an attention-getter. But the vast majority of the population was not willing to take it seriously.

Around this time, I remember explaining the basics of cryonics to another science-fiction writer, Barry Malzberg, when we were eating lunch together in a New York deli. Barry became so agitated, he didn't finish his sandwich. "You're like a company selling tickets for a rocket to Mars," he said. "But you don't even know how to get there!" He paused, thinking it through. "But it's worse than that. You don't even know how to build the rocket!" He thought some more. "No, it's even worse than that! You don't even know anyone else who knows how to build the rocket. You're hoping that someone in the future will figure out how to do it."

This was basically correct. The difference between myself and Barry was that I felt that defeating mortality was so important, it justified some risk, so

long as the organizations offering the service were entirely open about the procedure.

I suspected that most people didn't see it my way. They were more likely to share Barry's outlook, and I didn't know how to convince them to change their minds.

### *We Don't Have Anyone Else*

Saul Kent had put in his own time trying to promote cryonics for many years before me, and had reached the conclusion that his efforts were unproductive. He concluded that the right approach was to improve procedures to the point where the plausibility of cryonics became self-evident. Then, people would be interested in it. With this in mind, he had started to invest large sums in research.

I didn't have the money to do that, but I had some free time, so I started helping out with cases. By 1995 I understood all the procedures and was well acquainted with almost all the principal activists, and when CryoCare Foundation was created as a spinoff from Alcor, I served as its vice-president for three years before eventually becoming its president.

Meanwhile, in my professional life as a journalist, I had become one of three senior writers for *Wired* magazine. When this work ended in 2001, I was left wondering what to do with myself. CryoCare had gone out of business after its key service provider quit, so I reinstated my membership in Alcor. I had relocated in northern Arizona, so I began visiting the Alcor facility and serving as the photographer in their operating room.

I suggested to Jerry Lemler, the new CEO of Alcor, that I could update some of their printed materials. He told me that there was a much more pressing need, for a new team leader in standby-transport work. When I protested that I had no applicable experience or qualifications, Jerry pointed out that I had already participated in cases and was knowledgeable about the procedures. He then made the clinching argument that I have heard many



times in cryonics: “We really need you to help us, because we don’t have anyone else.”

During the next six months, as Director of Cryopreservation Services, I ran five cases, restocked Alcor’s standby kits, planned a buildout of the facility, repaired Alcor’s relationship with its UK members, purchased a new transport vehicle and planned its conversion, and (most important) revitalized the volunteer network that I regarded as essential. In 2003 I organized the largest training session in Alcor’s history, which lasted for five days and attracted more than 30 people.

One of those people was Aschwin de Wolf.

### *Suspended Animation*

Doing cases for Alcor was extremely stressful. After six months, I was exhausted, I was coming down with persistent virus infections, and my PSA score was up to 11. Evidently, my immune system was not doing well. Saul Kent suggested that if I wanted something easier to do, I could visit Florida to evaluate the situation at Suspended Animation, Inc, a standby-transport organization that had been established by David Hayes and David Shumaker. They had been capitalized with slightly more than \$2 million by Life Extension Foundation in the hope that a for-profit company devoted solely to standby-transport work would achieve better, more consistent results than a full-service cryonics organization that had to divide its time and money among multiple activities.

I visited SA and found it on the brink of collapse. Buildout work had been halted halfway to completion, because the local government in Boca Raton had refused to issue any permits. The company had no legal right to occupy the building, and could be evicted at any time. Animal-rights activists had targeted SA because a single sentence in the company’s business plan mentioned research involving rodents. There was nowhere else for the company to go; when I visited regulatory officers in neighboring communities, I found that all of them were familiar with SA and hostile to the idea of it invading their territory.

Still, I have always enjoyed a challenge. Life Extension Foundation named me as the new general manager of SA. I loaded all my most important possessions on a pickup truck and drove from my home in Arizona, through the eye of hurricane Ivan, and thence to Boca Raton.

Hayes and Shumaker left the company, so my most urgent need was for someone to work with me. I contacted Aschwin de Wolf and paid his air fare to visit me. After a couple of days to familiarize himself with the situation, he remarked thoughtfully, "This is much worse than I had expected."

I waited, feeling extremely anxious.

"I can see I will have to get involved," Aschwin concluded.

During the next two years, we relocated the organization to the neighboring town of Boynton Beach, established a handshake relationship with the mayor, received our permits, went through a \$200,000 renovation-and-buildout, hired new employees, and started designing and fabricating new equipment. Aschwin, meanwhile, proceeded to educate himself in every aspect of cryonics. He spent months reading every possible source, and acquired the more formal medical and biochemical knowledge that I lacked.

### *Prototyping in Southern California*

By the end of a second year in Florida, I had built a prototype of a liquid ventilation device to achieve rapid cooling of the body by infusing chilled perfluorocarbon liquid in the lungs. This device was tested successfully at a lab in California funded by Life Extension Foundation.

I moved to California to continue the development of liquid ventilation. Saul Kent set me up in a dream job for anyone who has ever imagined doing prototype development: I had my own space in an industrial park where I could design and build anything I wanted. I was assisted by Todd Huffman (who later pursued exciting research at his own company, 3Scan) and Piotr Ruc, a master welder whom I had hired at SA. I could design a component in the morning, and Piotr would have it beautifully fabricated in stainless steel by the end of the afternoon.

This was a hugely creative period, and some of the results are described in this book. Only one thing was wrong: I was now living in the greater Los Angeles area. By the end of 2007 I was desperate to get back to my home in Arizona, so Saul Kent agreed that I could continue the liquid ventilation work there. I paid for the construction of a new building with a workshop into which I moved all my equipment. I then designed and built one more iteration of the liquid ventilation system, which is still in use at the time of writing.

### *No Outcome*

Life Extension Foundation had been my patrons for four amazing years, enabling a range of work that I would never have been able to do elsewhere. In the end, though, I realized that I am still a writer by nature. Managing cryonics cases, rescuing a startup business, and prototyping equipment were tasks that I could perform with some success, but I still wanted to write books.

I also saw a more serious problem. I had worked as hard as I could in almost all areas of cryonics, but some of my decisions had been unfortunate (in hiring personnel, especially) and my successes were beginning to seem transient. The standby capability that had been restored at Alcor was already deteriorating. Several of the volunteers who had helped me with great dedication, and had turned difficult cases into successes, had drifted away. Meanwhile, at SA, I no longer felt entirely confident about the future of their standby-transport capability.

The root problem was, and still is, that standby-transport work is expensive, stressful, and unrewarding. Funding it is always a struggle, and the people who do the work tend to become exhausted. Eventually they devote their time to other things.

Also, as my one-time mentor Michael Darwin has mentioned many times, there is no perceived outcome of a cryonics case. A patient who has received prompt intervention, rapid cooling, quick transport, and excellent cryoprotective perfusion ends up immersed in liquid nitrogen alongside a less fortunate person who suffered terrible ischemic injury and could not be perfused at all. And because there is no perceived outcome, we have no easy

way to tell them apart. To some extent this problem is being addressed now by the wonderful development of doing CT scans of cryopreserved neuro patients, but being able to see areas that are ice-free is not the same as feeling confident that those areas can resume their function.

In orthodox medicine, heroic efforts are validated when a patient is rescued from a terrible accident or a terminal condition and becomes healthy again. In cryonics, we lack this positive reinforcement. We are unlikely to know if our work has really been worthwhile until revival is attempted, maybe 100 years or more from now. Consequently, rapid intervention never seems as important as it really is, and maintaining the capability is always a challenge.

### *Unfinished Business*

In 2010, I made my own personal assessment and decided that I had failed in my original goal of raising the perceived odds of revival above 1 in 10,000. This was an entirely subjective evaluation, and other people may have a very different view. But if I couldn't demonstrate to myself that I was making a tangible and permanent difference, I lacked the motivation to continue, especially as a lot of work in cryonics tends to be a taxing experience. In the memorable words of Ben Best, former president of The Cryonics Institute: "Running a cryonics organization is like standing in a rain of hammers."

I returned to my primary occupation, and started writing books about electronics, one of which turned out to be very successful. Being a freelance writer is a notoriously risky occupation, but it is an order of magnitude easier for me than doing cryonics case work.

One piece of unfinished business still remained for me in cryonics. Because all organizations tend to have immediate priorities, the longer-term task of writing standard operating procedures tends to be overlooked, and knowledge tends to be lost. I felt I had acquired a lot of knowledge during my decades in the field. I had also done interviews with most of the important figures (for a book that was never completed). I had participated in more than 20 cases, and generated many designs for equipment. I didn't want this experience to disappear.

My friend Aschwin seemed to feel the same way, and when we expressed an interest in doing something about it, we were encouraged by Alcor director Brian Wowk. Life Extension Foundation decided to underwrite our effort, so Alcor issued a contract for Aschwin and myself to write this book.

This has taken much, much longer than planned, but finally we have done what we set out to do.

### *Death Is Not Inevitable*

In broad, general terms, this book describes how human cryopreservation was done at the end of the twentieth century and the beginning of the twenty-first. It is not as detailed as a standby-transport manual, but provides an overview which may be helpful to anyone who is interested in participating in cryonics as a full-time or part-time employee, or as a volunteer.

I believe Saul Kent was correct when he told me in 1993 that the key to finding widespread acceptance for cryonics is to improve procedures to the point where their plausibility becomes self-evident. I don't believe this will be achieved in my lifetime, but that doesn't negate the importance of the effort.

I am proud to have been a part of it, because I can think of no activity more meaningful, more ethical, and more necessary. I still feel angry when I think about the idea that was imposed upon me when I was 12 years old, that I should accept the inevitability of death. I may not live to see the ultimate fruition of the efforts expended by my friends and myself in this field, but if we have done even a small amount to promote the idea of cryonics and facilitate its future success, I consider it all worthwhile.

Now I must give thanks to the sometimes difficult but always immensely special people who have given me so much help along the way. In approximately historical sequence, these 41 names mean a lot to me:

Gregory Benford  
Michael Darwin  
Curtis Henderson

Brenda Peters  
Linda Chamberlain  
Fred Chamberlain  
Brian Wowk  
Gregory Fahy  
Hugh Hixon  
Mike Perry  
Courtney Smith  
Kevin Brown  
Ralph Whelan  
Jim Glennie  
Cairn Idun  
Steve Harris MD  
Joan O'Farrell  
Sandra Russell  
David Pascal  
Ben Best  
Andy Zawacki  
Jim Yount  
Paul Wakfer  
David Pizer  
John Grigg  
Alan Sinclair  
Michael Riskin  
Jerry Lemler  
Bobby June  
Peter Voss  
Joe Waynick  
Joe Hovey  
Jerry Searcey  
Todd Huffman  
Todd Soard  
David Hayes  
David Shumaker

Kelly Kingston

Piotr Ruc

Max More

Steve Graber

But most of all I thank Saul Kent and Bill Faloon. Without their fearlessness, intransigence, and business acumen, cryonics as we know it would not exist.

If some of the people named above are revived in the future, I may not be there. But perhaps this book will be. A writer can ask for nothing more than that.

Charles Platt

Northern Arizona

2019

## **Afterword by Aschwin de Wolf**

In 2002 I made whole-body cryopreservation arrangements with Alcor. It seemed evident to me that cryonics was a field that would benefit from informed, active, member involvement. Not one to sit idle on the sidelines, I welcomed the opportunity to participate in a week-long cryonics training at a retreat in Arizona during 2003.

I am not sure if I would be writing an introduction to this manual today if I had not attended this event because it allowed me to interact with Charles Platt, the organizer of the meeting and co-author of this manual. I cannot claim that I understood the rationale or details of all the procedures that we were taught (one must remember that these were the days when volunteers were taught how use an air-portable perfusion circuit to conduct field blood washout) but I must have made enough of an impression on Charles for him to consider me a potential staff member when he was tasked with re-booting the cryonics service provider Suspended Animation in 2004. In the summer of 2004 I moved to Florida to be employed in cryonics.

When I started working at Suspended Animation the organization did not have detailed contracts in place to perform stabilization procedures for the major cryonics organizations. Consequently, the emphasis was mostly on development of cryonics response capabilities and staff education. What does education entail in a cryonics organization? Unlike in general medicine, one cannot just pick up a “cryonics textbook” and attend classes for the practical stuff, at least not in the commonly understood meaning of those words. So, I studied old Alcor procedures manuals, training manuals, Ben Best’s online cryonics writings, and engaged in extensive conversations with Michael Darwin and noted cryobiologists to deepen and refine my knowledge.

Another situation that favored (or I should say, forced) me to familiarize myself with all pertinent scientific, technical, and logistical issues of cryonics was the addition and departure of staff members at Suspended Animation. In a relatively short period of time I had to familiarize myself with topics as



diverse as standby kit contents and maintenance, medications documentation, extracorporeal circuit design, and mixing organ preservation- and vitrification solutions.

There is a thin line between internal documentation and publication and soon I found myself writing articles about cryonics procedures for cryonics magazines and websites. I often used these public articles as exercises to articulate the current state of knowledge about a topic or identify areas where more research and development is necessary. I did not claim (and still do not claim) to be an “expert” in these areas but the extensive research and writing involved primed me well for collaborating on a manual such as the one you are reading now.

In 2007, I moved to Phoenix, Arizona and become further involved in Alcor’s operations while still doing contract work for Suspended Animation. One proposal under discussion with Suspended Animation was the writing of a comprehensive procedures manual. When an Alcor official heard about this potential project, Charles Platt and I were approached to submit a detailed proposal for Alcor instead.

Work on the manual started in 2008 and has gone through periods of rapid, focused activity, and periods of slumber, depending on other obligations of the authors and the Editor. What kept all of us motivated is the recognition that there is no up-to-date comprehensive cryonics procedures manual and topics such as vitrification, cryoprotectant circuit design, and long-term maintenance have not been documented in manual form at all. Its history and methods could only be reconstructed through detailed study of in-house SOP’s so there is clear need a manual such as this. *Human Cryopreservation Procedures* aims to provide the rationale, history, and technical aspects of Alcor’s operations, with some references also to Cryonics Institute.

With a project of this scope it is important to articulate what it is and what it not is. While this manual delves into the scientific rationale of cryonics procedures more extensively than the older Alcor training manuals, these issues are often only discussed to provide enough contact to effectively communicate and monitor them. For example, you will not find technical reviews of the molecular mechanism of cryoprotectant toxicity. You will also not find specific tubing assembly specifications, or how prevent contamination

of in-house mixed perfusates. As such, this manual is a bridge between scientific research that provides the rationale for cryonics and detailed SOP's to implement the procedures documented in this book.

We do not claim to cover every conceivable procedure in detail. Our general approach has been to divide the labor between us based on how comfortable one of us felt in drafting a specific chapter. There are chapters where one of us was specifically involved in developing the technologies in question and others where one of us just happened to have a stronger interest in the topic. The results have been further fact-checked by researchers and practitioners of cryonics, under the supervision of a highly-knowledge and experienced Editor. We aim for this manual to be an Alcor-supervised project that continues to be revised and expanded when new facts are uncovered, or technologies are changed.

Most cryonics procedures and training manuals were written before the rise of the Internet or when this technology was still in its infancy. As a result, these manuals are now archived as historical materials on the Alcor website. In the case of our manual we aim to create a dynamic online document which will be modified, expanded, or corrected as new technologies are introduced or new information becomes available. As such we hope that our manual will become a resource for exiting and future Alcor staff members and educated members.

When I accepted the assignment to co-write this manual I had one concern, and upon completion of the project it is important to articulate it: There is still a wide gap between the quality of cryopreservation that can be achieved in the lab and what we can reasonably expect in a typical cryonics case. What sets this manual apart from some similar efforts in the past is that there are many sections in which we discuss emerging technologies and protocols to further close the gap between the ideal of medical biostasis and current Alcor procedures. Closing that gap and seeking continuous improvement in the delivery of cryonics services is only possible if the organization implements a comprehensive data collection and quality control program. To advance this goal this manual includes two additional appendices on the writing of case reports and quality control in cryonics. Only if Alcor (or any credible cryonics organization) implements most of the suggestions

contained in these documents and creates an internal culture where curiosity, feedback and excellence is nurtured, will it be possible to fully benefit from the information in this manual.

Aschwin de Wolf

2019

# **Appendix 1**

## **Quality of Patient Care in Cryonics: A Systematic Approach**

### **Introduction**

The term “patient care” requires little explanation in mainstream medicine. When a patient is admitted to a hospital for a routine medical procedure there is usually an obvious expectation of what the desired outcome should be – even to people without a medical background. The hospital employs qualified personnel to ensure that the intended procedure conforms to protocol, and medical practice and internal and external entities make sure that good practices are adhered to.

In cryonics, however, a common belief is that the only meaningful test of efficacy of a cryonics procedure is whether the patient is revived in the future. In the most fundamental sense this is correct, but framing the issue of quality care in cryonics this way obscures the fact that cryonics consists of several specific procedures that are aimed at a specific outcome for which data can be collected to evaluate how well the delivery of this procedure conformed to its stated objective.

In this document we will propose a general framework to evaluate patient care in cryonics, translate these objectives into distinct objectives for each major procedure, and discuss its physical, logistical, educational, and staffing implications.

### **Long Term Care**

Alcor’s mission statement states that maintaining “the current patients in biostasis” as its first and fundamental goal. This objective is so fundamental that it could potentially conflict with placing new patients in biostasis or conducting research to improve cryopreservation procedures. Since this fundamental goal pertains to patients already in biostasis it is no longer possible to improve their (physical) condition relative to the time when they were placed in liquid nitrogen. One recent caveat to this observation concerns Alcor patient’s that are currently stored at intermediate temperatures (ITS). Poor maintenance and anticipation of future ITS needs could result in additional fracturing if those patients are placed in regular liquid nitrogen dewars.

In a general sense, however, providing good patient care in the case of long term care means maintaining patients at cryogenic temperatures. This objective does not mean a “passive” continuation of existing physical storage arrangements. For example, dewars are expected to have a finite lifespan and money will need to be set aside for future changes. New dewars can be designed to reduce liquid nitrogen boil off and reduce the cost of long-term patient care (for example, the gradual replacement of the Bigfoot dewars by Alcor’s Super dewars). Alternative storage options and emergency procedures will need to be drafted in case manufacturers and suppliers no longer want or can deliver storage vessels to Alcor. Alternative storage locations need to be considered in case there are political or economical reasons for abandoning the current storage facility.

Two important measures to ensure Alcor can deliver on its most fundamental mandate include the creation of a legally and financially separate patient care trust and the creation of a full-time patient care taker. The care trust ensures that patients will be shielded from the day-to-day organizational and financial challenges of a membership and service delivery organization. The full-time patient caretaker's sole responsibility is to maintain the patient's in cryostasis, documentation, and report to the cryonics organization (and its care trust) on potential developments that can reduce the cost and enhance the safety of Alcor patients.

## **Cryopreservation**

The common denominator of all Alcor patents is that they are cryopreserved. But the variable that matters for evaluating the quality of care is how well they have been *cryoprotected*. For a patient the degree of ice formation can range from a straight freeze (cryopreservation without cryoprotection) to complete vitrification (solidification without ice formation). Elimination of ice formation (or minimization of ice formation in whole body patients) is a minimal requirement of Alcor's cryopreservation protocols but it by no means exhausts its mandate.

It is important to distinguish here between Alcor's long-term research objective and what is possible with current technologies. Alcor's long-term objective is to develop (or implement) reversible cryopreservation, or human suspended animation. Reversible cryopreservation would allow a critically ill patient to be placed in biostasis without causing any further damage that was not reversible by contemporary means. Alcor's research goal is to conduct or collaborate on research to narrow the gap between human suspended animation and its current cryopreservation capabilities.

What we should require from a cryopreservation protocol evolves and is based on reasonable extrapolations from contemporary cryobiology research. At the time of writing we should expect cryoprotection of the patient with a vitrification solution that can (a) eliminate ice formation at realistic cooling rates, (b) preserve the fine structure of the brain, and (c) recover some viability in cryopreserved isolated brain slices as a marker of minimal biochemical disturbance.

Elimination of ice formation can be assessed by subjecting (neuro) patients to CT scans. Preservation of the fine structure of the brain can be assessed by obtaining microliter samples of the patient's brain for electron microscopy. These brain samples can also be subjected to viability assays such as the K/Na ratio assay. It is important to recognize here that our current understanding is that elimination of ice formation and preservation of the fine structure of the brain is possible but that obtaining high viability readings from brain samples of patient's is not yet within our reach. Our current belief is that in very good cases viability of the brain is lost during the early to mid-stages of cryoprotective perfusion because of cryoprotectant toxicity and CPA-induced dehydration of the brain. This means that for a typical cryonics case conducted under good condition we should collect evidence that we achieved the first two objectives (vitrification and ultrastructural preservation) and support research and development aimed at maintaining viability throughout the whole cryoprotection procedure by further reducing cryoprotectant toxicity, eliminating CPA-induced brain shrinking, and optimization of cryoprotection protocols. At this point each case report should contain CT scans and electron

micrographs to document the degree of vitrification and ultrastructural preservation achieved in a (neuro) patient, if applicable.

### **Stabilization**

As the word “stabilization” suggests, the aim of this set of cryonics procedures is to stabilize the condition of the patient from the moment of pronouncement of legal death. That means that, ideally, there will be no further deterioration to the patient’s physiological functioning and condition of the brain. Since cryonics procedures can only start after pronouncement of legal death, the initial (pre-mortem) state of the patient is usually beyond the cryonics organization’s control. It is important to recognize this because proper evaluation of casework should describe this initial state as its benchmark.

In a good cryonics case, where the patient has not been diagnosed as brain death, and where response can be begun promptly, the objective of stabilization procedures is to keep the brain viable by *contemporary* medical criteria. One helpful way to describe this mandate is that upon completion of stabilization procedures it should be possible to *reverse* those procedures and recover brain function.

Keeping the brain viable by contemporary medical criteria is something that cannot be measured in a straightforward matter because at the completion of stabilization procedures the temperature of the brain is not able to support meaningful whole brain function. What can be done is to take microliter brain biopsies and subject these tissue samples to viability measurements. These measurements in turn can be compared to brain biopsies obtained after the completion of cryoprotective perfusion to understand how cryoprotection affects viability. The sample samples can subsequently be processed for electron microscopy to obtain information about the ultrastructure of the patient’s brain.

Another means to ensure that stabilization procedures are successful in keeping the patient viable is to collect blood samples (pH, electrolytes etc.) and end tidal CO<sub>2</sub> readings throughout the procedure. Collecting temperature data during all parts of cryonics procedures is essential because the temperature profile of a patient is a reasonably good indirect measure of brain injury (or lack thereof). Each patient case report should include a presentation of monitoring data and discuss the reason for not being able collect some of this information if this occurred.

### **Readiness and Deployment**

Since its inception it has been routine in cryonics to document stabilization and cryopreservation procedures. When it comes to readiness and deployment, however, policies have often changed from administration to administration - if documented policies existed at all. Since a cryonics organization’s state of readiness and deployment policies have profound effects on its ability to timely respond to a patient and the quality of care a patient will receive, a credible quality control – and assurance program should be extended to readiness and deployment as well.

Some of the questions that need to be addressed include: who is responsible for local and non-local cases? What are the conditions for deploying a local or remote team? What is the composition of a deployment committee and should all parties have equal say in deployment

decision (such as for-profit independent contractors)? What is the minimum number of team members required to do the full stabilization protocol? What is the likelihood of having multiple deployments and cases at the same time? What is the role of local (volunteer) teams? Should complete sets of standby kits be deployed to local groups with a lot of members? What makes a region eligible for respectively a cryonics first aid kit or a full set of kits? Which procedures should be only be done by medical professionals and which procedures can be done by all trained individuals?

When a cryonics organization answers these questions and incorporates them in a set of policies and protocols, then a formal quality control program will have a framework to evaluate the state of readiness at a cryonics organization, and thus the ability to respond to cases in a consistent and reliable manner.

## **Training**

Like readiness and deployment policies, the training of volunteers and medical professionals can greatly benefit from a set of formal policies, eligibility criteria, and written teaching materials. A review of the history of cryonics training at Alcor reveals a plethora of different approaches ranging from the teaching of members and volunteers to do the most advanced procedures (i.e. surgery, whole body blood washout) to not providing any training at all to non-professionals. A detailed review of cryonics training options and curricula is beyond the scope of this manual, but we want to make a few observations.

The transition from a volunteer-driven standby to employing team made up of medical professionals does not eliminate the need for providing cryonics training. While medical professionals may be certified and competent to do a specific cryonics procedure (surgery, extracorporeal perfusion, IV placement) they may not be familiar with other aspects of our procedures, or how specific procedures work together to produce a specific outcome. It is therefore important for Alcor (or its contractors) to organize periodical cryonics training courses and to provide relevant reading materials and updates.

A second reason why the use of professionals in cryonics does not exempt a cryonics organization from conducting training is that there will still be cases in which the professional standby organizations will not or cannot deploy a standby a team in time. Such a situation does not necessarily indicate poor readiness at the standby organization but can also reflect a rapid decline of the patient or challenges to get to the patient in time due to weather or logistical obstacles. In these circumstances local members and volunteers may have do the initial or all parts of a cryonics stabilization. Teaching local members basic cryonics “first aid” protocols and how to assist a professional standby team is essential for a cryonics organization that covers a country as large as the United States, not to speak of other countries.

It is increasingly recognized in cryonics that using members/volunteers and medical professionals is not mutually exclusive and the nature of cryonics today necessitates a model in which local volunteers cooperate, complement, or sometimes even replace a professional standby team. This “hybrid” model of standby implies that a cryonics organization creates different levels of protocols and training curricula. A proper quality control- and assurance program in cryonics

needs to address both the local / volunteer part of cryonics as well as overseeing the use of medical professionals.

## **Staffing**

The staffing of a cryonics organization is a complex topic and we confine ourselves here to making some observations pertaining to the quality of case work and quality control. Currently, Alcor's financial situation allows for the deployment of staff with a medical or scientific background. It is important that the core of Alcor's (local) standby team is made up of at least two individuals with a strong EMS, nursing, or scientific background. When these individuals are a part of Alcor's staff, case work is always a priority and complex coordination of volunteers and contractors is reduced. These staff members should take a leading role in standby equipment maintenance, team composition and deployment, training, standbys and the collection and gathering of case data. In a cryonics organization with a high case load it is important that these individuals are not distracted from these responsibilities by other responsibilities such as extensive writing tasks like case reports.

When generous funding is available in cryonics it is tempting to "recruit" competent staff members to work for (for-profit) cryonics-associated companies so they can focus full-time on research. When this happens, it is important that the cryonics organization creates a structure to interact with, and benefit from, the work of such individuals and that an open line of communication is retained between these organizations and Alcor.

If funding permits, a growing cryonics organization should employ a full-time quality control officer whose sole responsibility it is to maintain a constant level of care, improve procedures, and write or delegate the production of high quality case reports. Ideally, participation of this officer in cases is limited to ensure impartiality. If the cryonics organization contracts with other organizations for standby or other services it should require that this officer has the right to observe all cases and receive all data.

## **Meta-Analysis**

An important reason for writing case reports is that the data that have been collected and analyzed in case reports (and patient files) can form the basis of a comprehensive meta-analysis to discover patterns, trends, and opportunities for protocol improvements. As of writing, there have been several attempts to look at the quality of care by reviewing selected case reports, data, and video footage but so far, no attempt has been made to look at all Alcor's case data with the aim of understanding the evolution of care, problematic areas, and opportunities for protocol- and policy changes. In principle, it is possible to extend the idea of meta-analysis to cover areas such as protocols, state of readiness, and training. An important reason for doing a comprehensive meta-analysis, followed by periodical updates is that it allows the cryonics organization to develop a series of benchmarks that can be used to manage today's expectations and future directions.



One useful tool for future case reporting and case reporting is to develop a single outcome measure that can be quickly consulted to understand the quality of the case. Some rigorous attempts have been made to create such a measure to estimate the total amount of ischemic exposure in a patient. Such a measure can then be entered as one element in a compound measure that includes other relevant data such as the degree of ice formation and fracturing events. It is important to note here that such a compound measure does not distinguish between events that were within and beyond a cryonics organization's control. For example, a case in which a family member hid the death of a patient for a week would render a very low score, but this poor outcome cannot not be attributed to the cryonics organization. Overall case measures are important, but context is important, too.

### Quality Control Table

The following table lists specific items that need to be addressed / evaluated in any proper cryonics quality assurance / quality control program. This list is not exhaustive and other items could be added to guide quality control management and case reporting.

<b>Readiness</b>	<b>Stabilization</b>	<b>Cryoprotection</b>	<b>Cryopreservation</b>
Personnel	Cooling rate	Weight gain/loss	Ice formation (CT)
Protocols	End-Tidal CO2	Brain dehydration (CT)	Fracturing
Documentation	Blood gases	Pressure	Temp. Maintenance
Training	CPS data	Refractive Index	
Kit Maintenance		Viability (K/Na)	
Local groups		Ultrastructure (EM)	

## Appendix 2: Writing Case Reports

### Introduction

The most important reasons for writing case reports are:

1. *To provide a transparent and detailed description of procedures and techniques for members of the cryonics organization and the general public.* Writing case reports “forces” cryonics organizations repeatedly to document its procedures and protocols in detail. A cryonics organization that never writes anything about its cases and procedures should be treated with more caution than an organization that does.
2. *To validate current protocol and procedures in general, and actual implementation in particular.* A case report should not only record what happened but should be used for guidance as to what should happen in the future. A detailed case report, especially when a variety of physiological data has been collected, contains a wealth of information that can be analyzed for the team members’ and patients’ benefit. Cryonics cases are relatively rare compared with other medical procedures, so we should try to learn as much as we can from the cases we perform. A series of case reports can be used for meta-analysis.
3. *To serve as a medical record to assist with future attempts to revive the patient.* Although advanced future medical technologies may make it possible to determine the physiological condition of the patient down to the molecular level, it is important to provide as much medical information as possible to help in efforts to revive patients. Having a detailed record of the patient’s condition prior to pronouncement, subsequent stabilization, and cryoprotection, may also help the organization in establishing the desired sequence of revival attempts.
4. *To gain more scientific credibility.* If we want scientists and physicians to take us seriously, we need to convince them that we are attempting to cryopreserve our patients in a scientific manner. Professional case reports can provide this kind of credibility.

This article will mainly concern itself with the general question of how a case report can help a cryonics organization in improving protocol, techniques, and skills.

### Protocol

To be able to assess the quality of patient care in a cryonics case, it is important to recognize what the intended protocol was prior to writing about the case. Only if we know what the organization was *supposed* to do will we be able to assess how successful the case was. For example, if there is no mention of collecting (and analyzing) blood gases during a case this may have been because it is currently not a part of the organization’s protocol, but it may also be the result of a shortage of skilled personnel, defective equipment, or other problems and deficiencies. Unless the writer of the report specifies what should have happened, it is difficult to assess the quality of preparation and performance. If preparation for the case was limited and there was no (functional) extracorporeal perfusion equipment available, the case report should not simply state that the organization did a case without substituting the blood with an organ preservation

solution, but also identify and review the logistical factors or errors that were made that prevented a washout in the field. Since Alcor has a written protocol for all its major procedures, a case report can also refer to this instead of completely articulating it in the report. At a minimum, the case report writer(s) should check the performed procedures against the documented protocol (if available) and discuss changes or omissions in the report.

In practice there will be many deviations between the organization's protocol and what happens during a case. Human cryopreservation cases are not controlled laboratory experiments, and as many people who have extensive experience doing cases know, unique situations present themselves, including frustrating events that are beyond the control of even the most skilled medical professional. Nevertheless, the inherent unpredictability and uniqueness of cryonics cases is sometimes used as a reason for failing to follow established protocol, or for errors and omissions in patient care. Recognition of the intended protocol will help us to gain a more systematic understanding of what is possible (or essential) and within our control, versus that which is not.

### **Detail**

The importance of writing detailed descriptions of the procedures and techniques employed during a case cannot be overestimated. This not only enables the reader to gain a comprehensive understanding of the techniques used, it also allows detailed analysis of the difficulties that were encountered during a case that would not have been noticed if there is only a brief mention of it. For example, instead of simply noting that medications were administered, providing comprehensive details and timelines is essential.

Case reports should be prepared with the possibility in mind that what may seem mysterious, or inexplicable, to the writer may be crystal clear to an expert or perceptive reader when provided with sufficient detail. Providing as much detail as possible also serves to allow for replication of the techniques used by others. This is a critical component of the scientific method. Other investigators or practitioners must be able to duplicate the procedures and obtain the same outcome. Yet another consideration is that factors currently not considered to be important may become so in the future. There are many examples of this in the history of cryonics that have proved essential to improving patient care. For example, in the early days of cryonics bags of ice were used to facilitate external cooling. It was not until comprehensive and consistent core cooling data were collected that it became apparent that this technique required 6-8 hours to cool a patient to approximately +20°C (room temperature) with the patient cooling at a rate of 0.064°C/min. Documentation of these very slow cooling rates provided powerful incentive to develop stirred water ice baths which increased cooling rates to between 0.15°C/min and 0.33°C/min, allowing cooling to about 15°C within 90 minutes to 2 hours after the start of cardiopulmonary support (CPS) (see graph below).

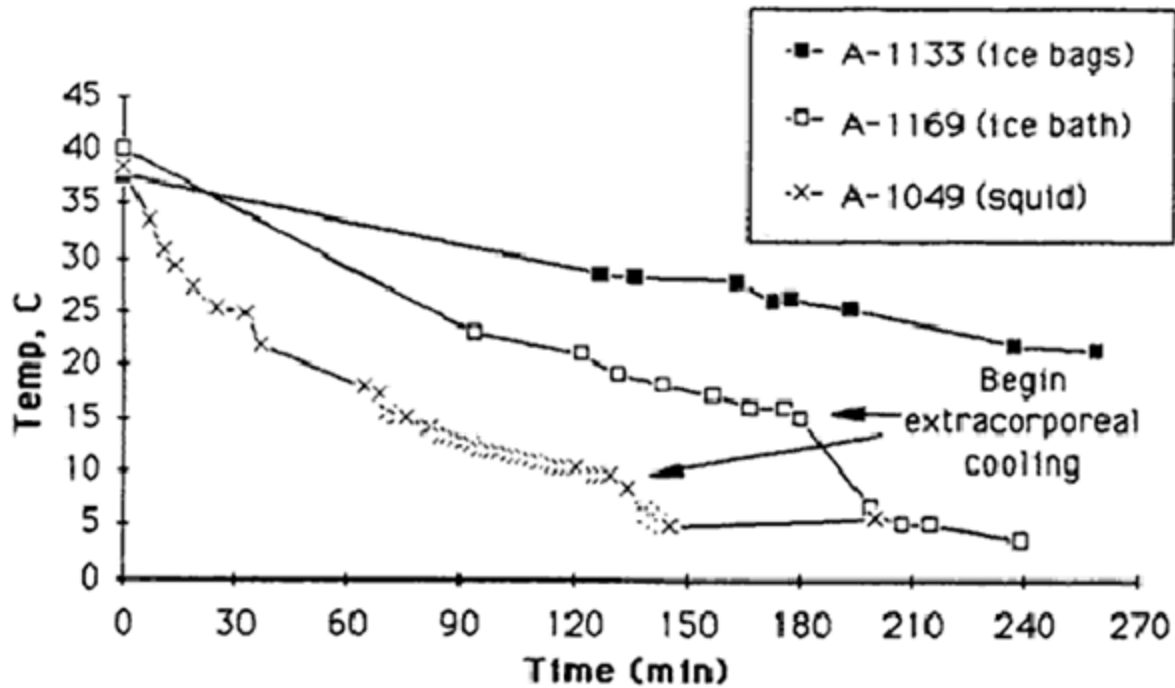

*Comparison of Cooling Methods: Above are actual cooling curves for three adult human cryopreservation patients on Thumper support, using ice bags, the Portable Ice Bath (PIB), and the PIB augmented by SCCD (squid) cooling. Patient A-1133 weighed 56.8 kg, patient A-1169 weighed 57.3 kg, and patient A-1049 weighed 36.4 kg. As this data indicates, PIB cooling is approximately twice as efficient as ice bag cooling. The SCCD appears to increase the rate of cooling by an additional 50% over that of the PIB, (roughly adjusting for the difference in the patients' body masses). Source: [Case Report Arlene Fried \(A-1049\)](#).*

This example is even more instructive because continued diligent and comprehensive monitoring of cooling in multiple patients made clear other factors that were critically important to good outcome or, conversely, prohibited it. A large-framed obese male with heavy fat cover and a large amount of thermal inertia will not cool at anywhere near the rate that an emaciated, petite woman will. Evaluating the patient for fat cover and body mass index before circulatory arrest allows reasonably accurate prediction of the cooling rate and may suggest the need for the addition of other cooling modalities such as “liquid ventilation” or peritoneal lavage with chilled fluid. Favorable results from application of peritoneal cooling in turn will suggest that even greater rates of cooling are possible for all patients and lead to the addition of the modality as a standard part of the protocol.

Failure to gather and promptly analyze data as basic as cooling rate precludes realization that problems exist as well as any possibility of solving them.

It is important to note that an incomplete case report doesn't necessarily indicate failure on the part of a cryonics organization. In a case where the number of team members is limited, all resources may have to be devoted to *doing* the case, instead of collecting data, or assigning an essential person to the job of taking notes. In the case of limited personnel, it is better to do a

good case without documentation than to document a bad case. To some degree this conflict between tasks can be avoided by having some of the team members (the team leader, paramedic, etc.) use a voice recorder with a clip-on microphone. But if the number of team members is insufficient, and data collection is not possible, this should be reported in the case report and recommendations should be made and implemented to prevent this situation from occurring again in the future. After all, deployment of insufficient team members is itself a breach of an organization's deployment protocol. Good data acquisition and scribe work are essential for a good case report and, if feasible, should be a full-time job during a case.

## **Analysis**

Specifying the protocol and describing the case in detail is necessary but not sufficient. A critical review of the information and data culminating in a list of desired changes and specific plans to address them should complement this. Ideally every discrepancy between protocol and reality that has been observed during the case should be discussed. Even in a case where stabilization started promptly after pronouncement, and the protocol was followed to the letter, there is still a lot of (physiological) data that, once analyzed, may require a change in the protocol in future cases.

To assess skills, identify critical failures, formulate solutions, and compare cases in a meaningful and valid way, a consistent and systematic format of reporting cases is essential. A typical case report should be divided into sections describing protocol, patient assessment, preparation and deployment of standby assets, the details of the case (divided in sections such as airway management, cardiopulmonary support, external and other cooling methods, blood washout, cryoprotective perfusion, and cooling to storage temperature), analysis, recommendations, and a variety of (public or non-public) appendices. Such appendices should include time-lines and graphic presentation of data, medications, cryoprotectants, and statistical analysis and comparisons to other cases.

Each case report should not only present solutions, or suggest tests and experiments to identify solutions, but provide a plan of action as to how these things can be accomplished. One approach to ensure that research and tests to validate solutions are implemented, and appropriate remedial action is taken, is to appoint an officer in the organization who is responsible for quality assurance and quality control. This individual's job will be to ensure that case reports are written in a manner consistent with the guidelines as outlined by the organization, as well as to ensure implementation of required changes. It is important to ensure that any issues identified in a case are implemented in the next case (if feasible) and the following case report can then document the implementation of these measures.

Another critical role of case reports is to educate the organization's staff as well as consultants and, where appropriate, the patients' physicians and other health care providers about protocol, procedures and techniques. Although case reports are not and should not be a substitute for comprehensive written protocols, standard operating procedures (SOPs), and thorough training of personnel, sometimes solutions to problems can only be found in case reports where a team member was presented with an unusual problem. Consistent and systematic organization of case

reports will greatly enhance the utility of case reports for this purpose. For example, if a reader wants to know about surgical techniques, and problems encountered in gaining access to the circulatory system for blood washout, consulting a case report will be far easier if they're organized in a consistent and predictable manner.

### **Answering Objections**

One objection to writing up a case report is that it is not a controlled experiment and at best provides only anecdotal evidence. This is not the case for the following reasons.

Not all the mistakes and issues identified are of a hypothesis testing nature. For example, if a patient presents team members with a problem that could not be managed with the equipment at hand, the cryonics organization doesn't necessarily need a larger number of cases to decide to make a change to their equipment and can start teaching employees the use the new equipment right away.

Similarly, what may be perceived as anecdotal evidence for the cryonics organization may be a consistent finding in nearly identical settings in mainstream medicine. For example, some issues during a human cryopreservation case may be well known in hemodynamic management of potential organ donors in hospitals, or, for example, a medication in the protocol that is undergoing trial as a stroke therapy may demonstrate the same adverse effects observed during transport of a cryonics patient.

Of course, such lessons are impossible to learn without broad and deep knowledge of medicine and the relevant research literature. Considering the ever-growing number of publications and hyper-specialization, case reports may increasingly become collaborations between numbers of people with expertise in diverse areas. The individuals with the most valuable input do not necessarily have to be the ones who did the case. A physician dealing with similar issues in a neuro-intensive care unit may identify problems and propose solutions not obvious to those delivering cryonics care to the patient. While the input of team members is necessary for a good report, it does not mean that they will be the most obvious writers of the report.

### **Monitoring**

We don't know for sure how our patient is going to fare in the future but we can know a lot about how our patient fared up to the point of long term care if we monitor his condition continuously. This starts from collecting detailed pre-mortem medical data to monitoring fracturing events during cooldown and doing CT scans.

It is tempting to say that a case went very well if all the steps of the protocol were followed in a timely manner. This is not unreasonable because one would expect a strong correlation between an evidence-based protocol and optimal care. But it is important to keep in mind that the goal of stabilization and cryopreservation is to treat the patient and not the book (as a saying in emergency medicine goes).

Without comprehensive monitoring of the patient through all parts of the procedures a case report will only document a predictable series of mechanical steps and some crude visual

indicators of (relative) success at best. The things we are really interested in, like (quantitative) end-tidal CO<sub>2</sub> measurements, cardiac output, pH, and cerebral oxygenation, cannot be observed without sophisticated equipment.

Not only do we want to know how the patient is doing after the fact, we would also like to be able to intervene *during* a case if we observe a trend that suggests (alternative) treatment. Only in-depth reporting and analysis combined with a sound understanding of the physiopathology and available treatments will enable us to do so.

## **Presentation**

A comprehensive list of dos and don'ts in writing case reports is not something that can be explored in this article, but some things are worth mentioning. Stylistically, a human cryopreservation report should resemble a medical or research report rather than a sensationalized adventure for the patient or the standby team. This should apply to the organization of the material as well as the choosing of words. As a rule, mainstream medical terminology should be used instead of cryonics jargon or abbreviations that are only known and used within a particular facility. Editorializing should be limited, and if perceived necessary, be moved to the proper section of the report. For example, jumping from a technical description of procedures to quarrelling among relatives or complaining about government regulation doesn't look very professional. Adverse actions of individuals or organizations that must be reported because the actions materially impacted the case should be described objectively and dispassionately without speculation about motive.

Protocol, procedures, and techniques should be the subject of the report, not people. Cryonics preparation and procedures are very demanding and exhausting for all people involved and mistakes are made and will be made. Errors should be presented as dispassionately as possible to avoid a culture of blame and personal conflict. Experience also teaches that (potential) participants are more open to transparent reporting if a case report will not single out individuals by name in describing procedures. Issues that involve performance of specific people should be dealt with internally during case debriefings, not formal case reports.

No matter how competent the writer of the report is, each report should be proofread by most or all individuals who were involved in the case and, if possible, a variety of outsiders with appropriate technical and medical knowledge, before it is released to the public.

## **Confidentiality**

If the patient of the case report selected in their membership paperwork to remain private after cryopreservation, then the public version of the case report must be stripped of all information that could be used to identify the patient. Pseudonyms may be used as appropriate, and identified as such. At least two people should independently confirm the public or private status of the patient by examining the most recent set of signup documents on file.

No non-staff members involved in the case, whether contract team members, volunteers, family members, medical personnel, funeral directors, or government officials should be identified by name in a public case report without permission of the individual. Similarly, company names,

such as funeral homes, hospices, or airlines should not be identified in public case reports without permission. Doing so might jeopardize cooperation in the future.

Public case reports should also exclude any medical history or case details that compromise the dignity or privacy of the cryopreserved person, whether the person is identified or not. Examples of such details include history of cosmetic surgery, substance abuse, sexual history, and mental health unless mental health was central to the cause of legal death. Writers and reviewers of case reports should edit the public version of case reports as though the report was describing their own cryopreservation. If there is doubt about whether a case detail is too personal, it should be excluded from the public report.

### **Patient Care**

Writing case reports as presented in this article may be more demanding and time-consuming than generally has been done in human cryopreservation, but the results may improve patient care to a degree not previously seen. Ultimately, the most ambitious use of case reports will be one in which the case reports are analyzed as a series, measurements are compared, and patterns are established. Reading (and evaluating) a series of case reports in a systematic manner will even enable us to answer some very fundamental questions as to whether, or the degree to which, protocol, procedures, and techniques have improved over the years. A meta-analysis can also reveal what the typical expectations (cooling rate, duration of CPA, cryoprotective perfusion time, edema etc.) for a cryonics case should be given a certain protocol.

Providing the best patient care possible for current and future patients is the reason why cryonics organizations exist, and considering how powerful a tool a good case report can be, a responsible cryonics organization should devote considerable resources and time to writing them.

As our members and resources increase, and human cryopreservation gradually becomes a part of mainstream medicine, the successful transition from basic algorithmic, volunteer-driven care to evidence-based cryonics will be an important mandate.

### **Case reports and increasing caseload**

One of the biggest challenges facing a growing cryonics organization is that it will also have more cases per year. This challenge is further amplified if all these cases need to be documented. Consequently, a cryonics organization will find itself allocating an increasing amount of time to writing case reports and falling behind publication schedule. One of the most unfortunate responses to such a development would be to try to keep writing case reports in the expected style but to lower standards and take short cuts.

An alternative approach is to develop a new format for case reports that allows for a shorter report but still captures the essential objectives of case reporting. One approach is to eliminate all the narrative that is not essential for following the mechanics of the case and evaluating the quality of care. In the past there have been several case reports with excessive narrative but little technical reporting or analysis. For a cryonics organization with a growing caseload the opposite approach should be followed. Another approach is to eliminate detail about procedures that were performed without deviations from past protocol and expectations, provided that this is made



explicit in the report. As a result, case reports will increasingly read as a description and commentary on events that diverged from protocol or new observations about existing procedures.

To establish a template for such case reports the following approach can be followed. First, it is established what kind of information is essential for doing a meta-analysis of all cryonics cases. Then these parameters are reverse-engineered to create a template for writing case reports that reconcile the need for economy of expression and documenting all the relevant aspects of a case. One important advantage of producing such case reports is they permit easier consultation of the technical details of the case and still meet the fundamental objectives of writing case reports.

Another attractive approach for writing case reports in an era of many cases is to identify one or more important issues or achievements in a case and build the report around this. This approach is consistent with the medical literature where case reports are often produced for patients with unusual outcomes, extraordinary interventions, or new medical developments. For example, a case could be published as “A-20xx: Extraordinary Cooling Rates Achieved During Stabilization” or “A-12xx: Patient with Fracture-Free Storage at Intermediate Temperatures”. It should not be hard to find one or two important themes in the case data to justify such an approach. Writing case reports in this manner can be more rewarding for the writer and more engaging to read for the average reader.

The history of case report writing in cryonics shows an erratic potpourri of approaches and styles. One of the most unfortunate casualties has been the objective of using case reports to improve the practice of human cryopreservation and to formulate meaningful research questions for the sciences that inform cryonics. But if systematic thought is given to the objectives of case reporting outlined in this document, steps can be taken to leave this unsatisfactory situation behind while meeting the needs of a growing cryonics organization.

### **Who should write the case reports?**

Historically, the tradition at Alcor was that a team member with the best writing skills and technical acumen wrote the case reports. As Alcor’s caseload increased, this responsibility increasingly has shifted to the team leader and/or paramedic that was employed at Alcor. On the surface this does not appear to be an unreasonable choice but there can be complications. First, EMS personnel are not necessarily skilled writers or have the technical acumen to write scientific evaluations of a case. Another problem is that there is a potential quality control conflict of interest issue when the person responsible for leading the case is also the writer. A possible solution is to recruit a quality control officer who is also responsible for writing the case report. This approach permits a more dispassionate analysis of the case and prevents skilled medical professionals being taken away from further education, training, and readiness responsibilities. A disadvantage of case reports prepared by persons not present is lack of direct knowledge of what transpired during the case. If different individuals write reports (which can happen when an organization tries to clear a long log of reports) it is still important to use a consistent template and style. Meta-analysis of large numbers of case reports becomes a lot more complicated when each case report is structured in a different manner.

A common flaw in case reports is high variability in procedure detail and data in a single report. Often this issue can be attributed to the practice of merging materials from various individuals and organizations without checking for (stylistic) consistency. A typical example of such a report is one with detailed stabilization report from the standby contract organization, an almost non-existent cryopreservation narrative from Alcor, followed by extensive unedited timelines.

### **Common flaws in case reports**

The following list of recurring issues needs to be avoided in professional cryonics case reporting. In case of doubt, use mainstream medical case reports as a benchmark.

Inconsistent organization of the text from report to report

Improper use of team member names or cooperating people and institutions

Irrelevant anecdotal or biographical information

No reference to the protocol that should have been followed

Unedited, or excessively detailed, timelines

Detailed information about one procedure and little information about another

Imprecise nomenclature (such as the use of “suspension” or naming a section “perfusion” without specifying the type of perfusion)

No discussion of issues, recommendations, or follow-up actions

### **Notable Case Reports**

1984

#### **[A-1056, A-1057 and unidentified patient](#)**

For all three patients fluid samples were obtained from the body of the patients after neuro conversion. The report specifies cryoprotectant osmolalities for all three patients in fluids obtained from different parts of the body. The author suggests that the low and variable distribution of cryoprotectant can be attributed to low volumes of the cryoprotectant and ischemia-induced perfusion impairment.

1985

**[A-1068](#)** This case report contains an extensive discussion of blood, washout perfusate, and cryoprotectant perfusate samples.

1987

**[A-1133](#)** This case report has an extensive appendix with graphs of blood gases, electrolytes, and enzymes data during cryoprotective perfusion.

1990

[A-1049](#) One of the most comprehensive studies of a cryopreservation case ever written. This case also stands out for conducting a renal viability evaluation, which was possible because the patient was a neuro patient. The patient's kidney was subjected to renal slice intracellular/extracellular potassium/sodium ratio tests in a cryobiology lab and the average ratio of 3.5 corresponds to the expected value for such slices after a hypothermic storage time of approximately 2.5 days.

1995

[A-1871](#) Detailed technical case report of the first cryopreservation by *CryoCare*, which was transferred to Alcor in 2001. Multiple external and internal cooling modalities are employed in this case.

2002

[A-1876](#) Three boluses of perfluorocarbon, totaling more than 2 liters, were infused into the lungs of this Alcor patient to accelerate cooling, the first and only time basic "liquid ventilation" technologies have been used in cryonics.

2004

[ACS 2004-1](#) Whole body field glycerol cryoprotection case by *Suspended Animation*.

2006

[A-1097](#) The most extensive Alcor case report since the introduction of vitrification. This reports also includes the document "Advances in Cryonics Protocols, 1990-2006". Lowest first fracturing temperature recorded in an Alcor case (-134C)

2010

[A-1712](#) Extensive documentation and discussion of Alcor's response to an autopsy case.