

Chapter 6A

The Michigan Instruments Heart-Lung Resuscitator (HLR)

Heart-Lung Resuscitators (cardiopulmonary resuscitators) provide for both artificial ventilation via a mechanical respirator, and sternal compression via a pneumatically powered piston. Four models are currently in use by Alcor: the Brunswick *HLR 50-90*, and the three variants of the Michigan Instruments MII-HLR. This Chapter will cover operating instructions in detail for the Michigan Instruments High Impulse CPR and the Simultaneous Compression-Ventilation CPR units.

Heart-lung resuscitators are utilized in the transport of cryonic suspension patients because manual cardiac compression and bag-valve ventilation lead to rapid exhaustion of personnel. The effectiveness of manual CPR, which is unsatisfactory to begin with, rapidly deteriorates as operator fatigue sets in. The very long periods (4 to 8 hrs.; perhaps less than 4 hrs. if the Patient Ice Bath (PIB) is used) of HLR support necessary to reduce patient core temperature to a safe level (10°C) mandates the use of a mechanical device.

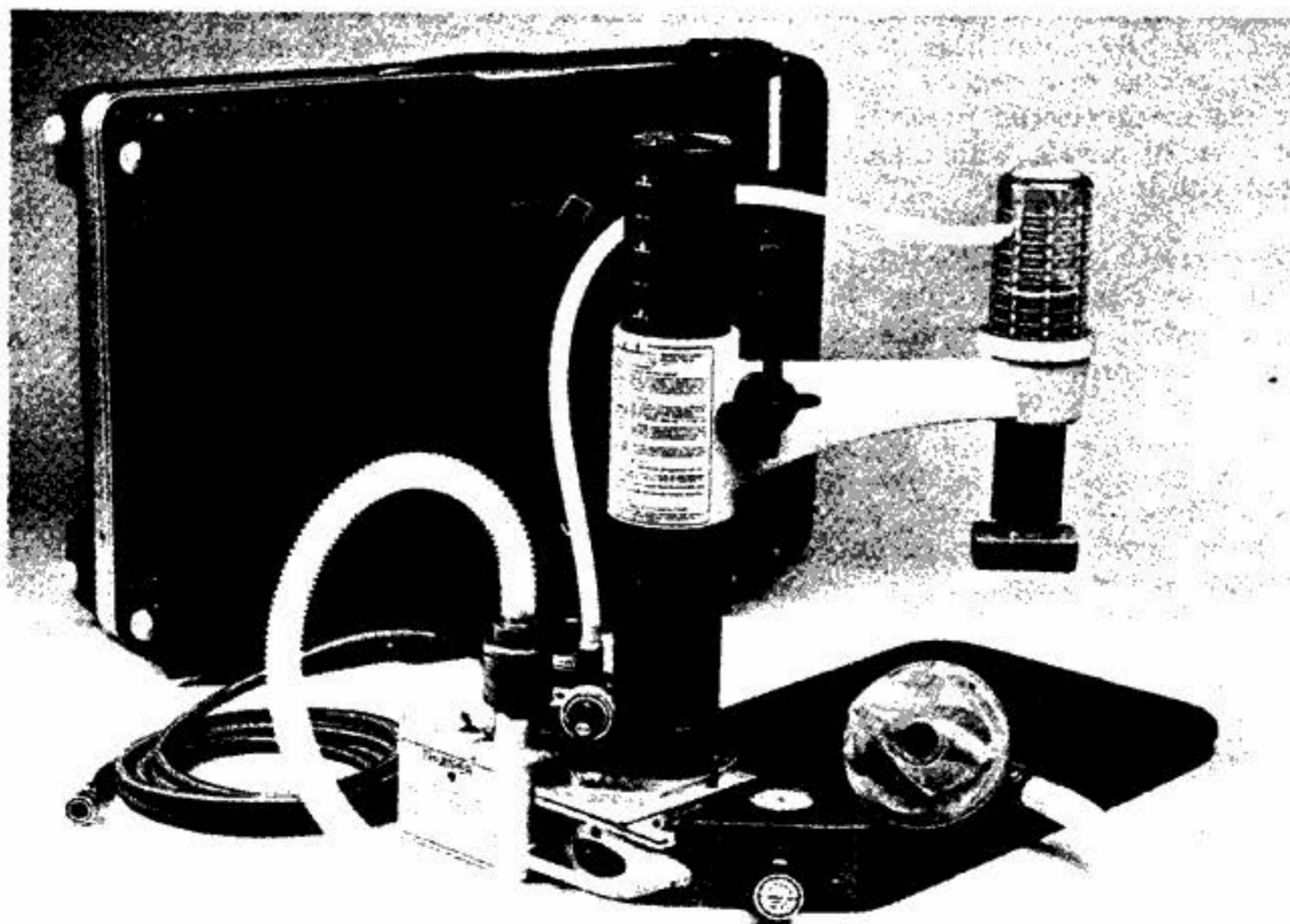

Figure 6A-1: *The MII Heart-Lung Resuscitator.*

As soon as legal death is pronounced, start manual cardiopulmonary resuscitation, using the bag-valve device to ventilate the patient. If the Portable Ice Bath (PIB) is not available, start manual CPR using the Thumper Board or just the Base Plate of the MII-HLR unit. As quickly as possible, insert the EGTA--or endotracheal--tube. Once a stable, patent airway has been secured, initiate mechanical CPR with the HLR. Once the HLR has been installed and is administering chest compressions, connect the mask, endotracheal tube, or esophageal airway mask to the ventilator on the HLR and discontinue valve ventilation.

If the PIB is available and at the bedside, set up the HLR on it, but don't initiate mechanical CPR until the patient is transferred into the PIB, so that no delays in beginning external cooling occur. (Manual CPR *must* be carried out until mechanical CPR can begin.)

It is important to understand that manual CPR is very inefficient compared to machine CPR as delivered by the MII-HLRs currently in use by Alcor. Therefore, every effort should be made to begin mechanical CPR and external cooling as rapidly as possible. Manual CPR should be used only as the briefest possible bridge, just long enough to get the airway secured and to organize the transfer of the patient to the HLR and the PIB.

The Michigan Instruments HLRs

The MII-HLRs are portable, non-electrical, oxygen-powered cardiopulmonary resuscitators. Using pneumatic and mechanical means, they deliver external cardiac compression and artificial ventilation in a coordinated and synchronized manner.

Three kinds of MII-HLR units are in use by Alcor at this time: high impulse CPR (HI-CPR), simultaneous compression-ventilation CPR (SCV-CPR), and an older machine from which these are derived. The new machines are both very similar in appearance, operation, and application to the patient. However, the principles upon which they operate differ radically.

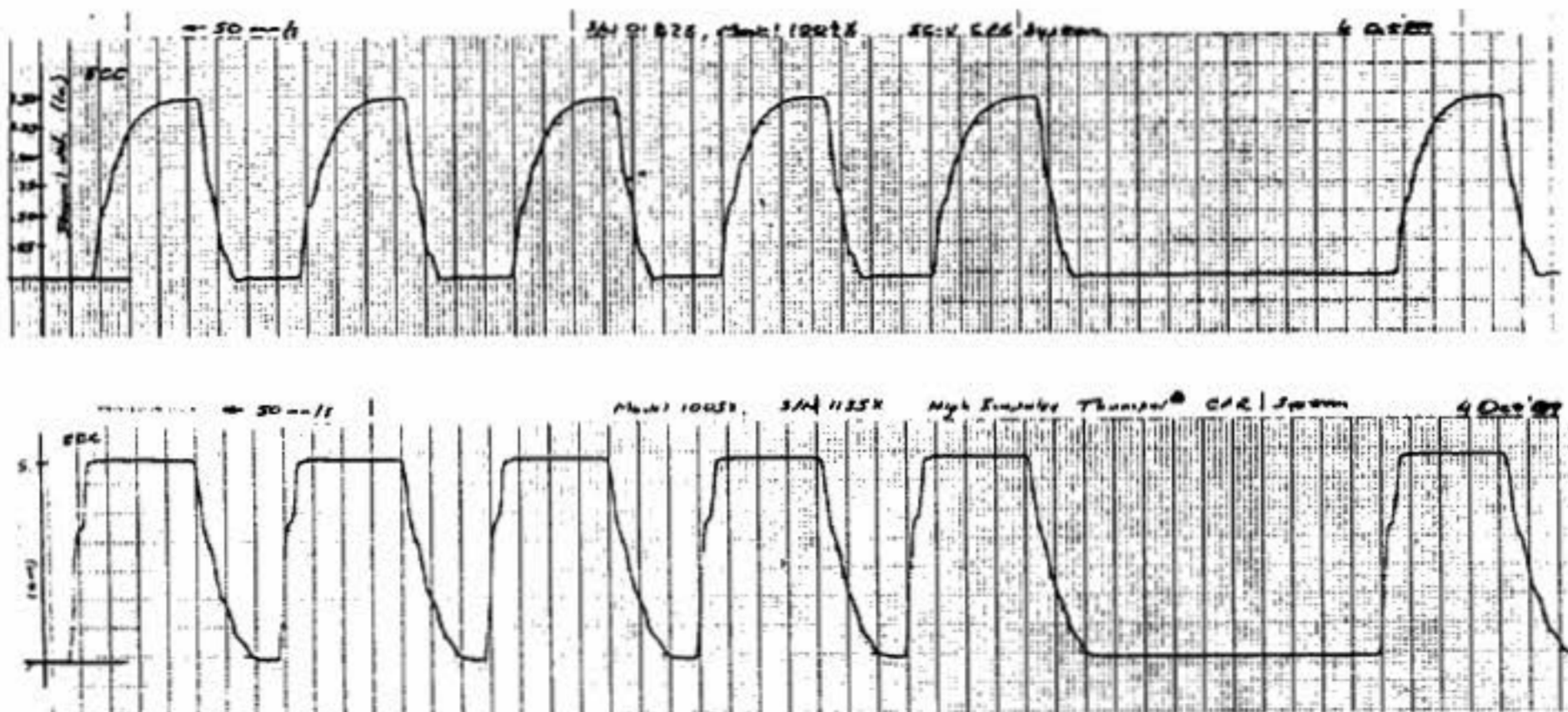

Figure 6A-2: Saw-toothed waveform typical of conventional manual and mechanical CPR (Top) vs. square waveform delivered by High Impulse CPR.

HI-CPR - The HI-CPR unit (MII "Thumper" Cardiopulmonary Resuscitator, Model 1005X) is designed to shape the wave form of the impulse delivered to the patient's chest during cardiac compression. The normal wave delivered by manual or mechanical CPR is saw-toothed, and results in prolonged high intrathoracic pressures. The HI-CPR unit delivers a square wave with resulting very high acceleration of the chest wall. The heart is thus "selectively compressed" by the shock wave. HI-CPR has resulted in cardiac output two to three times greater than that achievable with conventional closed chest CPR and without the prolonged high intrathoracic pressure associated with conventional CPR.

SCV-CPR - The SCV-CPR unit (MII "Life Aid" Resuscitator, Model 1004X) works on a completely different principle than HI-CPR. SCV-CPR uses the entire chest and the blood vessels within it as a "thoracic pump". This is achieved by raising the pressure inside the chest to very high levels during cardiac compression by *simultaneously* compressing the chest and ventilating the patient at very high airway pressures (55 to 95 mm H₂O rather than the normal 25 to 30 mm H₂O used in ventilation).

The unit thus delivers 80 strokes/respirations per minute and interposes a pause in ventilation for *exhalation* after each 5th compression.

CAUTION: SCV-CPR is contraindicated in pulmonary disease where high airway pressures could result in tension pneumothorax (such as emphysema, adult respiratory distress syndrome (ARDS), patients with pre-existing pneumothorax from lung-related causes, and patients with long histories of tobacco abuse in whom lung friability is suspected). Primary or secondary carcinoma of the lung is a relative contraindication: the patient's condition must be evaluated by ASC staff before proceeding to use SCV-CPR.

The MII-HLR HLRs operate on compressed oxygen. In other words, they derive the energy required to compress the chest and ventilate the lungs from a high pressure oxygen supply. While these systems free the operator from dependence on electric power, they have the drawback of requiring large quantities of oxygen. The two standard "E" cylinders (20 cubic feet, or 570 liters each of O₂) which come with the HLR in the Alcor rescue kit will provide approximately 20-30 minutes of operation under normal circumstances (no more than 20 minutes when using the SCV-CPR machine). For this reason, the E-cylinders should be used only where other sources of compressed oxygen are not available for transport of the patient. It is preferable to use a hospital-provided oxygen supply, either in the form of an H-cylinder (220 cubic feet, or 7100 liters) or the wall oxygen outlet, and arrangements should be made in advance, wherever possible.

Switchover from E-cylinders to an H-cylinder or hospital wall oxygen supply may be done without interruption of CPR, since the MII-HLRs have a buffer tank and a special **Oxygen Input Hose** which holds a supply of oxygen sufficient for 4-7 cycles of the HLR. This allows the device to continue to operate during the brief interval required for switchover. The **Oxygen Input Hose** is equipped with a combination check valve/quick disconnect on the end to be connected to the oxygen supply. This valve prevents 50-90 psi gas from escaping from the **Oxygen Input Hose** and buffer tank when the **Oxygen Input Hose** is disconnected from one source of oxygen and switched over to another.

Regardless of whether hospital wall oxygen or an H-cylinder is to be used, the

Respiratory Therapy Department of the hospital must be contacted. Arrangements with them must be made for the presence of an H-cylinder or the availability of an adapter or coupler which will allow the HLR to tap into the wall oxygen outlet. In the event a wall outlet is used, a regulator will be unnecessary, since standard hospital delivery pressure for medical devices is 50 to 90 psi, the operating pressure required by the HLR.

Wall adapters are manufactured in a variety of styles, using a wide range of operating principles. It will be necessary to obtain an adapter for the system which is in use in the particular hospital the patient is in, and to make certain that the adapter does not have any flow restrictions or other devices attached to it (such as an oxygen flowmeter).

CAUTION: It is very important that the check valve/quick disconnect not be removed from the Oxygen Input Hose when connecting the MII-HLR to wall or other oxygen sources. Removal of the quick disconnect from the hose will allow compressed gas to escape from the line and buffer tank, resulting in an interruption of CPR during switchover.

Circumstances Of Use Of The MII-HLR

There may be some situations where the PIB is not available or cannot be used. Examples of such situations are: a) sudden emergency in which the Transport Technician must travel by air with the rescue kit and the PIB (which, due to size, must be sent via *airfreight* rather than taken as luggage) does not arrive before the emergency begins; b) situations in which the Coordinator or Transport Technician is responding alone, or is otherwise unable to physically transport the PIB to the patient (as in cases of sudden local emergencies); c) situations in which the hospital will not allow it to be used, or where manpower sufficient to allow its use is not available.

In such situations, it will be necessary to apply the MII-HLR to the patient and to use ice bags for external cooling. Protocols for use of the MII-HLR both with the PIB and without it are presented below:

Application Of The HLR Without The PIB

Where possible, the HLR should be applied to the patient with only two interruptions in manual resuscitation of not more than five seconds each. This requires the presence of three people on the rescue team, or the availability of bystanders (hospital personnel) to provide some help. After the unit is in operation, only one person is required to monitor its performance and insure an adequate airway. *The HLR should never be allowed to operate without the patient being carefully monitored and attended by at least one knowledgeable individual.*

NOTE: Numbers in parentheses (#) refer to numbers which appear on the controls of the MII-HLR. (They are the same for both models.) Names of HLR controls in bold face refer to the diagrams of the MII-HLR unit, which appear at the beginnings of the sections on the individual units.

Figure 6A-3

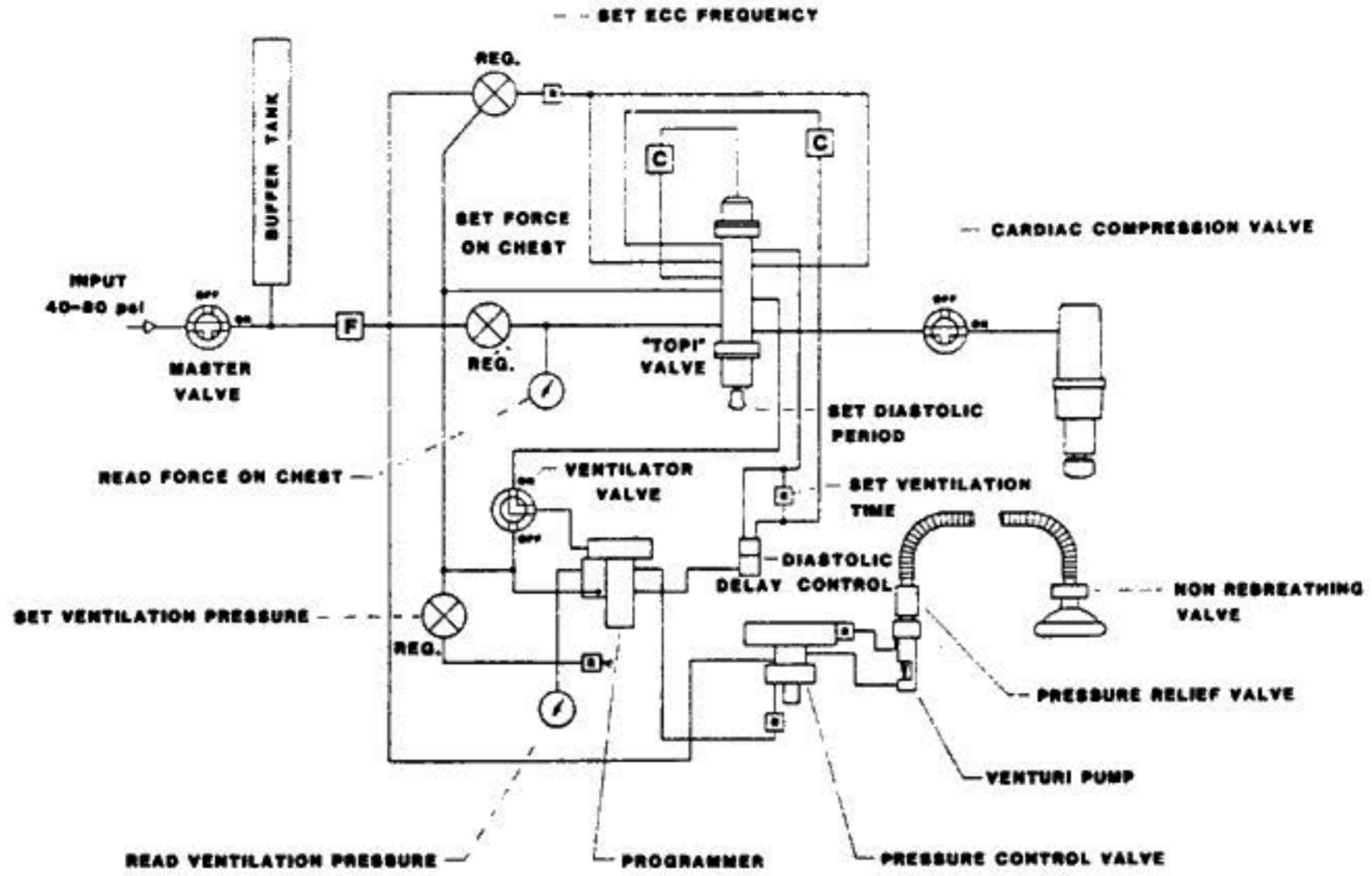

**Functional Schematic Of The MII
High Impulse Heart-Lung Resuscitator**

Figure 6A-4

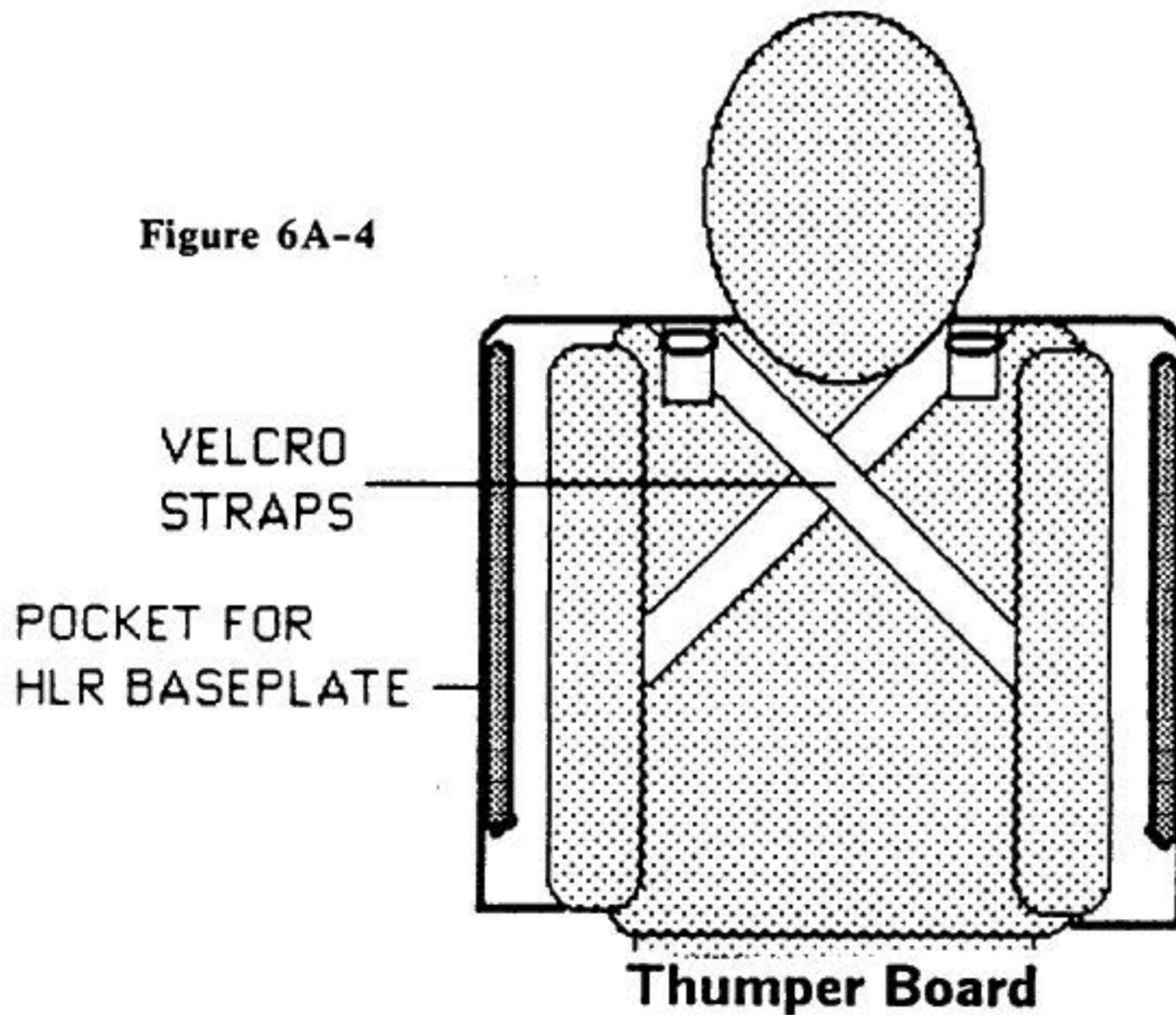

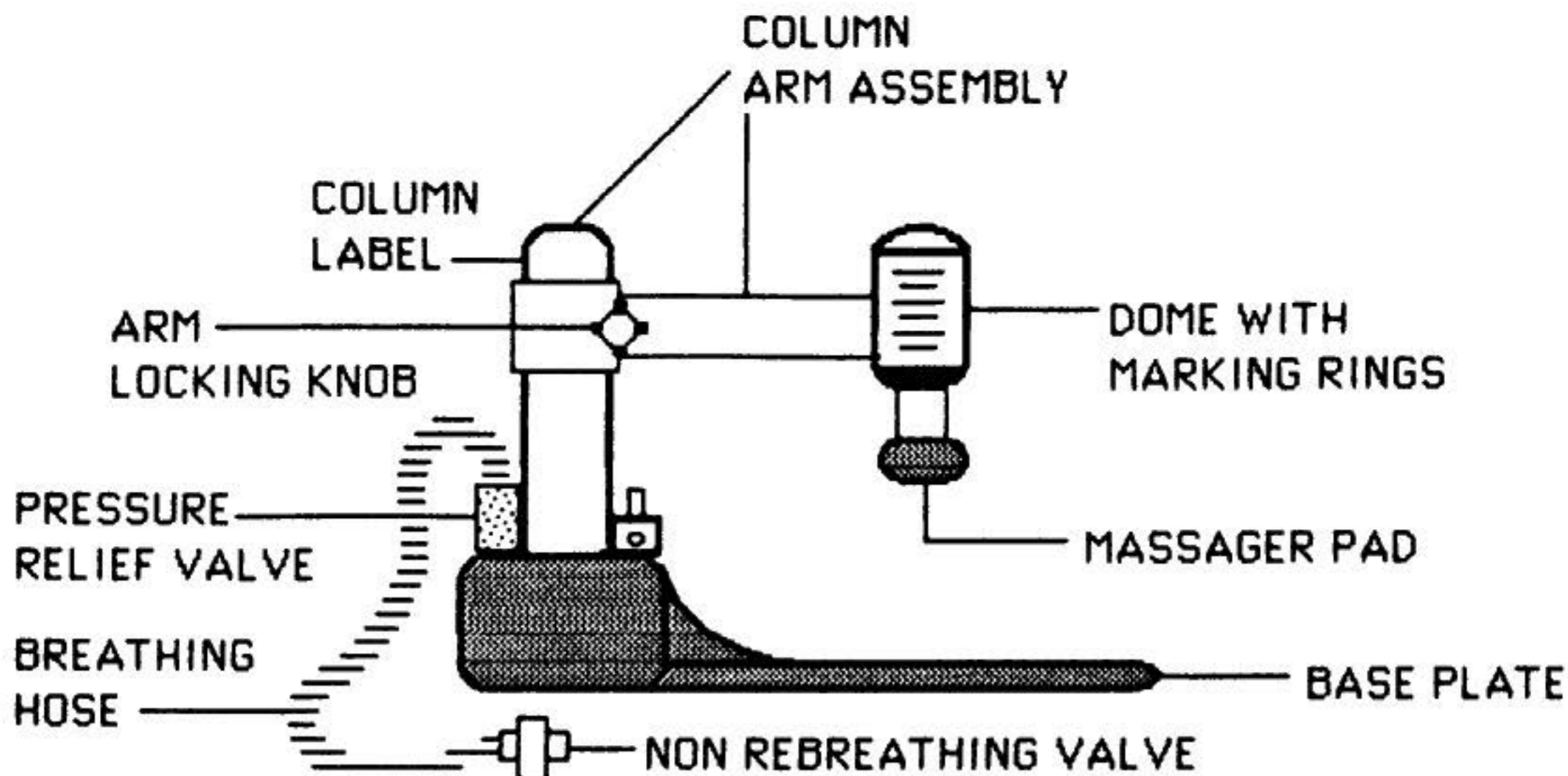

MII High Impulse Heart-Lung Resuscitator
Side View

Figure 6A-5

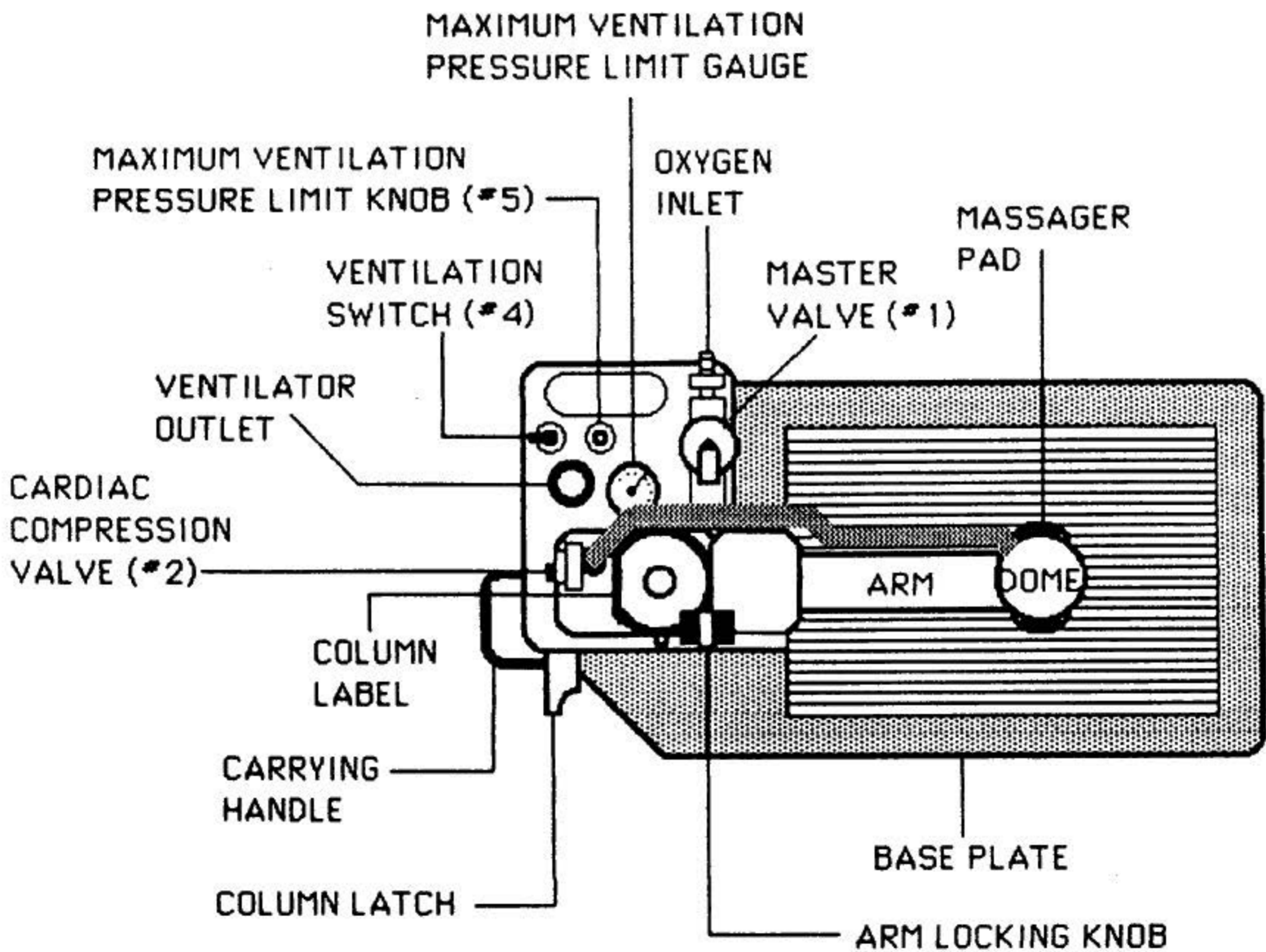

MII High Impulse Heart-Lung Resuscitator
Top View

Figure 6A-6

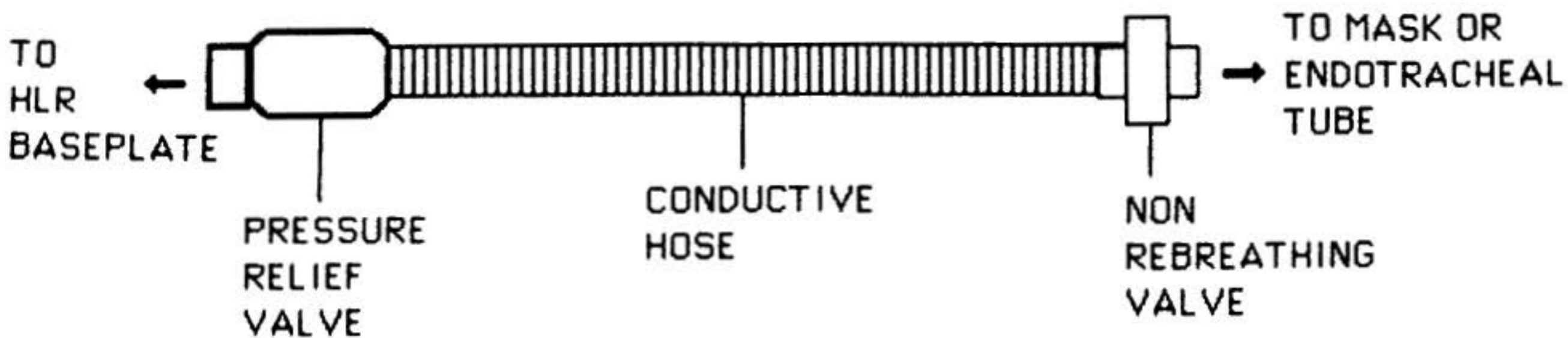

MII Breathing Hose Assembly

Figure 6A-7

High Impulse CPR Unit (MII "Thumper" Cardiopulmonary Resuscitator)

1) During an interruption in CPR of no longer than five seconds, elevate the patient's head and shoulders (or roll the patient onto his side) and slip the **Thumper Board** of the device under the patient with the patient's head extending over the hump at the top of the **Thumper Board** (if the **Thumper Board** has not already been positioned under the patient prior to the start of manual CPR). This extends the head and facilitates opening of the airway and positioning of the patient for intubation, if it has not been carried out already. Manual cardiac compression and ventilation are then resumed. If the **Thumper Board** is not available, place the base plate of the machine under the patient at the start of manual CPR.

2) Insert the **MII-HLR Base Plate** into the **Thumper Board**. To accomplish this, insert the tip of the **Base Plate** into the flared opening between the two plastic sheets and push it into place until a positive stop is felt (the patient need not be moved or lifted to accomplish this). (Figure 6A-8.)



Figure 6A-8



Figure 6A-9

3) Remove the Arm/Column Assembly from the storage case. Holding the column as shown in *Figure 6A-9* (with the Cardiac Compression Valve (#2) toward the rescuer), loosen the Arm Locking Knob and swing the arm 90° on the column towards the patient's feet, then tighten the Arm Locking Knob slightly.



Figure 6A-10

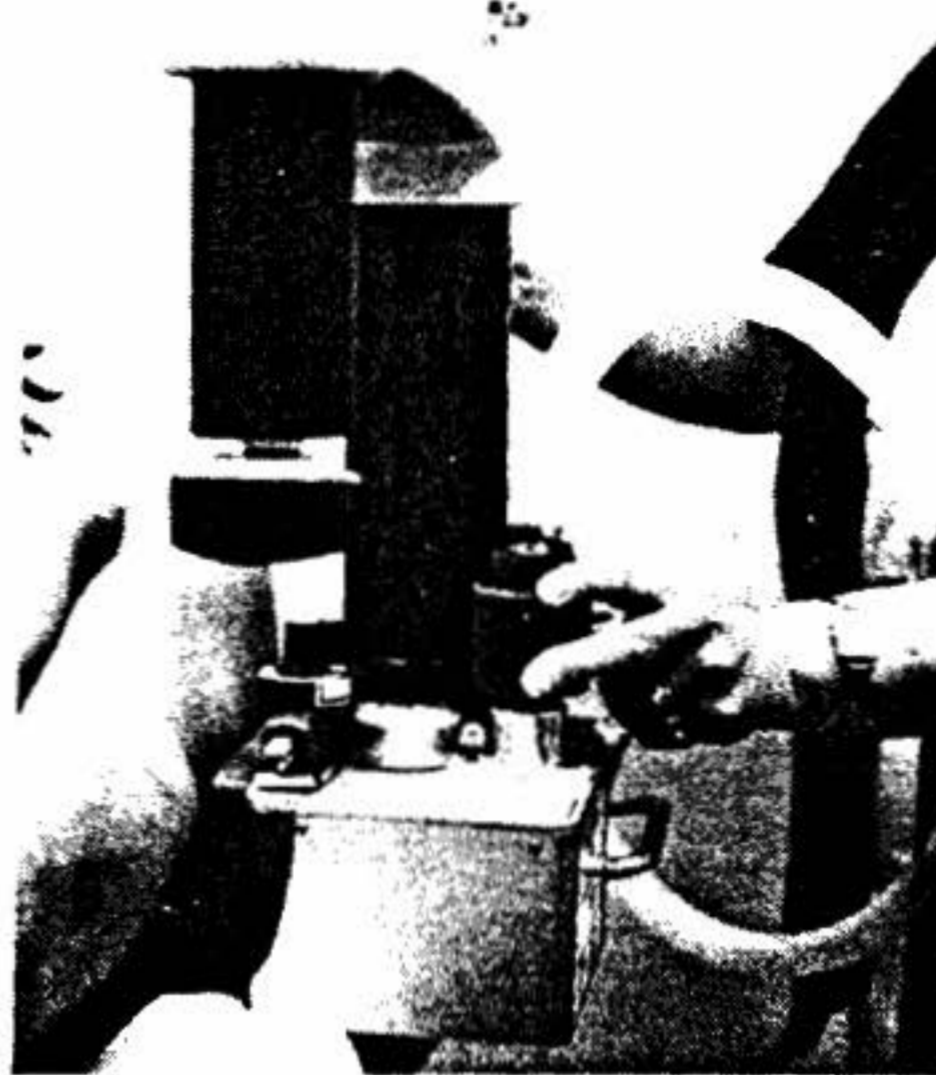

Figure 6A-11

4) Attach the Arm/Column Assembly to the base plate of the HLR, as shown in *Figure 6A-10*. Accomplish this by tipping the column slightly forward, slipping the "toe" of the column base into its slot, then pulling the column back sharply until it is latched.

5) Connect the Pressure Relief Valve (large green fitting) on the end of the Breathing Hose to the Ventilator Outlet per *Figure 6A-11*. Be sure that the end-tidal CO₂ detector has been installed on the patient end of the breathing hose if it has not been previously installed between the EGTA (or endotracheal tube) and the bag-valve resuscitator.



Figure 6A-12



Figure 6A-13

6) Verify that the Master Valve (#1) is in its "OFF" position, then connect the inlet end of the Oxygen Input Hose to a 50 to 90 psi oxygen source (If there is a valve on the source, open it) and the black end (outlet) of the Oxygen Input Hose to the inlet adjacent to the Master Valve (#1) (Figure 6A-12).

NOTE: Connection to the oxygen source must be done first. The hose is normally with the E-cylinder Portable Oxygen Pack; if it is being used, the hose should be left connected.

7) Verify that the Cardiac Compression Valve (#2) is in the "OFF" position (Figure 6A-13), and that the Ventilation Switch (#4) is in the "OFF" position (Figure 6A-14). Turn on the Master Valve.

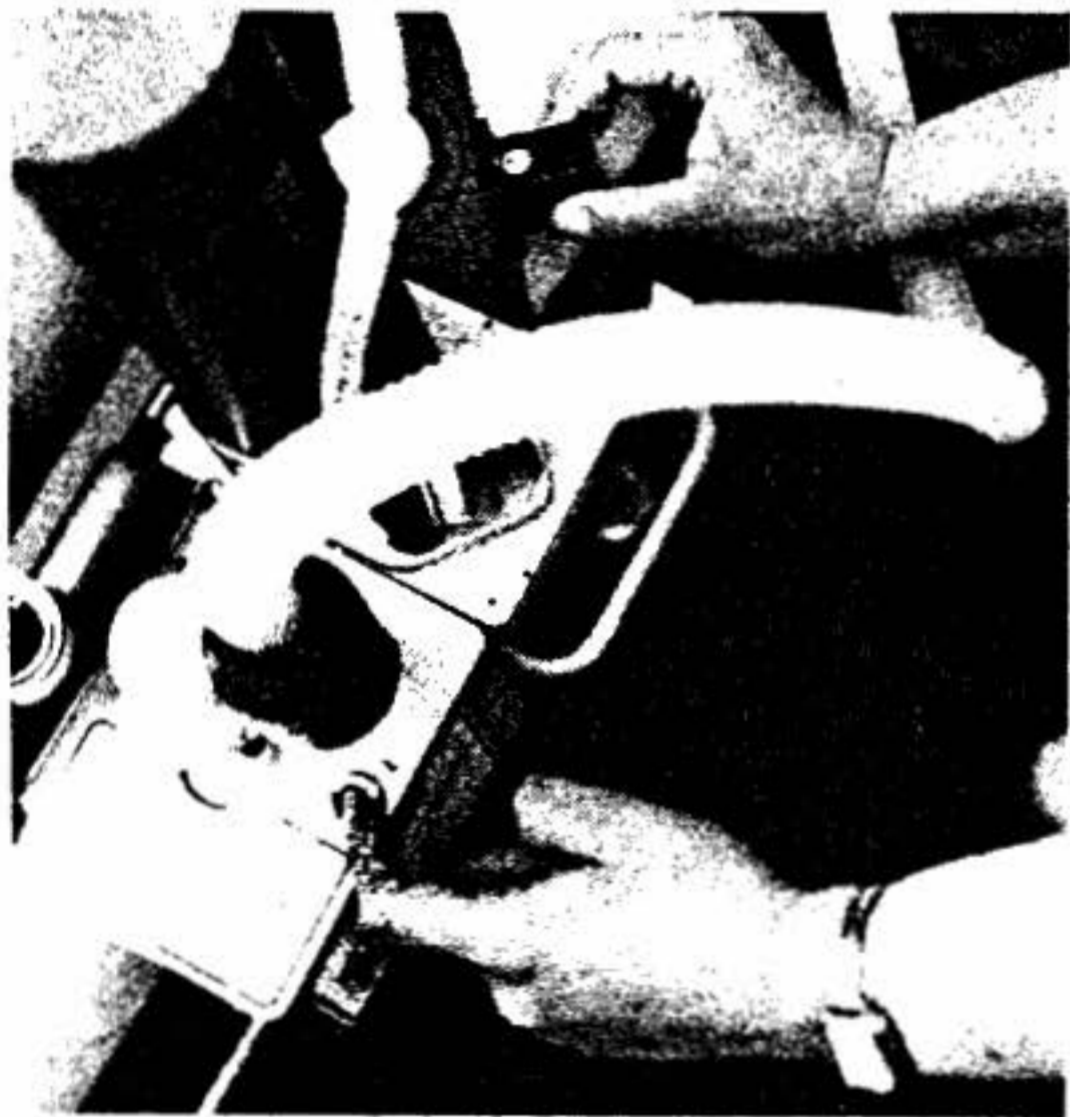

Figure 6A-14



Figure 6A-15

8) Grasp the Piston just above the Massager Pad and raise the Piston up into its cylinder until the white stripe at the top of the Chest Compressor Piston is even with the 9 cm marking on the clear plastic Dome. With the left hand, support the Arm and hold the Massager Pad in place. With right hand, loosen the Arm Locking Clamp.

CAUTION: Wipe the patient's chest dry of any perspiration, electrode paste, antiseptics, melted ice/water, or any other material which might be present and which might contaminate the shaft of the *Chest Compressor Piston*. It is critical that the piston not become wetted or contaminated with foreign material, as it may seize-up and cause the HLR to stop operating. Particular care must be taken when transporting the patient, to avoid wetting the piston with water from the PIB.

9) During the next manual ventilation cycle, quickly swing the Arm over the patient's chest, while lowering it at the same time (Figure 6A-15). Take care to keep the white stripe even with the 9 cm marking. Position the Massager Pad on the lower half of the patient's sternum, and with the massager's long axis parallel to the sternum. The massager pad must not extend beyond the bottom of the patient's sternum (Figure 6A-16). (Not over the patient's xiphoid process.)

10) Read the first number which appears on the Column Label above the arm on the operator's side of the column. This number indicates the recommended initial sternal



Figure 6A-16



Figure 6A-17

deflection setting, and corresponds to 20% of the patient's anterior-posterior (AP) diameter.

Caution! The top is numbered from 6 on top to 3 on the bottom. The line below 5 is $4 \frac{1}{2}$, not $5 \frac{1}{2}$.

11) Raise the Arm back up the column until the white stripe at the top of the Chest Compressor Piston is at the numbered marking corresponding with the number read from the Column Label in Step 10. (If the arm is between two numbers, adjust the Compressor Piston accordingly.) Lock the Arm into place.

12) Turn on the Cardiac Compression Valve. This will initiate chest compressions.

Steps 8 through 12 should be repeatedly practiced so that the time required to set chest compressor deflection does not result in more than a five second interruption in CPR.

13) At the same time as steps 9-12, the Technician in charge of respirations should attach the End-Tidal CO_2 Detector above the endotracheal tube or EGTA.

14) Verify that the maximum ventilation setting is at the normal pre-setting of 25-30 cm of H_2O . This maximum pressure limit setting is read continuously on the Maximum Ventilation Pressure Limit Gauge once the Master Valve is turned on. If incorrect, it can be adjusted by rotating the Maximum Ventilation Pressure Limit Control Knob (#5) (clockwise to increase, counterclockwise to reduce). When the ventilator pressure has been so set, attach the end of the Breathing Hose to the End-Tidal CO_2 Detector, and turn the Ventilation Switch (#4) to the "ON" position (*Figure 6A-18*).

15) The carotid arterial pulse should be evaluated and verified as present with each chest compression. A chest rise of 0.6 to 1.9 cm, dependent upon patient size and measured by piston motion within the Dome, should be visible with each ventilation cycle. End tidal CO_2 concentration should be no less than 3%. (If it is below 3%, something is seriously wrong. See Chapter 5, *Cardiopulmonary Support: Evaluation And Intervention*, especially page 5-5, for possible corrective actions.)

16) The Transport Technician should continue to monitor the unit for proper equipment function and proper settings, and monitor the patient for palpable pulse, adequate chest rise during ventilation, and adequate end-tidal CO₂. If the pulse is weak or undetectable, sternal deflection can be increased by lowering the column height. If chest rise is inadequate, the maximum ventilation pressure limit should be increased by turning the Maximum Ventilation Pressure Limit Control Knob (#5) clockwise to increase the limit pressure.

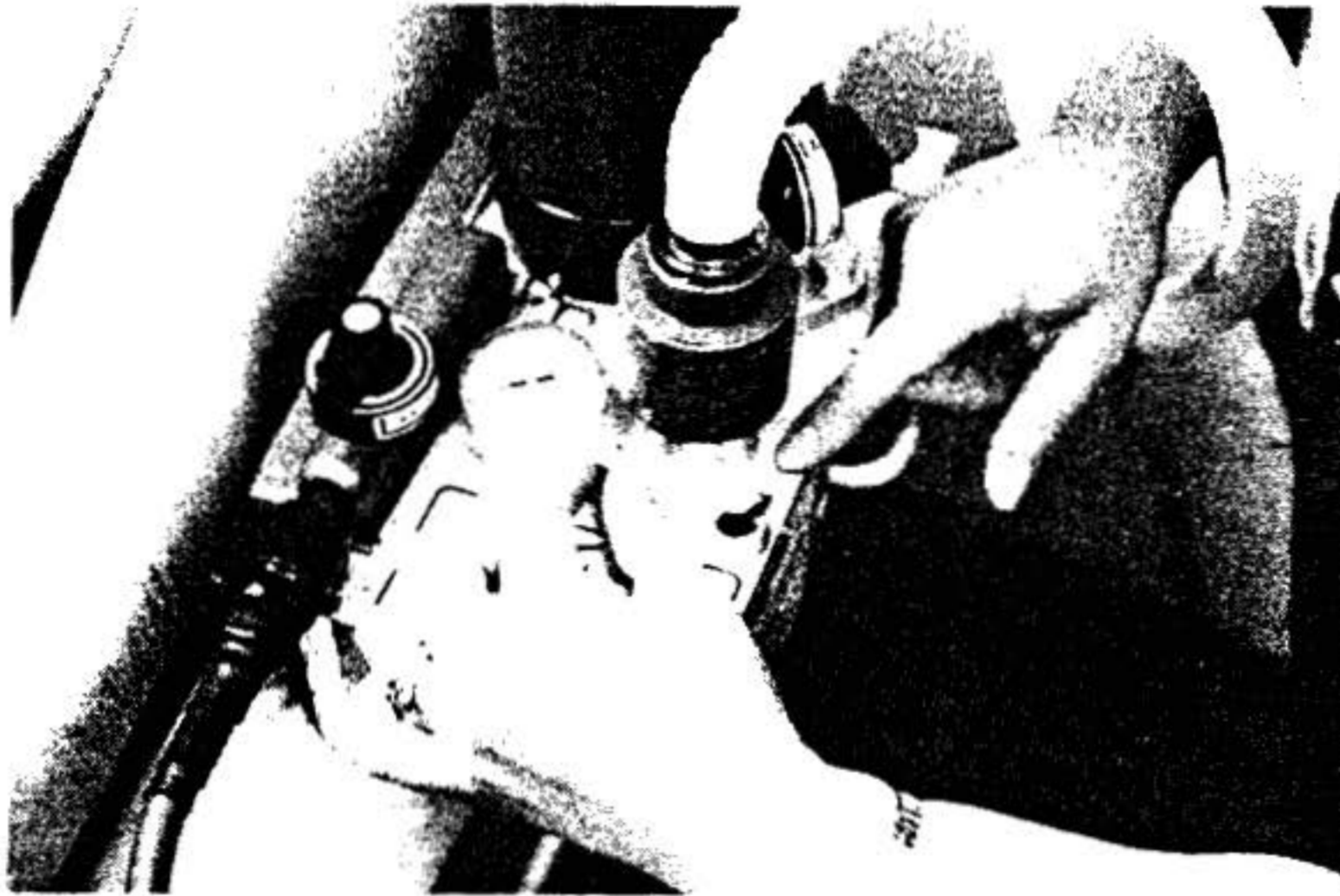
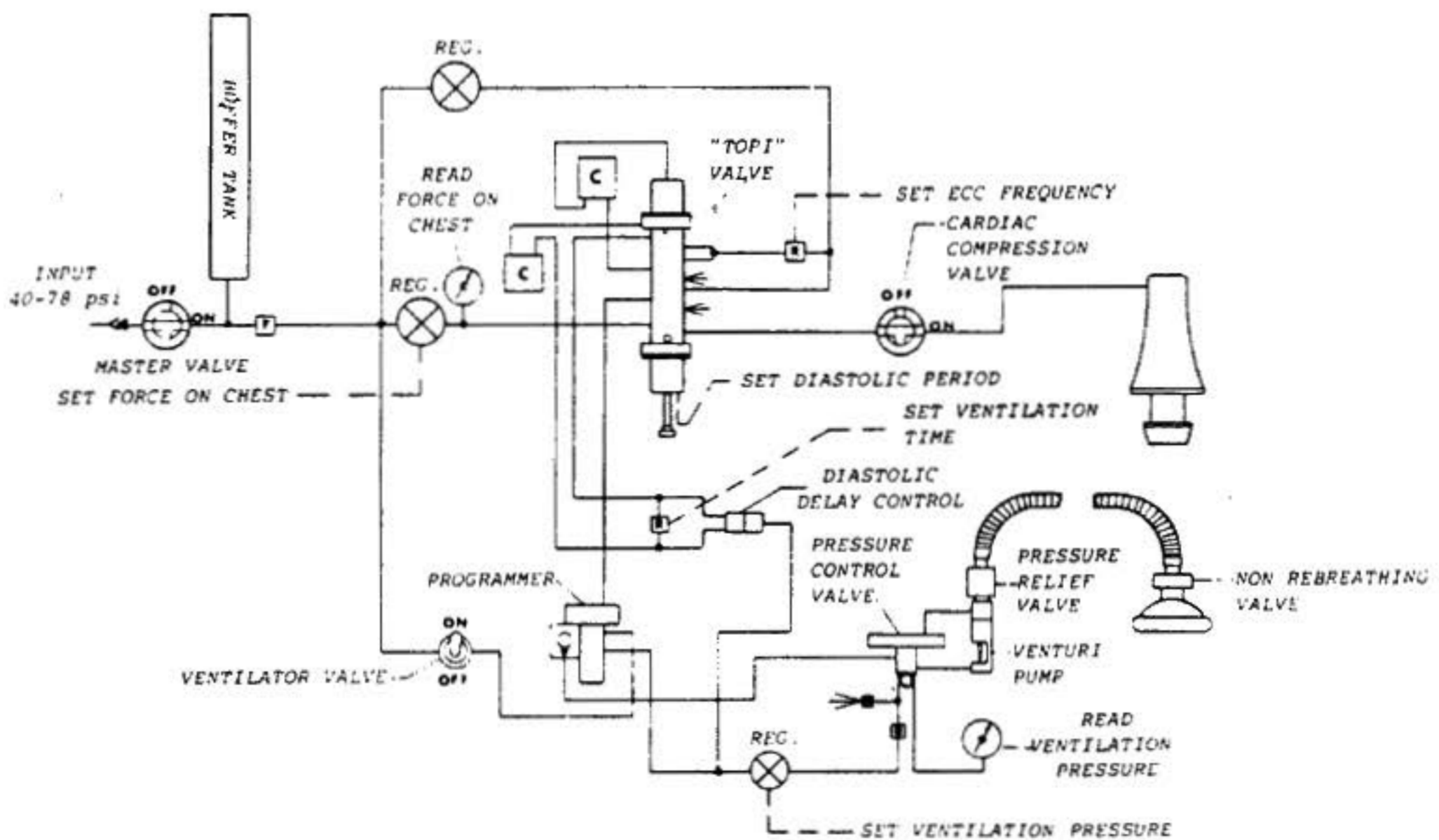

Figure 6A-18



Functional Schematic Of The MII Simultaneous Compression-Ventilation Heart-Lung Resuscitator

Figure 6A-19

NOTE: If the patient is intubated, increased airway resistance imposed by the endotracheal tube may require a higher maximum airway pressure in order to achieve adequate chest rise. With the proper installation of a cuffed endotracheal tube, limiting ventilation pressure may be increased as needed, up to 60 cm of H₂O.

NOTE: After an hour of CPR, it is likely that the patient's chest will become flattened from the sternal compressions. In order to maintain adequate compression depth, it will be necessary to lower the plunger further, by remeasuring with steps 8-12 above.

CAUTION: At least one operator must continue to monitor the operation of the HLR and the responses of the patient at all times while the unit is in use.

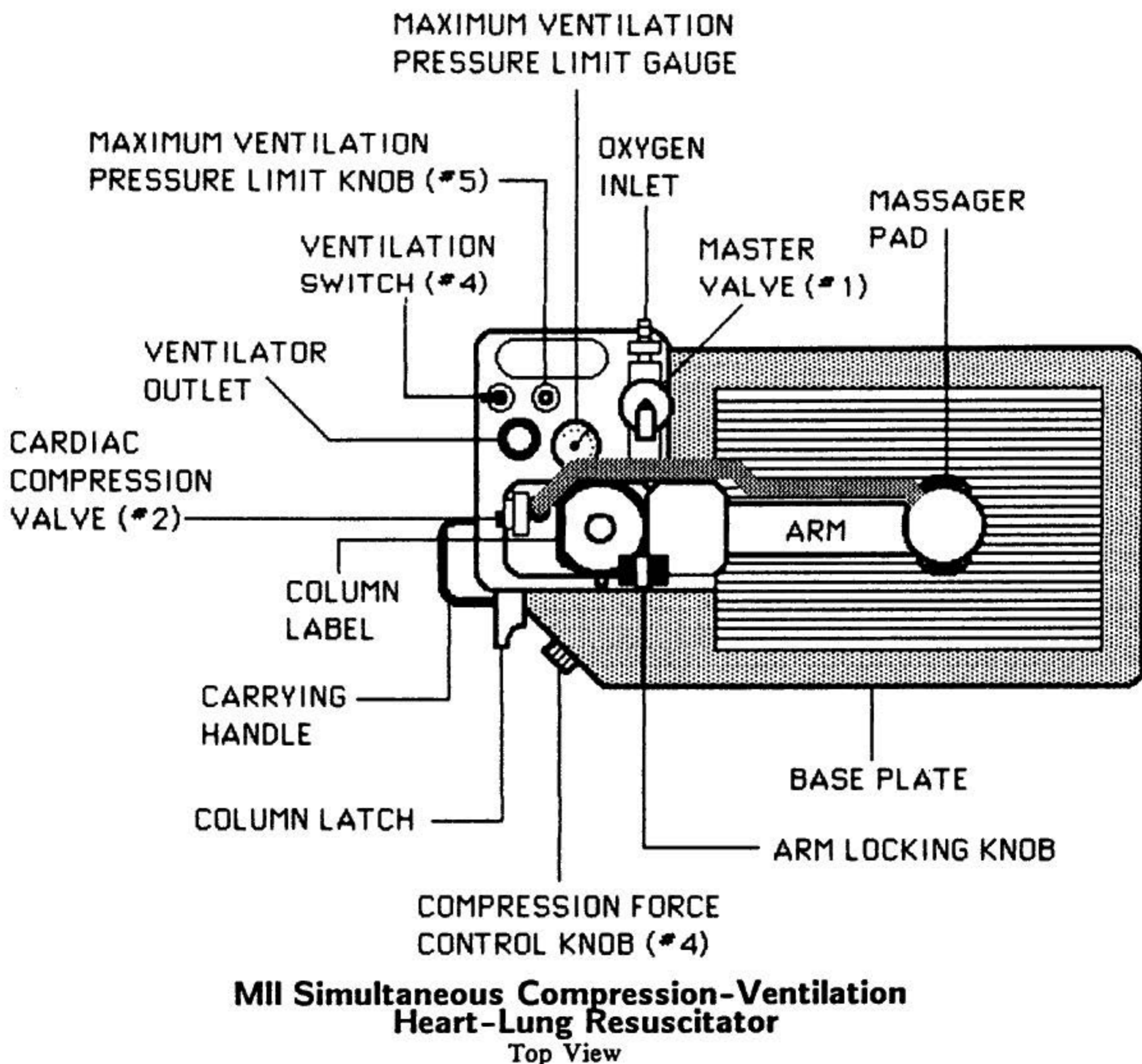

Figure 6A-20

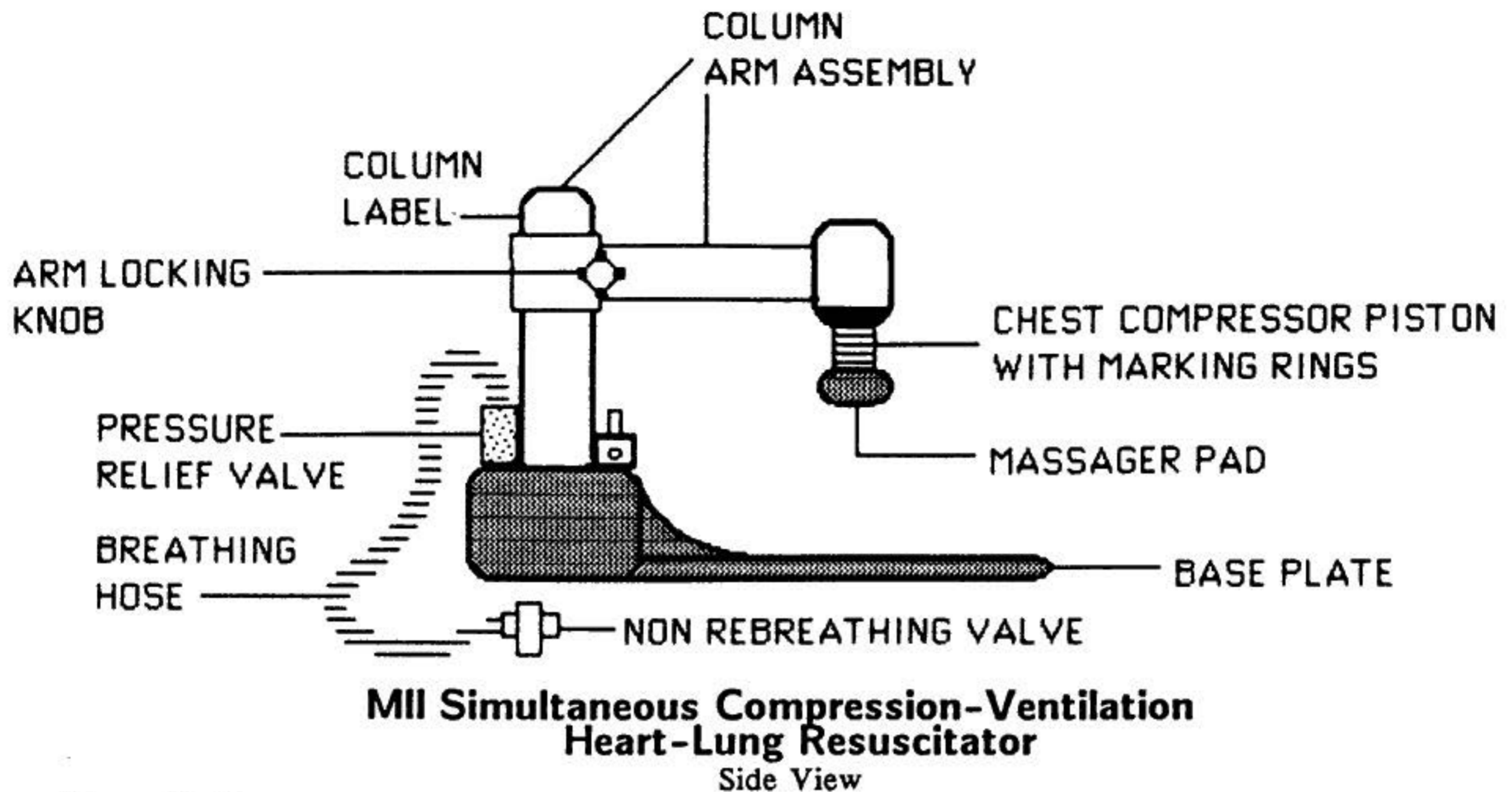

Figure 6A-21

Simultaneous Compression-Ventilation CPR Unit (MII "Life Aid" Resuscitator)

1) During an interruption in CPR of no longer than five seconds, elevate the patient's head and shoulders (or roll the patient onto his side) and slip the **Thumper Board** of the device under the patient with the patient's head extending over the hump at the top of the **Thumper Board** (if the **Thumper Board** has not already been positioned under the patient prior to the start of manual CPR). This extends the head and facilitates opening of the airway and positioning of the patient for intubation, if it has not been carried out already. Manual cardiac compression and ventilation are then resumed. If the **Thumper Board** is not available, place the base plate of the machine under the patient at the start of manual CPR.

2) Insert the MII-HLR **Base Plate** into the **Thumper Board**. To accomplish this, insert the tip of the **Base Plate** into the flared opening between the two plastic sheets and push it into place until a positive stop is felt (the patient need not be moved or lifted to accomplish this). (Figure 6A-22.)

3) Remove the **Arm/Column Assembly** from the storage case. Holding the column as shown in Figure 6A-23 (with the **Cardiac Compression Valve (#2)** toward the rescuer), loosen the **Arm Locking Knob** and swing the arm 90° on the column towards the patient's feet, then tighten the **Arm Locking Knob** slightly.

4) Attach the **Arm/Column Assembly** to the base plate of the HLR, as shown in Figure 6A-24. Accomplish this by tipping the column slightly forward, slipping the "toe" of the column base into its slot, then pulling the column back sharply until it is latched.



Figure 6A-22



Figure 6A-23



Figure 6A-24

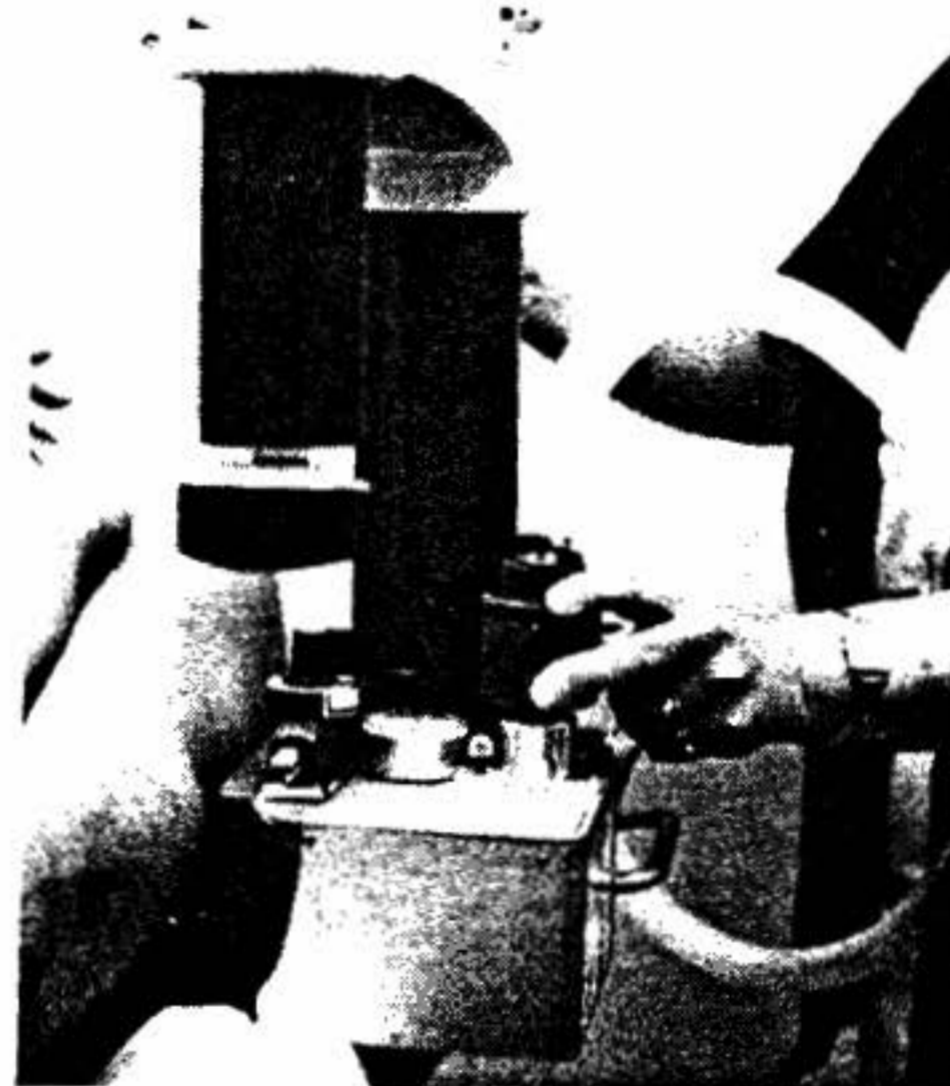

Figure 6A-25

5) Connect the Pressure Relief Valve (large green fitting) on the end of the Breathing Hose to the Ventilator Outlet per *Figure 6A-25*.

6) Verify that the Master Valve (#1) is in its "OFF" position, that the Cardiac Compression Valve (#2) is "OFF", that the Ventilation Switch (#4) is "OFF", and that the Compression Force Control Knob (#3) is off (fully counterclockwise). Then connect the inlet end of the Oxygen Input Hose to a 50 to 90 psi oxygen source (If the source has a valve, turn it on) and the black end (outlet) of the Oxygen Input Hose to the inlet adjacent to the Master Valve (#1) (*Figure 6A-26*).



Figure 6A-26



Figure 6A-27

NOTE: Connection to the oxygen source must be done first. The hose is normally with the E-cylinder Portable Oxygen Pack; if it is being used, the hose should be left connected.

7) Grasp the Piston just above the Massager Pad and raise the Piston up into its cylinder until the bottom marking ring in the piston is just about to disappear into the cylinder. With the left hand, support the Arm and hold the Massager Pad in place. With right hand, loosen the Arm Locking Clamp.

CAUTION: Wipe the patient's chest dry of any perspiration, electrode paste, antiseptics, melted ice/water, or any other material present which might contaminate the shaft of the Chest Compressor Piston. It is critical that the piston not become wetted or contaminated with foreign material, as it may seize-up and cause the HLR to stop operating. Particular care must be taken when transporting the patient to avoid wetting the piston with water from the PIB.



Figure 6A-28

8) During the next manual ventilation cycle, quickly swing the Arm over the patient's chest, while lowering it at the same time (*Figure 6A-27*). Take care to keep the bottom marking ring just visible. Position the Massager Pad on the lower half of the patient's sternum, and with the massager's long axis parallel to the sternum. The massager pad must not extend beyond the bottom of the patient's sternum (*Figure 6A-28*). (*Not* over the patient's xiphoid process.) Lock arm in place.

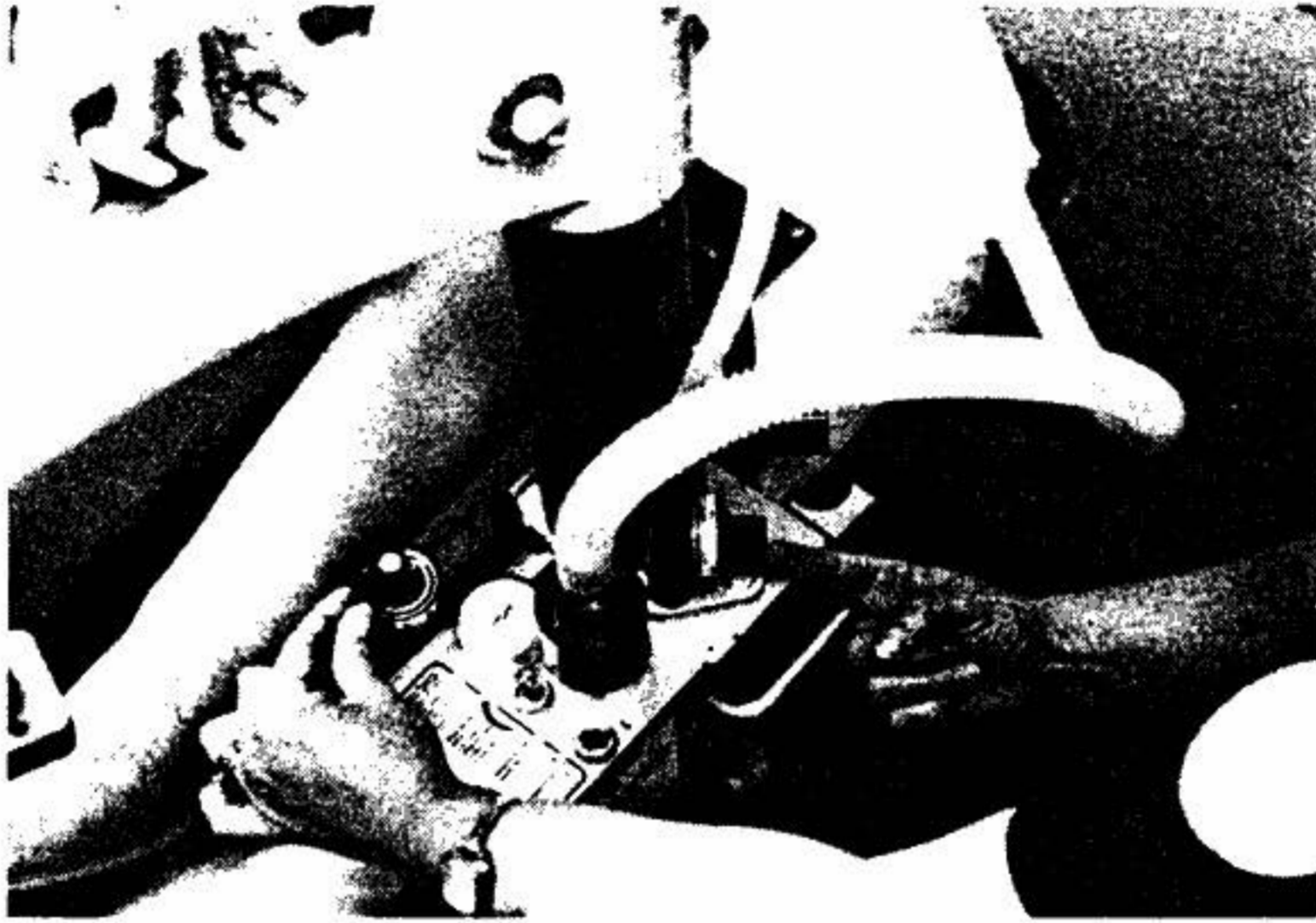
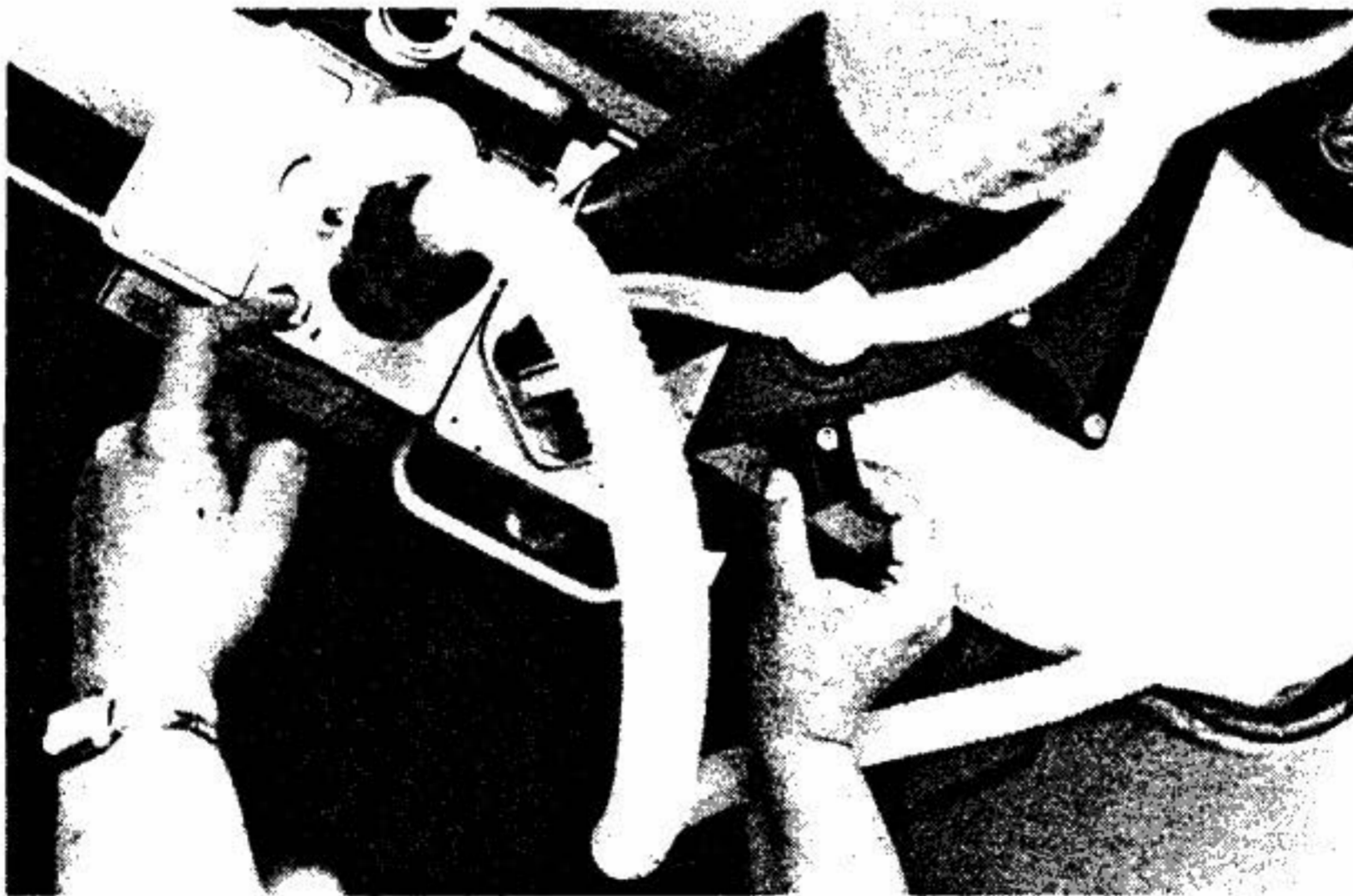

Figure 6A-29

Figure 6A-30



9) Turn the Master Valve (#1) "ON", and confirm that the force on the Compressor Force Gauge is zero; then turn the Cardiac Compression Valve (#2) to "ON" (Figure 6A-31).

The ventilator will begin to cycle with *each compression* once the Master Valve is turned on.

10) *Adult Setting*: Gradually turn the Compression Force Control Knob (#3) (Figure 6A-30) clockwise until the piston depresses the sternum 20-25% of the chest A-P diameter. With full-grown adults, displacement should be approximately 1½" to 2". In general, this will occur when the Compressor Force Gauge ("Force On Chest") indicates 60 to 80 pounds of force.

Since displacement is the proper criterion for setting the force, Marking Rings on the Piston are provided to facilitate this adjustment. The wide rings are 1½" apart; the displacement of an adult chest should be approximately the space between two of these wide rings. Additional rings are provided at ½" intervals to aid in establishing incrementally smaller or greater degrees of compression.

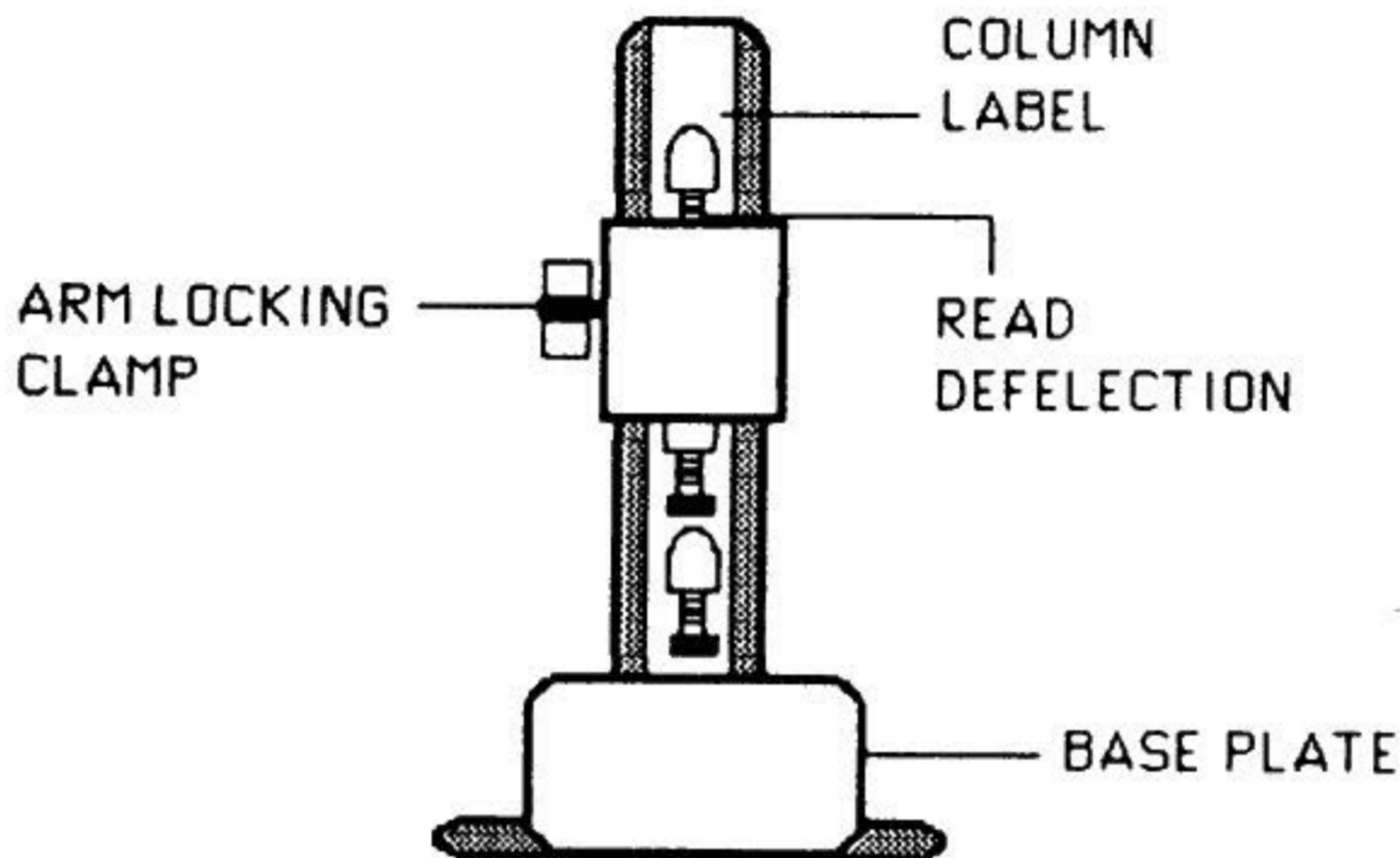

Figure 6A-31

NOTE: Some later units have a Column Label and color coded Marking Rings on the Piston which can be used to determine the correct chest deflection. The procedure for use of this feature is as follows:

a) Allow the arm of the HLR to slide down the column until the bottom Marking Ring on the Piston is just emerging from the cylinder which houses the Piston.

b) Increase Compressor Force Control until the piston matches the lowest complete picture on the column above the arm clamp (Figure 6A-31).

Steps 7 through 10 should be repeatedly practiced so that the total time required to set chest compressor deflection does not result in more than a five second interruption in CPR.

11) At the same time as steps 8-10, the Technician in charge of respirations should attach the End-Tidal CO₂ Detector above the endotracheal tube or EGTA.

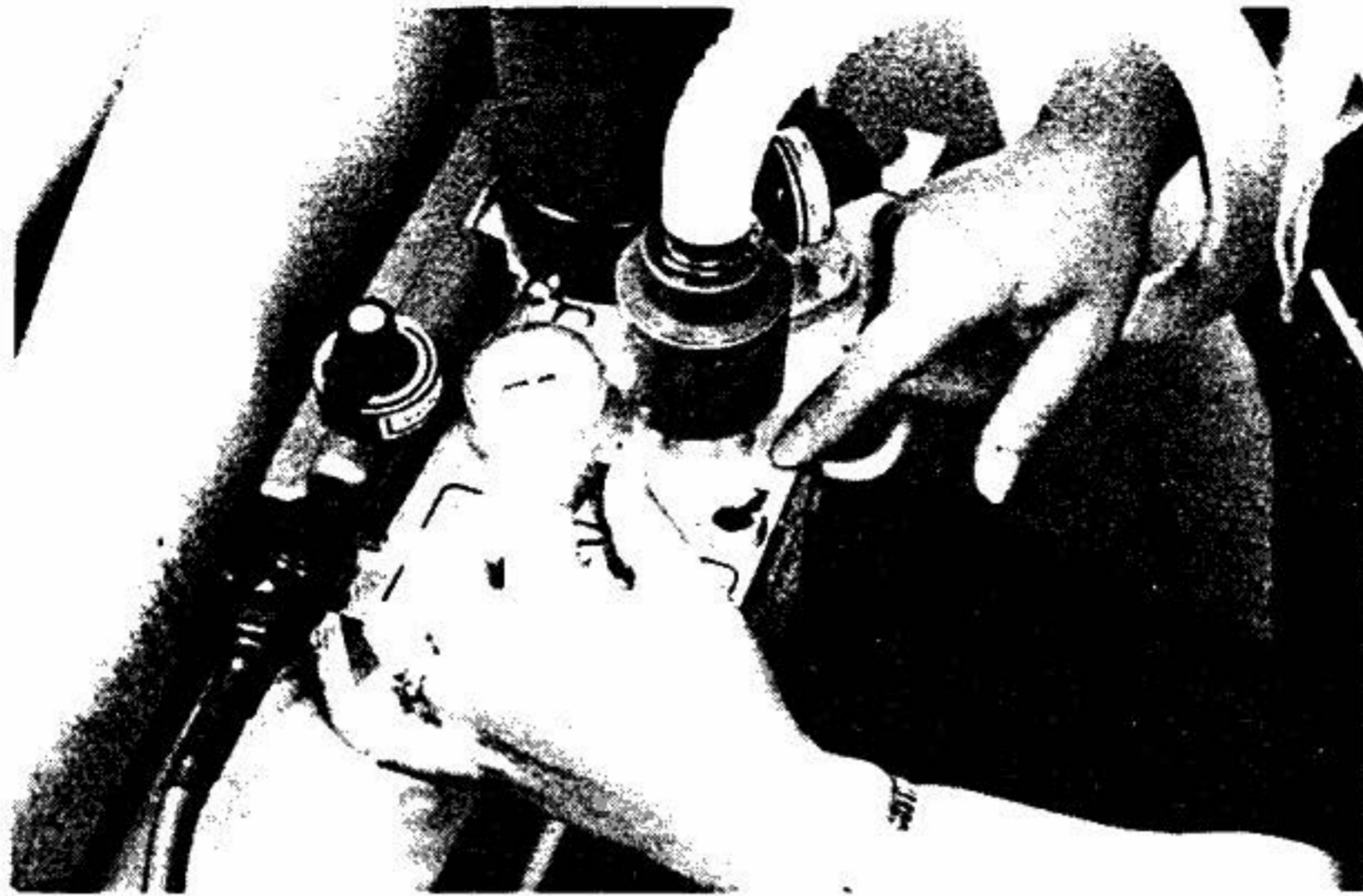

Figure 6A-32

12) Verify that the maximum ventilation setting is at the normal pre-setting of 60 cm of H₂O. This maximum pressure limit setting is read continuously on the Ventilation Pressure Gauge once the Master Valve is turned on. If incorrect, it can be adjusted by rotating the Ventilation Pressure Control Knob (#5) (clockwise to increase, counterclockwise to reduce). When the ventilator pressure has been so set, attach the end of the breathing hose to the endotracheal tube or EGTA and turn the Ventilation Switch (#4) to the "ON" position (Figure 6A-32).

13) Carotid arterial pulse should be evaluated and be determined to be present with each chest compression. End tidal CO₂ concentration should be no less than 3%. (If it is below 3%, something is seriously wrong. See Chapter 5, **Cardiopulmonary Support: Evaluation And Intervention**, especially page 5-5, for possible corrective actions.)

14) The Transport Technician should continue to monitor the unit for proper equipment function and proper settings, and monitor the patient for palpable pulse, adequate chest rise during ventilation, and adequate end-tidal CO₂. If the pulse is weak or undetectable, sternal deflection can be increased by lowering the column height. If cardiac output is still deemed to be inadequate, the maximum ventilation pressure limit should be increased by turning the Ventilation Pressure Control Knob (#5) clockwise to increase the limit pressure to 95 cm H₂O (the unmarked upper limit of the red zone on the gauge).

NOTE: After an hour of CPR, it is likely that the patient's chest will become flattened from the sternal compressions. In order to maintain adequate compression depth, it will be necessary to lower the plunger further, by remeasuring with steps 7-10 above.

CAUTION: At least one operator must continue to monitor the operation of the HLR and the responses of the patient at all times while the unit is in use.

Application Of The MII-HLRs With the PIB

The procedure for application of the MII-HLRs using the PIB differs from the preceding protocols in the following ways (this presumes the PIB is already assembled):

1. Have the **Backboard** in place before the patient is put into the PIB.
- 2) Slide the **Base Plate** into the cutout provided in the side of the **Portable Ice Bath** (also before the patient is put into the bath, if possible.)
- 3) Attach the **Column Arm** to the **Base Plate** of the MII-HLR per the preceding instructions.
- 4) Loosen the **Arm Locking Clamp** and swing the Arm 90° away from the baseplate.
- 5) Position the MII-HLR in the PIB frame underneath the tank so that the **Piston** will not be too far up on the patient's chest when he is placed in the PIB.
- 6) Connect the **Breathing Hose** and the **Oxygen Supply Hose** per instructions above.
- 7) Interrupt manual CPR and lift/lower the patient into the PIB. The patient will probably have to be positioned as close to the Head of the PIB as possible.
- 8) Grasp the **Piston** just above the **Massager Pad** and raise it up into its cylinder. Holding it there, loosen the **Arm Locking Clamp** and swing the arm over towards the patient's chest, while lowering it at the same time.

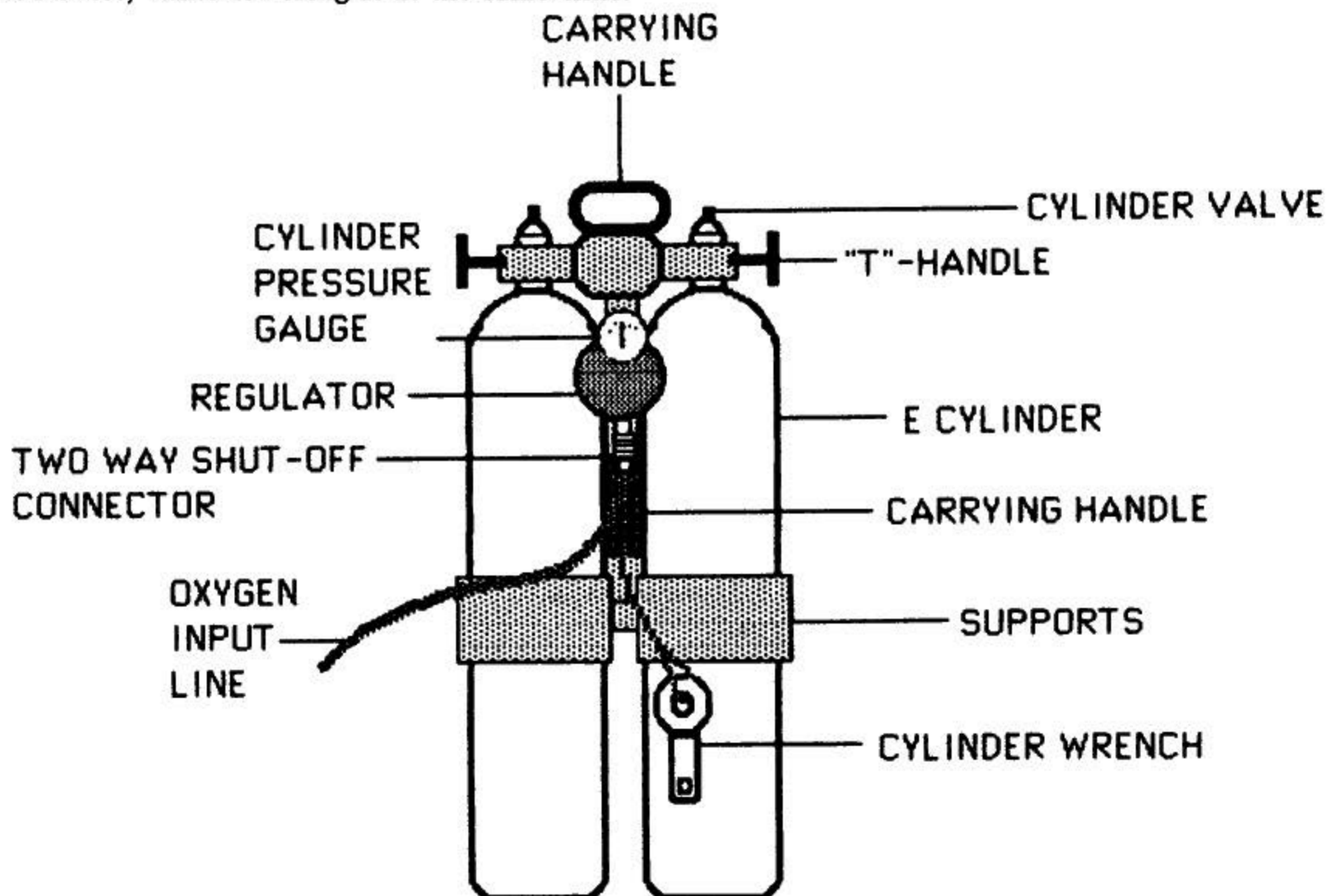

Portable Oxygen Pack

Figure 6A-33

Follow the rest of the appropriate protocol (above) to install the MII-HLR and begin mechanical CPR.

9) If possible, start external cooling of the patient by packing him in crushed ice at the same time that application of the HLR is being undertaken. Be sure not to place any ice in the PIB *before* placing the patient in it, as this will make proper application of the HLR impossible.

10) Stow the **Portable Oxygen Pack** on the PIB and transfer any IV bottles to the PIB IV pole.

The patient can now be transported from the home, hospital, or nursing home.

Input Oxygen Pressure

When used with the portable **Oxygen Pack** containing two E-cylinders, the oxygen pressure delivered to the unit is preset at 90 psi. When using an alternate oxygen source, such as hospital wall oxygen or a larger oxygen cylinder and regulator, the input pressure must be in the 50 to 90 psi range. This pressure assures delivery of up to 95 cm H₂O pressure during ventilation and at least 125 pounds of compressor thrust. If the pressure in the tanks falls below 40 psi, the maximum compressor thrust may decrease to below 100 pounds per compression and may result in inadequate sternal excursion in larger individuals. If the pressure drops further, the compression rate will decrease and the unit will eventually fail to cycle. Thus, it is imperative that a minimum input pressure of at least 40 psi be maintained at the oxygen source for effective, uninterrupted resuscitation.

NOTE: The High Impulse HLR is very sensitive to the oxygen input pressure. A higher "specific impulse" and thus more efficient CPR can be achieved by operating the unit at the high end of the 50-90 psi range (i.e., at 90 psi).

CAUTION: Do not connect the HLR to any oxygen source with a pressure greater than 110 psi, or the unit may be seriously damaged and promptly rendered inoperative.

Portable Oxygen Pack

The **Portable Oxygen Pack** is designed to hold two "E" sized oxygen cylinders, each of which contains approximately 570 liters of oxygen (at 1 atm., 70°F). In typical adult use, this will power the HLR for about 30 minutes (perhaps as much as 10 MINUTES LESS for the SCV-CPR unit). The **Portable Oxygen Pack** features a pre-set and locked regulator which reduces the E-cylinder pressure from 2300 psi and delivers it to the **Oxygen Input Line** at 90 psi, ±5%. A check valve is included in each cylinder circuit, making it possible to remove and replace an empty cylinder while using oxygen from another cylinder.

Quick "in-and-out" cylinder exchange can be carried out with the **Portable Oxygen Pack** in either the horizontal or vertical position.

Additional cylinder sealing washers are stored in the middle orange drawer of the **Emergency Medications Kit (Gray Box)**.

CAUTION: While oxygen is itself a non-flammable gas, it can greatly accelerate the rate of combustion or the likelihood of ignition of other materials. Dramatically increased rates of burning and burning of materials not normally thought of as being

flammable can occur (i.e., brass and aluminum regulators may burn!). Never use oil or lubricants of any kind on oxygen regulators, yokes, or any fittings or parts that will be used for oxygen service! Never use oxygen around open flames or sparks.

The **Portable Oxygen Pack** is for short-term use, to move the patient from one source of oxygen to another, as when the patient is moved from the hospital or nursing home to an ambulance. The **Portable Oxygen Pack's** gas supply should be conserved as much as possible, and should be used only when other sources of oxygen (wall outlet or larger "H" or "G" cylinders) are not available.

Operation

1) Start gas flow to the **Regulator** by opening one or both of the oxygen **Cylinder Valves**, using the **Cylinder Wrench** provided.

2) Check cylinder pressure for each cylinder on the **Pressure Gauge** of the **Portable Oxygen Pack** (it should read 2,000 to 2,300 psi). If the cylinder pressure is 500 psi or less, open the second cylinder and read the pressure. If it is less than the pressure of the first cylinder, the indicated pressure will not change.

*NOTE: Only one cylinder should be used at a time, since the design of the **Portable Oxygen Pack** guarantees that both cylinders will run out simultaneously if they are both open. Generally, the cylinder with the lower pressure should be used first, and then the second cylinder opened, and the first cylinder closed and replaced with a fresh cylinder ASAP (see following section). In any event, the oxygen pack pressure should be monitored regularly.*

3) Connect the **Oxygen Input Hose** to the **Oxygen Inlet** on the HLR.

Cylinder Replacement

When the **Cylinder Pressure Gauge** reads less than 200 psi, the cylinder should be shut off and exchanged for a full cylinder. This may be accomplished while oxygen is being used from the opposite cylinder. To accomplish this:

1) Using the **Cylinder Wrench** turn the valve of the cylinder to be changed completely off (rotate clockwise viewed from valve end of the cylinder to the end of its travel).

2) Unscrew the **T-Handle** counterclockwise a minimum of six full turns.

3) Pull the top of the cylinder towards the **T-Handle** to free it from the locating pins.

4) Slide the cylinder out of the yoke assembly.

5) Place a new cylinder in the yoke. After insuring that the washer seal is in place and the locating pins are engaged, tighten the **T-Handle** on the yoke by rotating it clockwise as far as hand tightening will permit. (If the seal leaks, or the operator is not strong enough, the wrench may be used in a kludge fashion to further tighten the T-handle. Before this is done, however, the cylinder should be shut off again, the T-handle loosened, and the seal examined.)